

LT2216 CMA2

Spare parts

Ersatzteile

Pièces détachées

Reserve onderdelen

Repuestos

Reservdelar



ILLUSTRATED PARTS LIST

MFG. ID NO. 96061028300

CUSTOMER CATALOG NO. LT2216CMA2

PRODUCT NO. 960 61 02-83

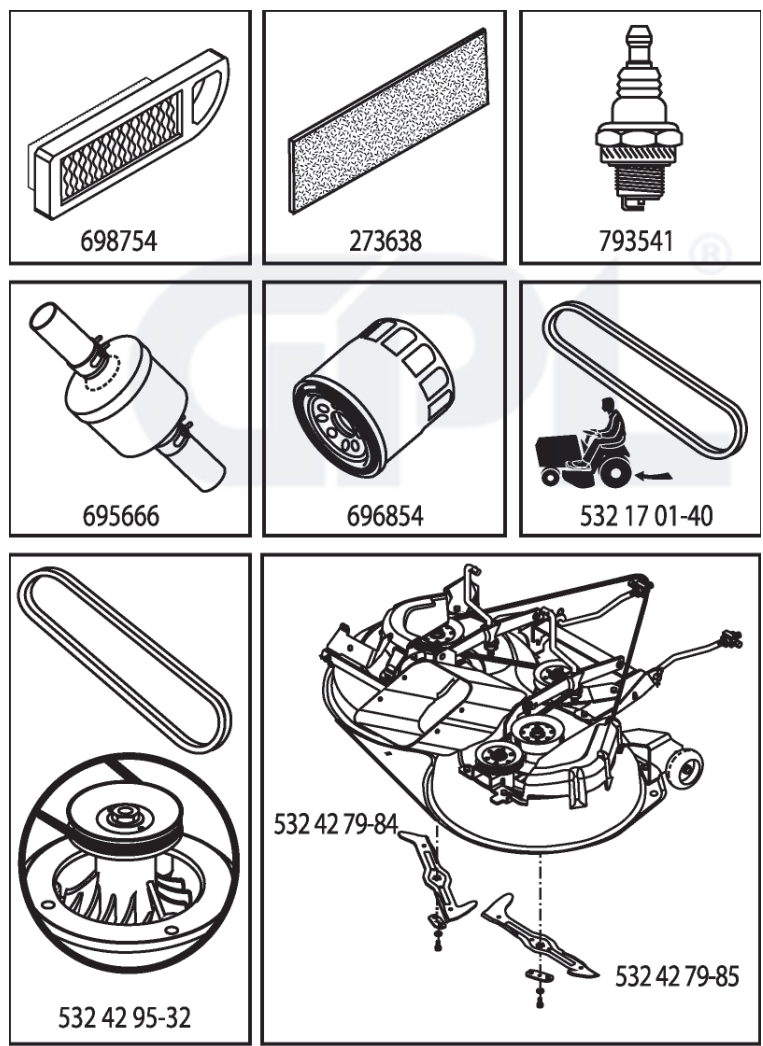

47

433150

**TRACTOR - - MODEL NO. LT2216CMA2 (96061028300), PRODUCT NO. 960 61 02-83
DECALS 27**

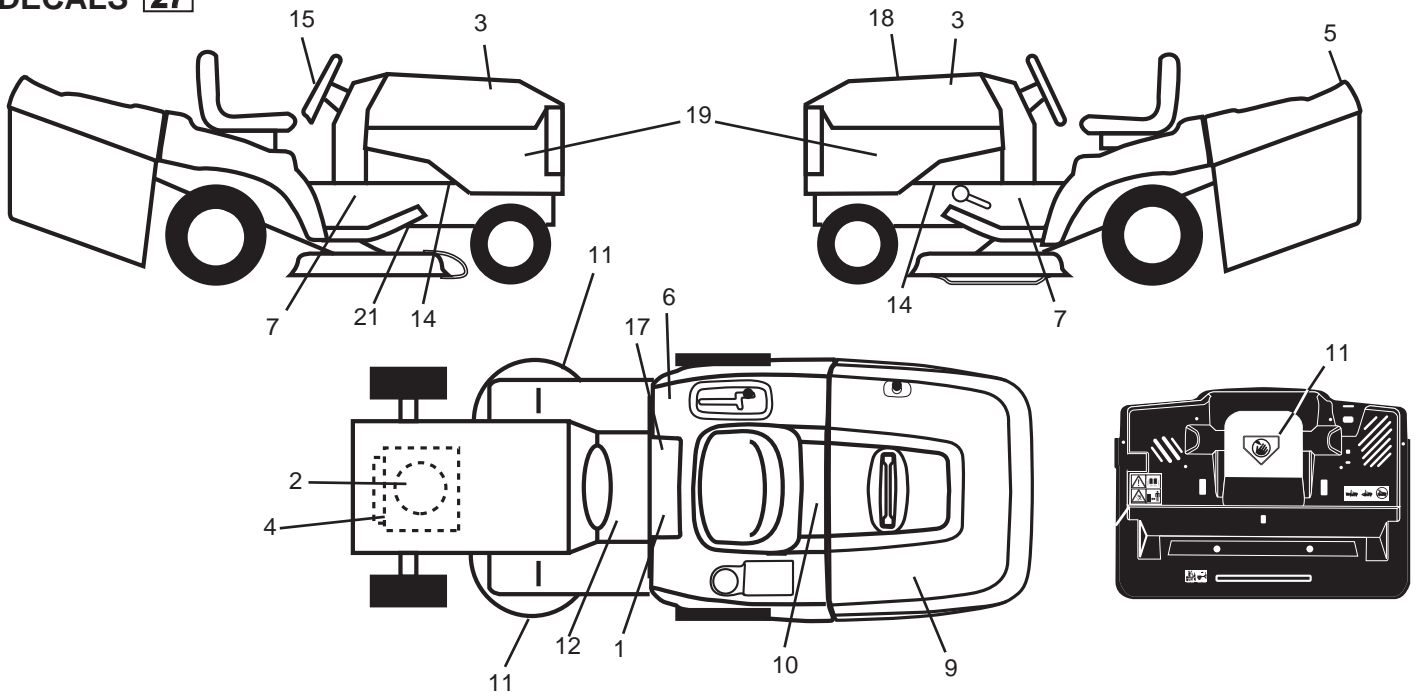

KEY NO.	PART NO.	DESCRIPTION
1	532 40 03-89	Decal, Warning Syms. CE
2	532 41 65-31	Decal, Hp Engine
3	532 42 28-49	Decal, Hood RH/LH
4	532 19 68-41	Decal, Warning Eng. Syms.
5	532 18 39-30	Decal, Fndr
6	532 18 04-32	Decal, 100 DBA/CE
7	532 40 11-46	Decal, Decal Warning Service/Fire
9	532 18 39-31	Decal, Cover/Belt
10	532 14 50-05	Decal, Bat Dan/Poi P/L Sym Wpn
11	532 18 21-66	Decal, Mower Cut Finger CE
12	532 15 97-37	Decal, Brake/Clutch Symbol Lt

KEY NO.	PART NO.	DESCRIPTION
14	532 15 97-36	Decal, Chassis Hot Muffler
15	532 42 26-85	Decal, Steering Wheel
17	532 14 08-37	Decal, Saddle Brake Parking
18	532 43 31-50	Decal, Hood RPL
19	532 42 29-95	Decal, Side Panel
21	532 16 62-86	Decal, Hex Belt Sch 92 CRD
--	532 16 69-60	Decal Bypass
--	532 18 10-91	Pad Footrest LH
--	532 18 10-90	Pad Footrest RH
--	532 43 32-00	Manual Operator's (Euro)

WHEELS & TIRES

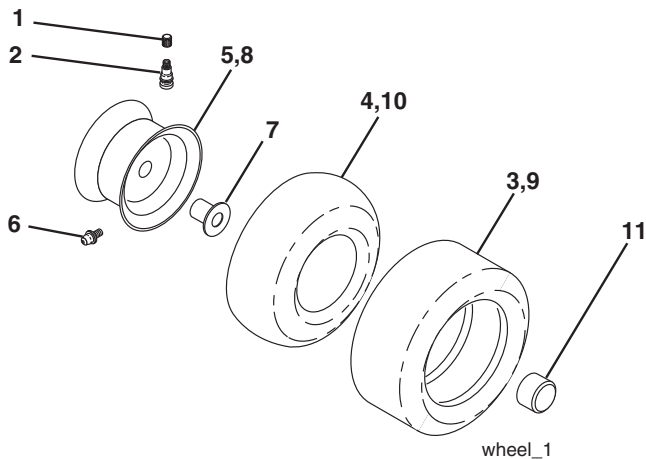

KEY NO.	PART NO.	DESCRIPTION
1	532 05 91-92	Cap Valve Tire
2	532 06 51-39	Stem Valve
3	532 10 62-22	Tire F Ts 15 x 6 0 - 6 Service
4	532 05 99-04	Tube Inner Front #35060
5	532 13 83-36	Rim Asm 6" Front Service
6	532 12 49-57	Fitting Grease
7	532 12 49-59	Bearing Flange
8	532 13 83-37	Rim Asm 8" Rear Service
9	532 12 20-82	Tire R Ts 20 x 10-8 C.Service
10	532 12 49-26	Tube Rear 9 5 x 8 Service
11	532 17 50-39	Cap Axle Blk 1 50 x 1 00
--	532 14 43-34	Sealant, Tire (10 oz. tube)

NOTE: All component dimensions given in U.S. inches
1 inch = 25.4 mm

TRACTOR - - MODEL NO. LT2216CMA2 (96061028300), PRODUCT NO. 960 61 02-83 SCHEMATIC 38

SCH07

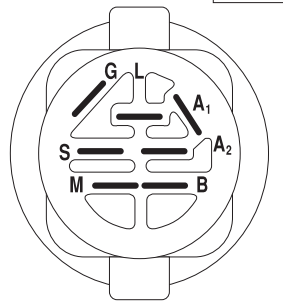
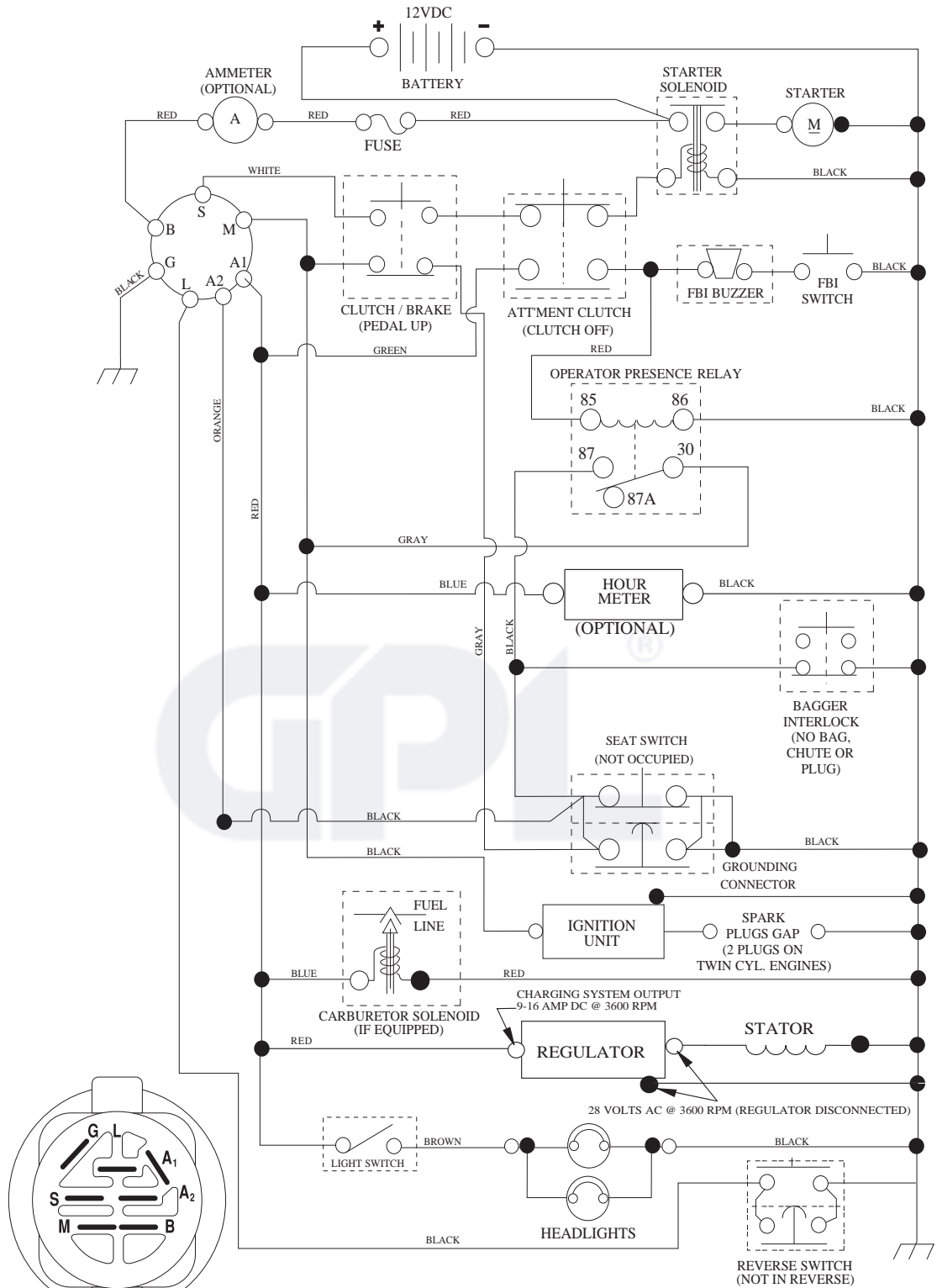

IGNITION SWITCH

POSITION	CIRCUIT	"MAKE"
OFF	M+G+A1	
RUN/OVERRIDE	B+A1	
RUN	B+A1	L+A2
START	B + S + A1	

WIRING INSULATED CLIPS
NOTE: IF WIRING INSULATED CLIPS WERE REMOVED FOR SERVICING OF UNIT, THEY SHOULD BE RE-INSTALLED TO PROPERLY SECURE YOUR WIRING.

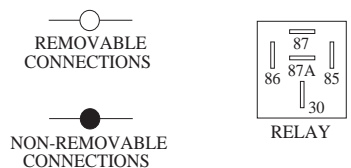

TRACTOR - - MODEL NO. LT2216CMA2 (96061028300), PRODUCT NO. 960 61 02-83
 ELECTRICAL **32**

C04

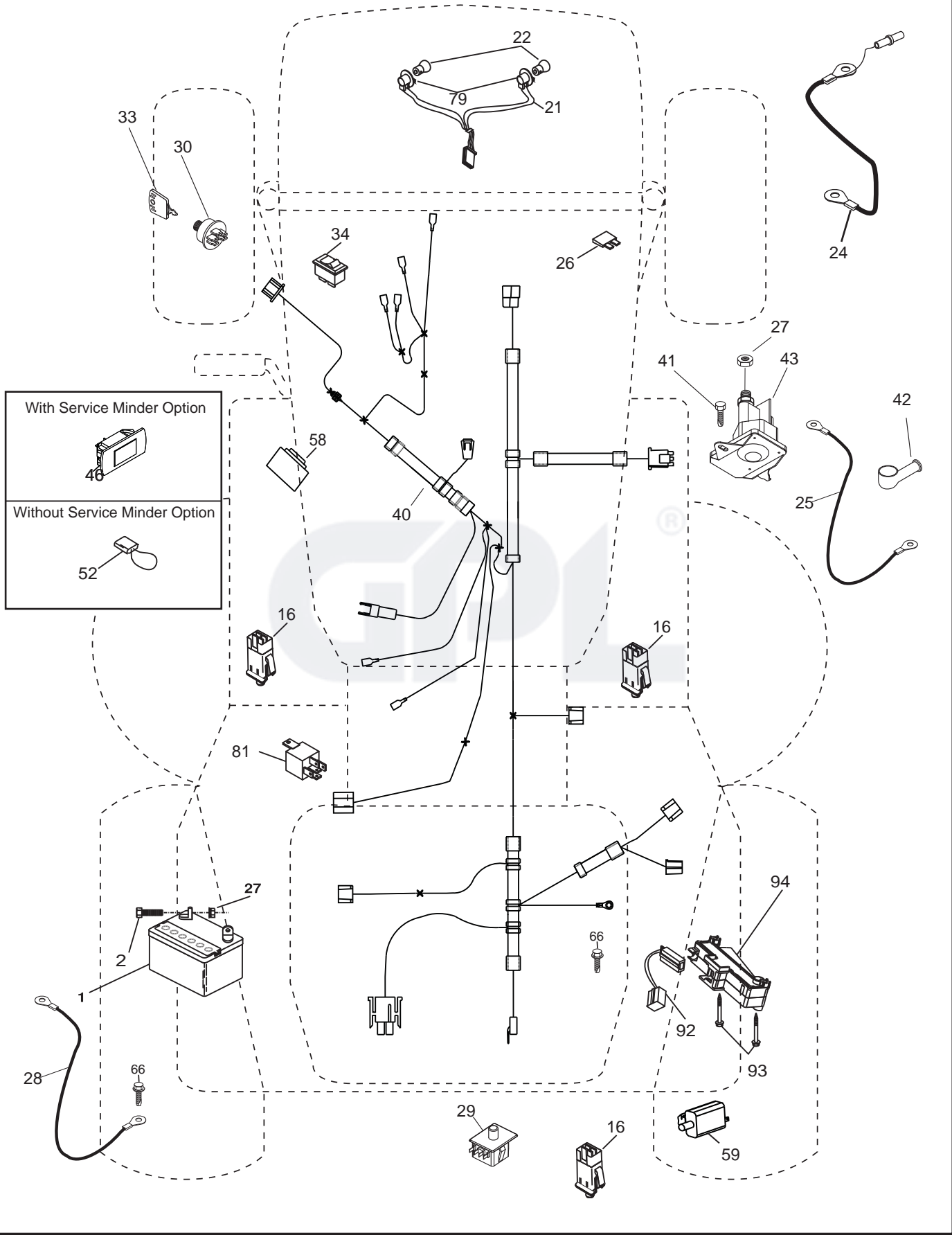

**TRACTOR - - MODEL NO. LT2216CMA2 (96061028300), PRODUCT NO. 960 61 02-83
ELECTRICAL 32**

KEY NO.	PART NO.	DESCRIPTION
1	532 16 34-65	Battery
2	874 76 04-12	Bolt Hex Hd 1/4-20 unc x 3/4
16	532 17 61-38	Switch Interlock
21	532 18 37-59	Harness Asm Light w/4152J
22	532 00 41-52	Bulb Light #1156
24	532 16 59-87	Cable Battery CRD 56" Red
25	532 42 12-99	Cable Starter
26	532 17 51-58	Fuse
27	873 51 04-00	Nut Keps Hex 1/4-20 unc
28	532 12 77-25	Cable Ground 6 Ga. 18" Black
29	532 19 27-49	Switch Seat
30	532 19 33-50	Switch Ignition
33	532 41 19-35	Key/Chain
34	532 11 07-12	Switch Light
40	532 40 36-20	Harness Ignition
41	871 11 04-08	Bolt Flk Fin Hex 1/4-20 unc x 1/2
42	532 13 15-63	Cover Terminal Red
43	532 19 25-07	Solenoid
46	532 40 17-63	Gauge SRV HRMTR [®]
58	532 16 94-19	Buzzer CRD
59	532 18 03-79	Switch FBI CRD
66	817 49 06-08	Screw Thdrol 3/8-16 x 1/2 Ty-Tt
79	532 17 52-42	Socket Asm. Bulb Twistlock
81	532 10 97-48	Relay Asm
92	532 19 66-15	Harness Pigtail
93	532 19 25-40	Screw Plastite 10-14 x 2.0
94	532 19 18-34	Module Reverse

NOTE: All component dimensions given in U.S. inches.
1 inch = 25.4 mm.

TRACTOR - - MODEL NO. LT2216CMA2 (96061028300), PRODUCT NO. 960 61 02-83
CHASSIS AND ENCLOSURES **39**

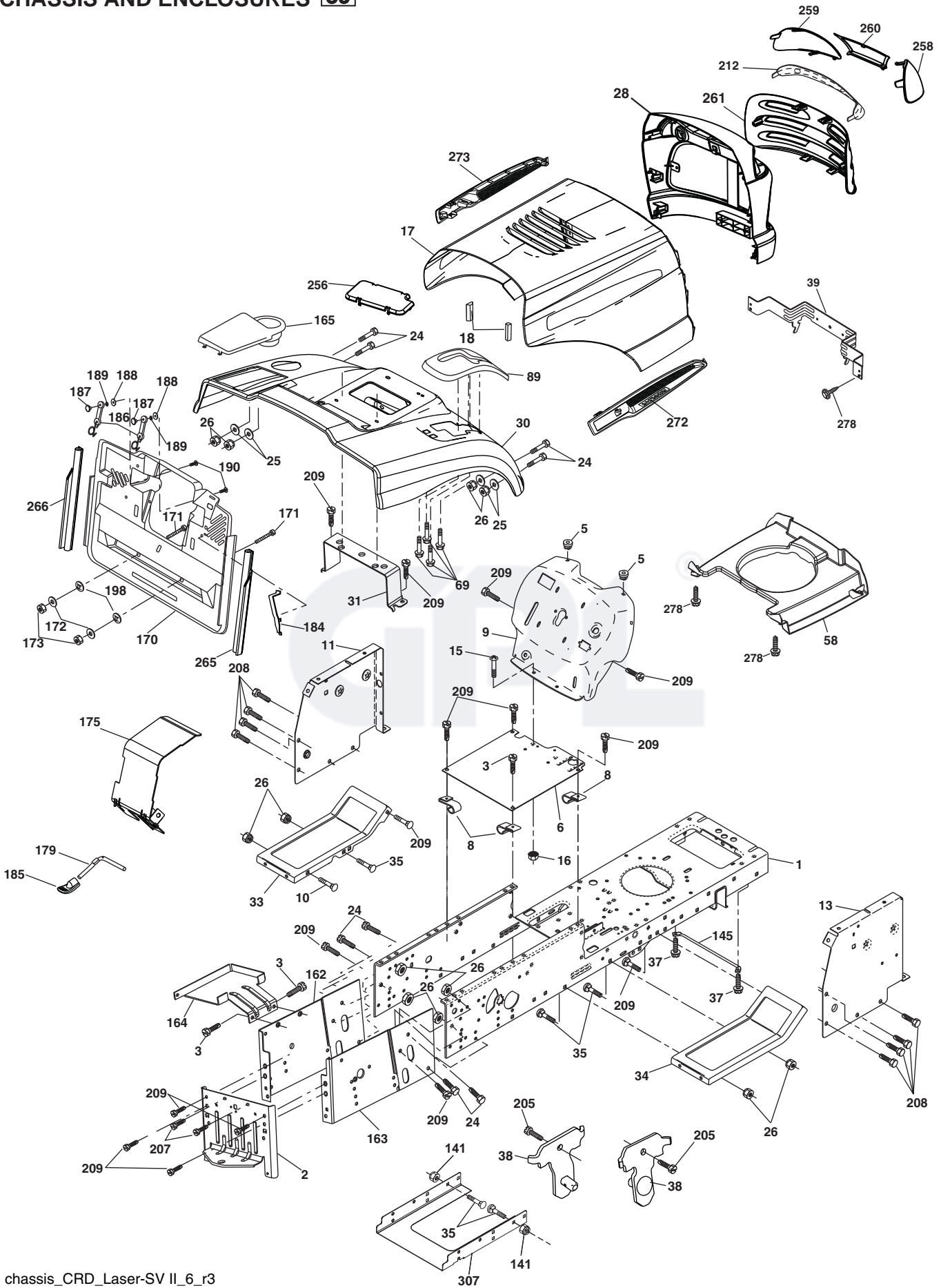

**TRACTOR - - MODEL NO. LT2216CMA2 (96061028300), PRODUCT NO. 960 61 02-83
CHASSIS AND ENCLOSURES **39****

KEY NO.	PART NO.	DESCRIPTION	KEY NO.	PART NO.	DESCRIPTION
1	532 17 46-20	Chassis	165	532 18 13-56	Cover Battery
2	532 18 03-84	Drawbar	170	532 19 94-88	Backplate Asm CRD
3	817 06 06-12	Screw 3/8-16 x 3/4	171	872 14 06-20	Bolt Rdhd Sqnk 3/8-16 x 2-1/2 Gr. 5
5	532 15 52-72	Bumper Hood/Dash	172	819 13 20-16	Washer 13/32 x 1-1/4 x 16 Ga.
6	532 18 44-19	Saddle	173	873 51 06-00	Nut, Keps Hex 3/8-16 unc
8	532 12 64-71	Clip Insulator 13/32 Mtg. Hole	175	532 18 82-03	Guard Trap
9	532 40 51-33	Dash	179	532 18 82-02	Rod Pivot FBI CRD
10	872 14 06-08	Bolt, Carriage 3/8-16 x 3/4	184	532 17 46-62	Bracket Actuator Bagger CRD
11	532 17 49-96	Panel, Dash, LH	185	532 18 11-01	Knob Rod Brake Parking
13	532 17 21-06	Panel, Asm. Dash RH	186	532 16 07-93	Latch Asm Mulch/Bagger
15	874 18 05-12	Screw, Machine, Truss Head 5/16-18 unc x 3/4	187	532 12 50-04	Nut Weld
16	873 51 05-00	Nut	188	819 06 12-16	Washer #10
17	532 42 43-21	Hood	189	810 07 10-00	Washer Lock #10
18	532 18 49-21	Bumper Hood	190	871 08 10-10	Screw Pan Hd Phillip 10-24 x 5/8
24	874 78 06-16	Bolt	198	532 16 89-37	Nut, Push
25	819 13 13-12	Washer 13/32 x 13/16 x 12 Ga.	205	817 49 06-08	Screw Thdrol 3/8-16 x 1/2
26	873 80 06-00	Nut	207	817 67 05-08	Screw 5/16-18 x 1/2
28	532 42 68-19	Grille	208	817 67 06-08	Screw Thdrol 3/8-16 x 1/2
30	532 19 73-44	Fender	209	817 00 06-12	Screw Hex Wsh Thdrol 3/8-16
31	532 16 51-56	Bracket, Fender Support	212	532 18 42-48	Insert Lens
33	532 18 11-93	Footrest, LH	256	532 18 13-61	Cover Fender
34	532 18 11-94	Footrest, RH	258	532 19 05-07	Lens Grille RH
35	872 11 06-06	Bolt	259	532 19 05-08	Lens Grille LH
37	817 49 05-08	Screw Thdrol 5/16-18 x 1/2 TYT	260	532 40 83-82	Cover Lens
38	532 18 17-48	Bracket Asm Pivot Mower Rear	261	532 42 43-24	Insert Grille
39	532 40 78-07	Bracket Pivot	265	532 18 57-04	Seal RH Side Bagger
58	532 18 45-38	Duct Intake Air	266	532 18 57-03	Seal LH Side Bagger
69	532 14 24-32	Screw Hex 1/4-1/2 unc	272	532 42 52-00	Vent Side RH
89	532 19 73-66	Console	273	532 42 51-98	Vent Side LH
141	873 90 06-00	Nut	278	532 41 63-58	Screw #10 x 0.750 BOS Thread
145	532 40 91-67	Rod Pivot Chassis/Hood	307	532 42 51-25	Shield Chassis Front
162	532 18 03-82	Bracket Exten Chassis LH CRD			
163	532 18 03-83	Bracket Exten Chassis RH CRD			
164	532 16 56-05	Support Battery CRD			

NOTE: All component dimensions given in U.S. inches.
1 inch = 25.4 mm.

**TRACTOR - - MODEL NO. LT2216CMA2 (96061028300), PRODUCT NO. 960 61 02-83
DRIVE 40**

KEY NO.	PART NO.	DESCRIPTION	KEY NO.	PART NO.	DESCRIPTION
1	-----	Transaxle Hydro Gear 321-0510	120	873 90 06-00	Nut Lock Flg. 3/8-16 unc
8	532 19 27-06	Rod, Shift Fender Adjust Lt	150	532 16 58-50	Bushing, Bellcrank Grnd Dr
9	532 40 85-79	Clutch Asm Noram	151	819 13 32-10	Washer 13/32 x 2 x 10 Ga.
10	876 02 04-16	Pin, Cotter 1/8 x 1	156	532 16 60-02	Washer Srrted 5/16 ID x 1.125
14	810 04 04-00	Washer, Lock Hvy Helical	158	532 16 55-89	Bracket Shift Mount
15	874 49 05-44	Bolt Hex FGHD 5/16-18 x Gr 5	159	532 18 39-00	Hub Shift
16	873 80 05-00	Nut Lock Hex w/Ins 5/16-18 unc	161	872 14 04-06	Bolt Rdhd Sqnk 1/4-20 x 3/4 Gr. 5
19	873 80 06-00	Nut Lock Hex w/Ins 3/8-16 unc	162	873 68 04-00	Nut Crownlock 1/4-20 unc
21	532 13 05-64	Knob	163	874 78 04-16	Bolt Hex Fin 1/4-20 unc x 1 Gr. 5
22	532 17 56-07	Rod Brake, Main	165	532 16 56-23	Bracket Pivot Lever
24	873 35 06-00	Nut Hex Jam 3/8-16 unc	166	817 49 05-10	Screw 5/16-18 x 5/8
25	532 19 20-36	Spring, Rod, Brake	167	532 16 55-88	Bracket Support Shift CRD
27	876 02 04-12	Pin, Cotter 1/8 x 3/4	168	532 16 54-92	Bolt Shoulder 5/16-18 x .561
28	532 17 57-65	Rod, Parking Brake	169	532 16 55-80	Plate Fastening Lt
29	532 07 16-73	Cap, Parking Brake	171	817 49 06-08	Screw Thdrol 3/8-16 x 1/2 Ty-Tt
30	532 16 95-92	Bracket, MTG-20" Transaxle	172	532 17 02-71	Shaft Asm Shifter Frt CRD
34	532 17 55-78	Shaft, Asm Pedal Foot CRD	177	532 16 59-32	Keeper Flat Idler 3.06" CRD
35	532 12 01-83	Bearing, Nylon	181	532 18 02-11	Bracket Idler Ground Drive CRD
36	819 21 16-16	Washer 21/32 x 1 x 16 Ga.	182	532 18 26-82	Keeper Belt 2.5" Od V-Idler CRD
37	532 12 49-63	Pin, Roll 3/16 x 1"	183	532 19 95-34	Pulley V-Idler CRD
38	532 16 59-36	Pulley Flat Composite 3.06"	185	532 17 00-08	Link Shift
39	874 76 06-44	Bolt Fin Hex 3/8-16 unc x 2-3/4	186	532 16 56-14	Hub Tapered Round CRD
40	532 12 49-65	Spacer, Split 395 x 59 Bzp	187	817 58 05-20	Screw Thdrol 5/16-18 x 1.25
42	819 13 13-12	Washer 13/32 x 13/16 x 12 Ga.	197	532 16 96-13	Nyliner Snap-In 5/8
43	819 11 10-12	Washer 11/32 x 5/8 x 12 Ga.	199	532 16 96-12	Bolt Shoulder 5/16-18 unc
47	532 12 77-83	Pulley, Idler, V Groove Plastic	200	872 14 05-08	Bolt RDHD SQNK 5/16-18 x 1
48	532 15 44-07	Bellcrank Clutch Grnd Drv	203	871 17 07-80	Bolt Hex 7/16-20 x 5
49	532 12 32-05	Retainer, Belt Style Spring	207	532 16 98-45	Washer Nylon Rear
50	872 11 06-12	Bolt Carr. Sh. 3/8-16 x 1-1/2 Gr. 5	214	532 17 56-09	Shaft Asm. Brake
51	873 68 06-00	Nut, Crownlock 3/8-16 unc	215	532 17 56-52	Rod Brake Hydro
52	873 68 05-00	Nut Crownlock 5/16-18	252	819 13 16-16	Washer 13/32 x 1 x 16 Ga.
53	532 19 96-52	Link, Clutch 7.66	253	532 17 50-28	Bracket Cable Chassis
55	532 10 57-09	Spring, Return, Clutch	254	817 00 06-16	Screw 3/8-16 x 1
56	817 06 06-20	Screw 3/8-16 x 1-1/4	255	532 17 56-08	Brace Shaft Brake Mtg.
57	532 17 01-40	V-Belt Kev 112" 0650 CRD	258	532 17 80-62	Clip Retainer
62	532 12 48-72	Cover, Pedal	259	532 18 02-12	Bracket Pulley
65	810 04 07-00	Washer, Lock 7/16	261	532 13 14-94	Pulley Idler
66	532 15 47-78	Keeper, Belt Engine F-Proof	262	872 11 06-22	Bolt Carr. 3/8-16 x 2-3/4 Gr. 5
71	532 16 91-83	Strap, Torque, LH	263	817 00 06-12	Screw 3/8-16 x 3/4
73	532 16 91-82	Strap, Torque, RH	264	532 43 11-74	Bracket Idler Chassis
74	532 13 70-57	Spacer, Split	265	532 40 46-07	Spacer
75	532 12 17-49	Washer 25/32 x 1-1/4 x 16 Ga.	266	532 18 20-61	Shield Idler Mower
76	812 00 00-01	Ring, E	292	532 40 02-71	Spacer Noram
77	532 12 35-83	Key, Square	293	872 14 06-28	Bolt 3/8-16 x 3-1/2
78	532 12 17-48	Washer 25/32 x 1-5/8 x 16 Ga.	294	532 19 70-33	Nut Jam 3/8-16
81	532 17 00-06	Asm, Shaft, Cross Rear	295	532 17 91-14	Pulley Idler Composite
82	532 16 57-11	Spring, Torsion	297	817 49 06-10	Screw 3/8-16 x 5/8
83	819 17 12-16	Washer 17/32 x 3/4 x 16 Ga.			
84	532 17 00-07	Link, Transaxle			
95	532 17 00-15	Control Asm Bypass Hydro, Rod			
96	532 12 47-88	Spring, Retainer 1"			
112	819 09 12-10	Washer 9/32 x 3/4 x 10 Ga.			

NOTE: All component dimensions given in U.S. inches
1 inch = 25.4 mm

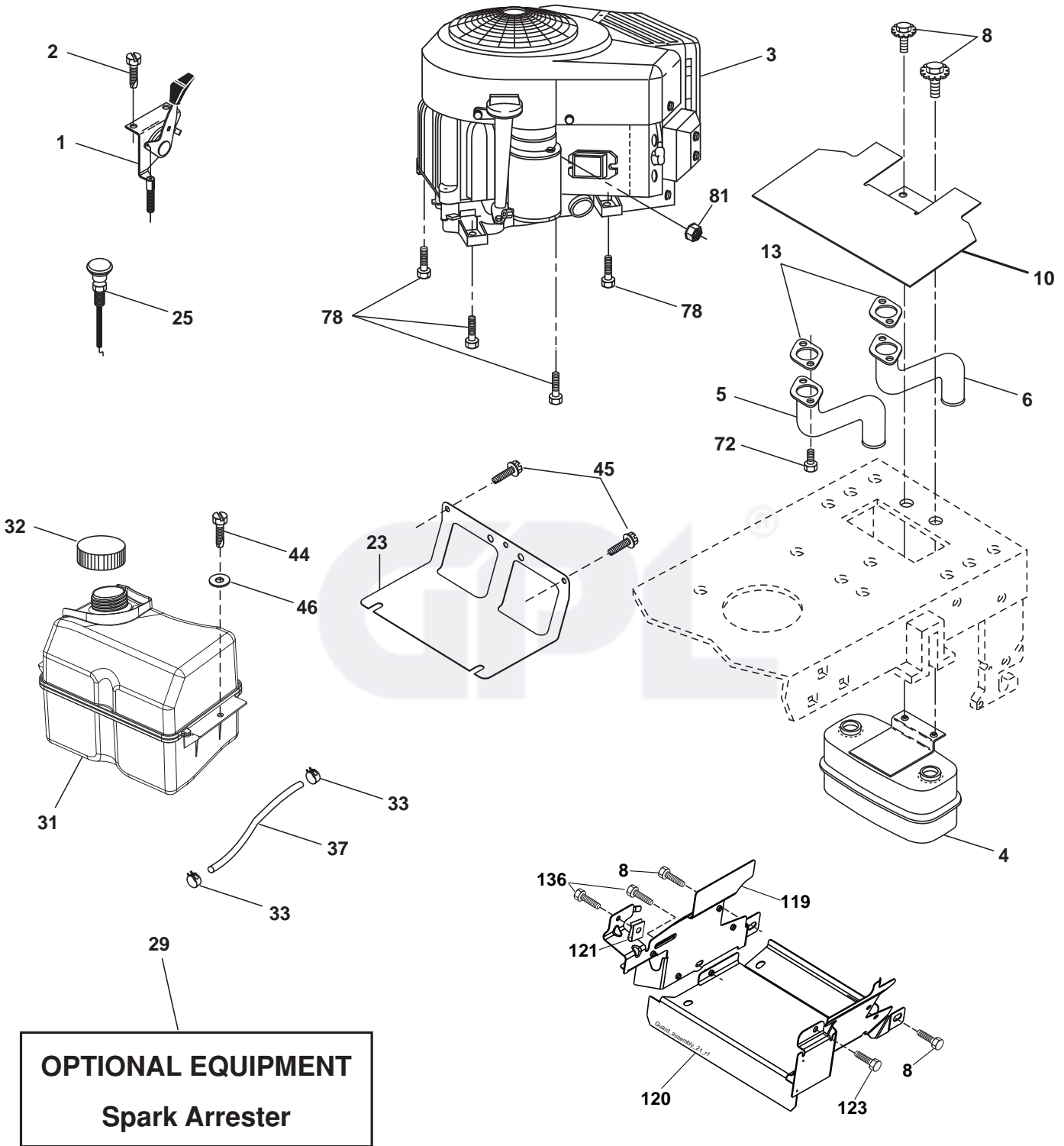

engine-CRD_bs_13

**TRACTOR - - MODEL NO. LT2216CMA2 (96061028300), PRODUCT NO. 960 61 02-83
ENGINE 24**

KEY NO.	PART NO.	DESCRIPTION
1	532 17 07-71	Control Throt/Ch
2	817 72 04-08	Screw 1/4-20 x 1/2
3	-----	Engine B&S Model 401577-1219-B1
4	532 14 97-23	Muffler Exhaust B&S LT
5	532 16 05-89	Exhaust Tube RH
6	532 15 99-55	Exhaust Tube LH
8	532 17 18-77	Bolt 5/16-18 unc x 3/4
10	532 14 66-29	Shield Heat Muffler
13	532 16 53-91	Gasket Muffler
23	532 16 98-37	Shield Browning/Debris Guard
25	532 19 18-12	Control Choke
29	532 13 71-80	Arrester Spark
31	532 40 75-51	Tank Fuel
32	532 43 02-20	Cap Asm Fuel
33	532 12 34-87	Clamp Hose Blk
37	532 13 70-40	Line Fuel 20"
44	817 67 04-12	Screw Hexwsh Thdrol 3/8-16 x 1
45	817 00 06-12	Screw 3/8-16 x 3/4
46	819 09 14-16	Washer 9/32 x 7/8 x 16 Ga.
72	532 18 39-06	Screw Socket Head 5/16-18 x 1
78	817 06 06-20	Screw 3/8-16 x 1-1/4
81	873 51 04-00	Nut Keps Hex 1/4-20 unc
119	532 19 97-68	Guard Asm. Eng. LH
120	532 19 97-67	Guard Asm. Eng. RH
121	532 19 66-88	Clips Threaded
123	817 67 05-08	Screw Thdrol 5/16-18 x 1/2
136	532 13 77-29	Screw Thd Roll 1/4-20 x 5/8

NOTE: All component dimensions given in U.S. inches
1 inch = 25.4 mm

Engine Power Rating Information

The gross power rating for individual gas engine models is labeled in accordance with SAE (Society of Automotive Engineers) code J1940 (Small Engine Power & Torque Rating Procedure), and rating performance has been obtained and corrected in accordance with SAE J1995 (Revision 2002-05). Torque values are derived at 3060 RPM; horsepower values are derived at 3600 RPM. Actual gross engine power will be lower and is affected by, among other things, ambient operating conditions and engine-to-engine variability. Given both the wide array of products on which engines are placed and the variety of environmental issues applicable to operating the equipment, the gas engine will not develop the rated gross power when used in a given piece of power equipment (actual "on-site" or net power). This difference is due to a variety of factors including, but not limited to, accessories (air cleaner, exhaust, charging, cooling, carburetor, fuel pump, etc.), application limitations, ambient operating conditions (temperature, humidity, altitude), and engine-to-engine variability. Due to manufacturing and capacity limitations, Briggs & Stratton may substitute an engine of higher rated power for this Series engine.

TRACTOR - - MODEL NO. LT2216CMA2 (96061028300), PRODUCT NO. 960 61 02-83
 STEERING ASSEMBLY **41**

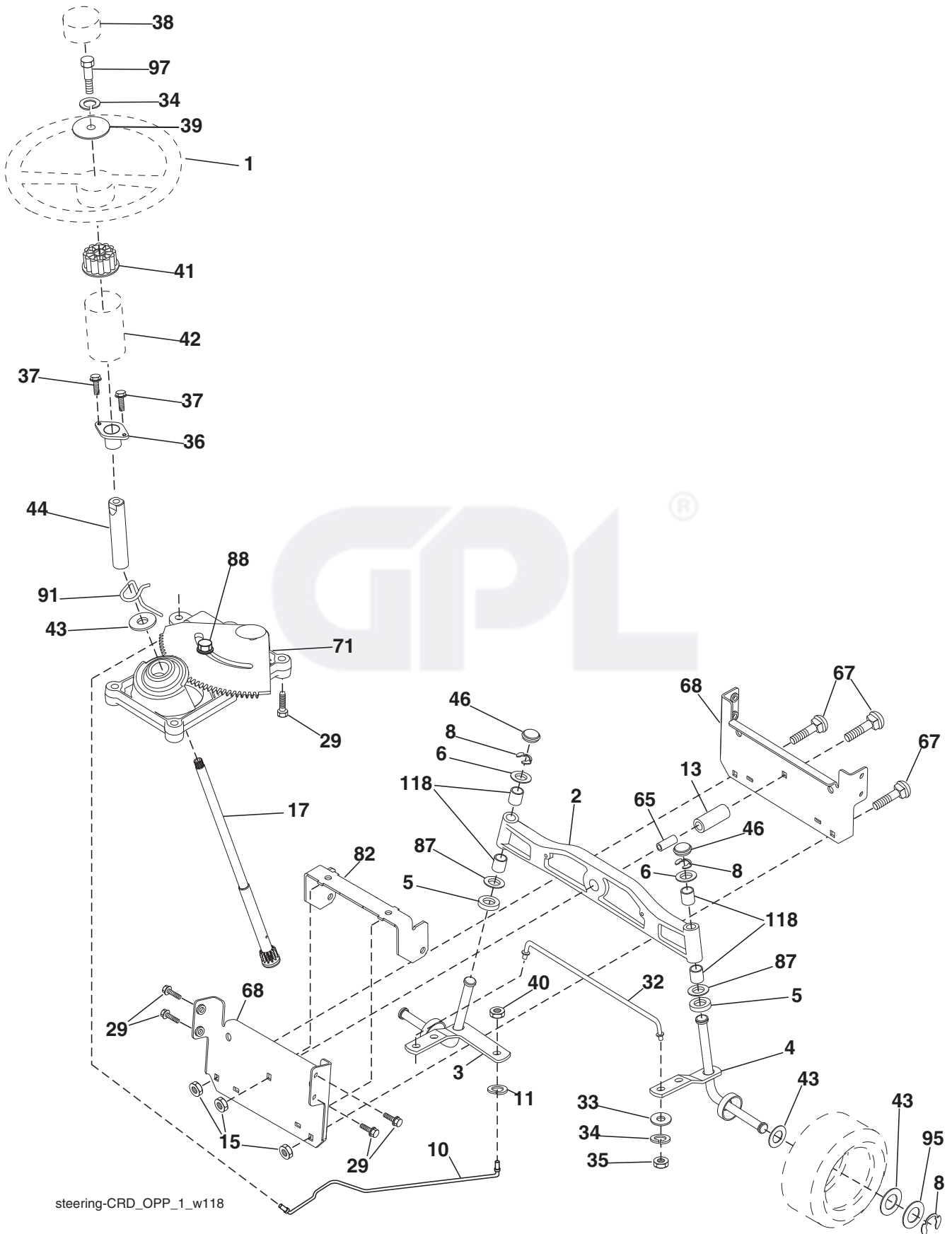

steering-CRD_OPP_1_w118

**TRACTOR - - MODEL NO. LT2216CMA2 (96061028300), PRODUCT NO. 960 61 02-83
STEERING ASSEMBLY **41****

KEY NO.	PART NO.	DESCRIPTION
1	532 42 41-46	Steering Wheel
2	532 19 35-42	Front Axle Assembly
3	532 16 98-40	Spindle Assembly, LH
4	532 16 98-39	Spindle Assembly, RH
5	532 12 49-31	Bearing, Race, Thrust, Hardened
6	532 12 17-48	Washer 25/32 x 1-5/8 x 16 Ga.
8	812 00 00-29	Ring, Clip
10	532 17 51-21	Link, Drag
11	810 04 06-00	Washer, Lock
13	532 13 65-18	Spacer Axle
15	532 14 52-12	Nut Hex Flange Lock
17	532 19 07-53	Shaft Assembly, Steering
29	817 00 06-12	Screw 3/8-16 x 3/4
32	532 17 01-62	Rod, Tie
33	819 11 12-16	Washer 11/32 x 3/4 x 16 Ga.
34	810 04 05-00	Washer Lock Hvy Hlcl Spr 5/16
35	873 54 05-00	Crownlock Nut 5/16-24 unc
36	532 15 50-99	Bushing, Steering
37	532 15 29-27	Screw TT #10-32 x 5 x 3/8 Flange
38	532 42 41-47	Cap Wheel Steering
39	819 11 38-12	Washer 11/32 ID x 2 3/8 OD x 12 Ga.
40	873 54 06-00	Nut Crownlock 3/8-24 unf
41	532 18 67-37	Adaptor, Steering Wheel
42	532 16 96-33	Boot, Steering
43	532 12 17-49	Washer 25/32 x 1-1/4 x 16 Ga.
44	532 19 07-52	Extension Steering
46	532 12 12-32	Cap, Spindle
65	532 41 47-36	Spacer Axle
67	872 11 06-18	Bolt Rdhd Sq 3/8-16 x 2-1/4
68	532 16 98-27	Brace Axle
71	532 17 51-46	Steering Asm.
82	532 19 99-78	Bracket Susp. Chassis Front
87	532 17 39-66	Washer Flat .781 x 1-1/2 x .14
88	532 17 51-18	Bolt Shoulder 7/16-20 unc
91	532 17 55-53	Clip Steering
95	532 18 89-67	Washer
97	532 42 89-82	Bolt 5/16-18 x 4 w/Patch
118	532 40 60-13	Bushing

NOTE: All component dimensions given in U.S. inches.
1 inch = 25.4 mm.

TRACTOR - - MODEL NO. LT2216CMA2 (96061028300), PRODUCT NO. 960 61 02-83
 MOWER DECK **44**

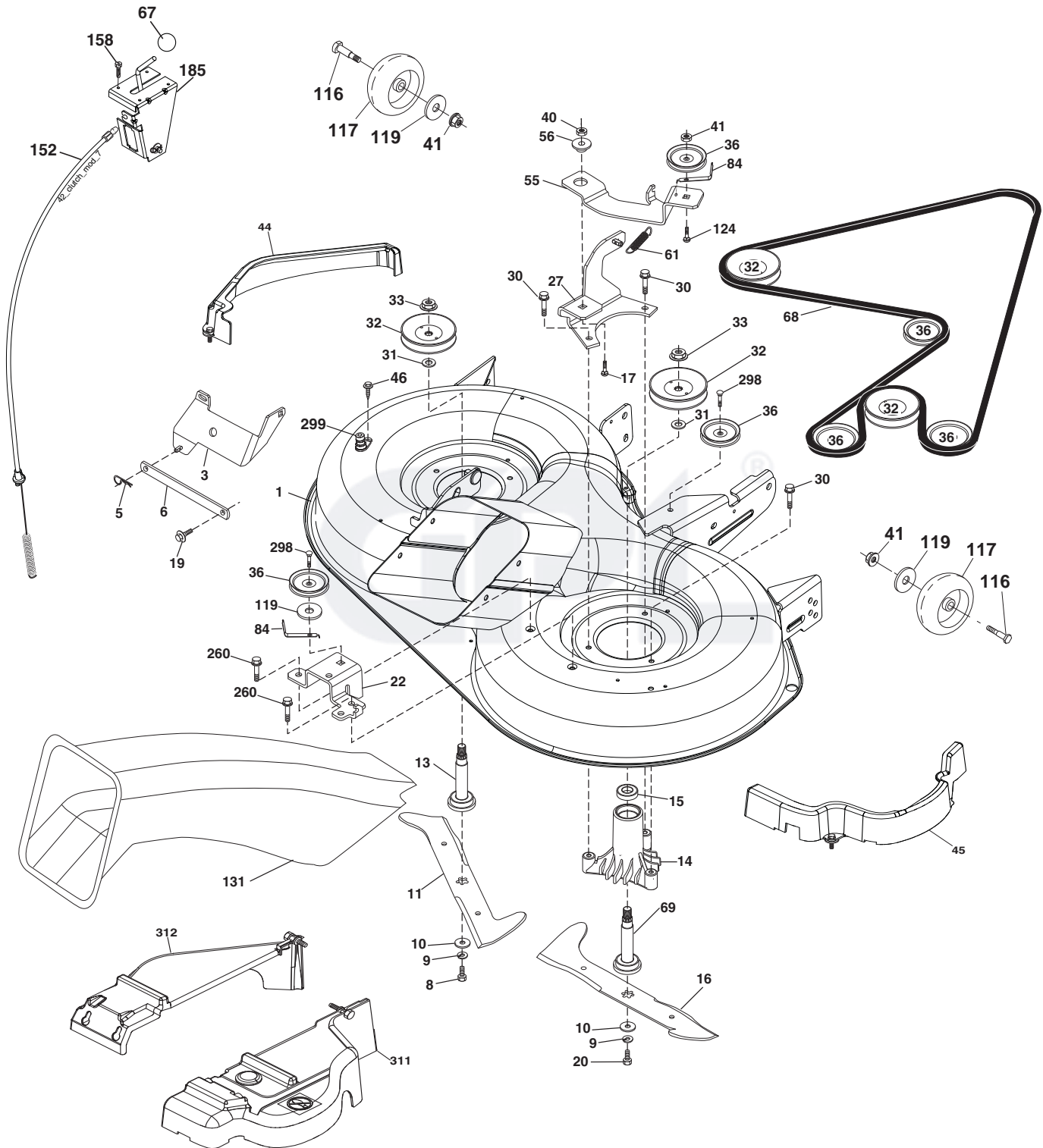

Deck-CRD_97cm_Elect_1_r5

**TRACTOR - - MODEL NO. LT2216CMA2 (96061028300), PRODUCT NO. 960 61 02-83
MOWER DECK 44**

KEY NO.	PART NO.	DESCRIPTION	KEY NO.	PART NO.	DESCRIPTION
1	532 42 91-21	Housing Asm. Mower 97 CRD	61	532 19 94-86	Spring Tension Belt
3	532 43 18-64	Bracket Asm. S-Bar Chass 97 CRD	67	532 10 69-32	Knob Rd 3/8-16
5	532 12 46-70	Retainer Spring	68	532 42 95-32	Belt Drive 97 Mower
6	532 16 55-57	Bar Sway 97 CRD	69	532 16 54-82	Shaft Asm w/Lwr Brg RH Thd CRD
8	532 18 17-12	Bolt 3/8-24 x 1.25 Gr. 8 Patched	84	532 15 60-85	Keeper Belt Idler
9	810 03 06-00	Washer Lock Hvy 3/8 Unplated	116	532 19 34-06	Bolt Shoulder
10	532 14 02-96	Washer Hard	117	532 17 48-73	Wheel Gauge
11	532 42 79-84	Blade 3-1 LH 97 CRD	119	819 13 20-12	Washer 13/32 x 1-1/4 x 12 GA.
13	532 13 76-45	Shaft Asm. w/Lower Bearing	124	872 11 06-12	Bolt Carr Sh 3/8-16 x 1-1/2 Gr. 5
14	532 12 87-74	Housing Mandrel Vented (Machd)	131	532 16 56-61	Chute Bagger CRD 97cm
15	532 11 04-85	Bearing Ball Mandrel	152	532 17 60-74	Cable Clutch
16	532 42 79-85	Blade 3-1 RH 97 CRD	158	817 72 04-08	Screw Thd Cut 1/4-20 x 1/2
17	872 14 06-10	Bolt Carriage 3/8-16 x 1-1/4	185	532 18 82-34	Head Asm. Cable Clutch
19	532 13 28-27	Bolt Shoulder 5/16-18 Thd Form	260	817 67 06-08	Screw Thdrol 3/8-16 x 1/2
20	532 18 17-13	Bolt 3/8-24 x 1.25 Gr. 8 Ptch Lhthd	298	817 49 06-28	Screw Thdrol 3/8-16 x 1-3/4
22	532 43 11-69	Bracket Idler Sprt 97 CRD	299	532 41 55-98	Port Washout
27	532 42 79-81	Bracket Asm. Susp. Rear RH	311	532 43 07-74	Cover Deck RH
30	532 17 39-84	Screw Thd Rolling	312	532 43 07-75	Cover Deck LH
31	532 18 76-90	Washer Spacer Mower Vented	--	532 18 18-57	Mandrel Assembly (Includes hous- ing, shaft assembly, and bear- ing only - pulley/nut/washer and blade bolt/washers not included)
32	532 15 35-32	Mandrel Pulleys	--	532 18 18-58	Mandrel Asm CRD LH Threads SVC
33	532 40 02-34	Nut Flg Top Lock	--	532 43 10-07	Replacement Mower, Complete (Std. Deck - Order separately guage wheel components key nos. 116, 117 & 119)
36	532 14 67-63	Pulley Idler V-Groove Dim 4.25			
40	873 68 06-00	Nut Crownlock 3/8-16 unc			
41	873 90 06-00	Nut Lock Flg. 3/8-16 unc			
44	532 43 02-10	Cover Mandrel LH 97 CRD			
45	532 43 02-09	Cover Mandrel RH 97 CRD			
46	532 13 77-29	Screw Thd Roll 1/4-20 x 5/8			
55	532 19 94-98	Arm Idler 97 CRD			
56	532 16 57-23	Spacer Retainer Mower			

NOTE: All component dimensions given in U.S. inches
1 inch = 25.4 mm

TRACTOR - - MODEL NO. LT2216CMA2 (96061028300), PRODUCT NO. 960 61 02-83
MOWER LIFT 45

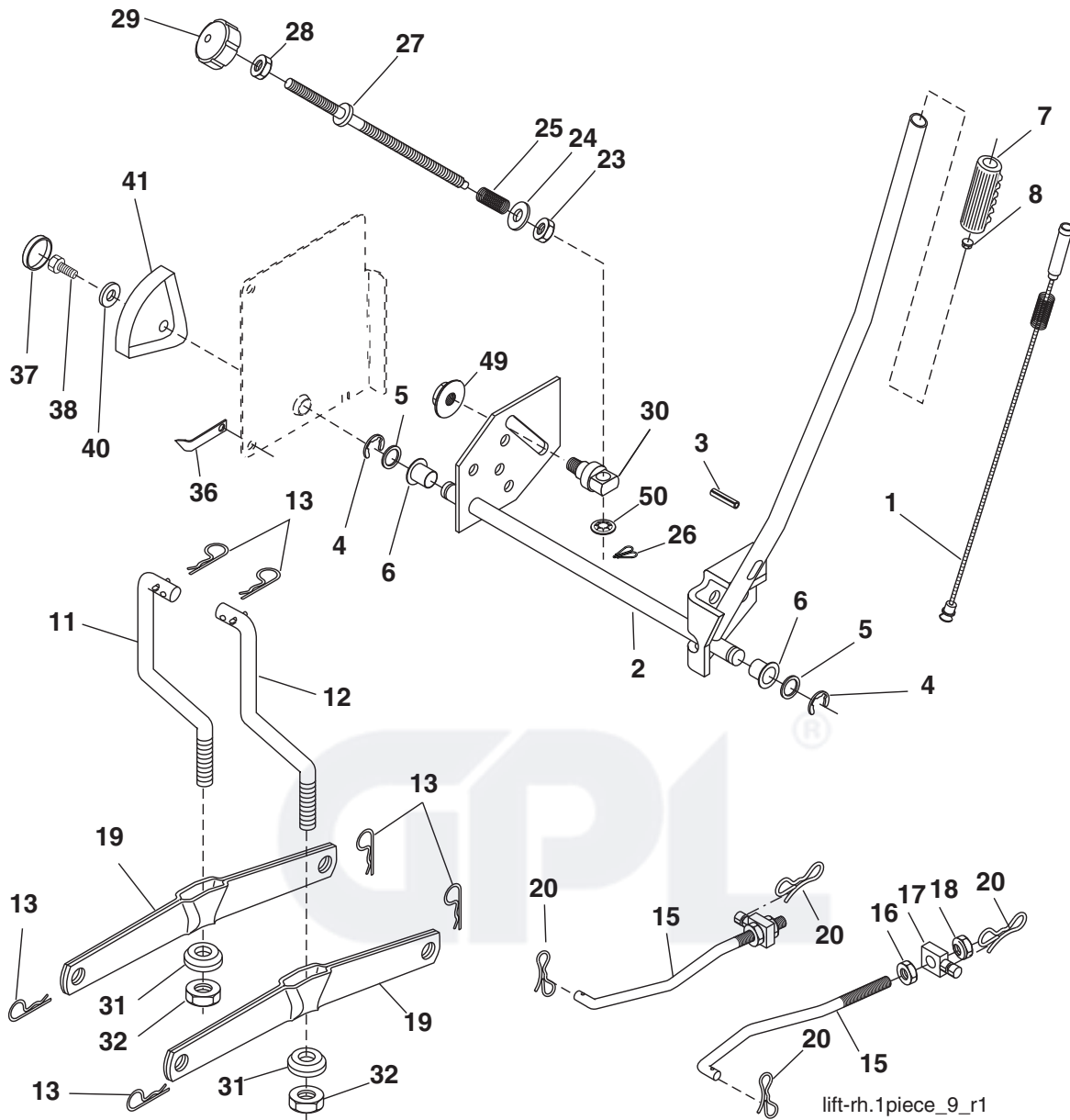

KEY NO.	PART NO.	DESCRIPTION
1	532 40 49-81	Plunger Asm. Lift Lever
2	532 15 94-71	Shaft Asm. Lift
3	532 10 57-67	Pin Groove
4	812 00 00-02	E Ring #5133-62
5	819 21 16-21	Washer 21/32 x 1 x 21 Ga.
6	532 12 01-83	Bearing Nylon
7	532 12 56-31	Grip Handle Fluted
8	532 12 45-26	Button Plunger Black
11	532 13 98-65	Link Asm Lift LH
12	532 13 98-66	Link Asm Lift RH
13	532 12 46-70	Retainer Spring
15	532 17 32-88	Link Front
16	873 35 08-00	Nut Jam Hex 1/2-13 unc
17	532 17 56-89	Trunnion Blk Zinc
18	873 80 08-00	Nut Lock w/Wsh 1/2-13 unc
19	532 13 98-68	Arm Suspension Mower
20	532 19 42-09	Pin Cotter 7/16 Bowtie Lock
23	532 11 08-07	Nut Special

KEY NO.	PART NO.	DESCRIPTION
24	819 13 10-16	Washer 13/32 x 5/8 x 16 Ga.
25	532 12 48-74	Spring 2-1/8"
26	532 16 94-84	Retainer Clip
27	532 12 69-71	Rod Adj Lift Zinc 7.49 Wrk Lg
28	873 35 06-00	Nut Hex Jam 3/8-16 unc
29	532 13 80-57	Knob Inf 3/8-16 unc Blk w/sym
30	532 15 02-33	Trunnion Infin Height
31	532 16 98-65	Bearing, Pvt. Lift.
32	873 54 06-00	Nut Crownlock 3/8-24
36	532 15 50-97	Pointer Height Indicator
37	532 12 39-35	Plug Hole Blk 1.485/1.515 Dia
38	817 06 05-16	Screw 5/16-18 x 1
40	819 11 24-10	Washer 11/32 x 1-1/2 x 10 Ga.
41	532 12 39-34	Scale Ind Height Blk
49	532 14 52-12	Nut Hex Flange Lock
50	532 11 04-52	Nut Push Phos & Oil

NOTE: All component dimensions given in U.S. inches
 1 inch = 25.4 mm

**TRACTOR - - MODEL NO. LT2216CMA2 (96061028300), PRODUCT NO. 960 61 02-83
SEAT ASSEMBLY 42**

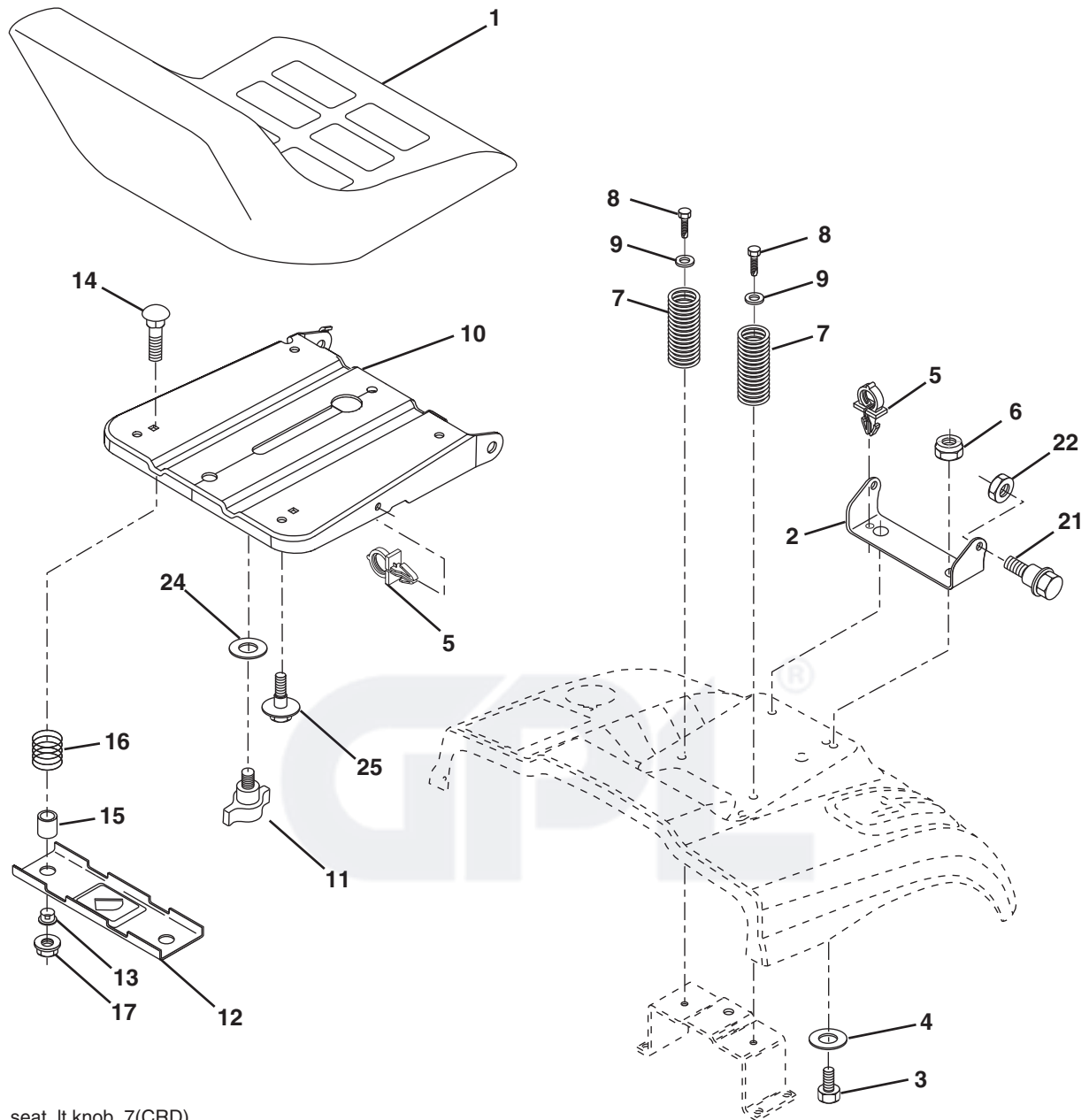

seat_lt.knob_7(CRD)

KEY NO.	PART NO.	DESCRIPTION	KEY NO.	PART NO.	DESCRIPTION
1	532 40 10-43	Seat	13	532 12 12-48	Bushing Snap Blk Nyl 50 Id
2	532 14 05-51	Bracket Pnt Pivot Seat (Blk)	14	872 05 04-12	Bolt Rdhd Sht Nk 1/4-20 x 1-1/2
3	871 11 06-16	Bolt Fin Hex 3/8-16 unc x 1	15	532 12 12-49	Spacer Split
4	819 13 16-10	Washer Flat 13/32 x 1 x 10 Ga.	16	532 12 37-40	Spring Cprsn
5	532 14 50-06	Clip Push In Hinged	17	532 12 39-76	Nut Lock 1/4 Lge Flg Gr. 5 Zinc
6	873 80 06-00	Nut Lock Hex 3/8-16 unc	21	532 17 18-52	Bolt Shoulder 5/16-18 unc-2A
7	532 12 41-81	Spring Seat Cprsn 2 250 Blk Zi	22	873 80 05-00	Nut Hex Lock w/Ins 5/16-18
8	817 00 06-16	Screw 3/8-16 x 1-1/2	24	819 17 19-12	Washer 17/32 x 1-3/16 x 12 Ga.
9	819 13 16-14	Washer 13/32 x 1 x 14 Ga.	25	532 12 70-18	Bolt Shoulder 5/16-18 x .62
10	532 19 55-30	Pan Pnt Seat (Blk)			
11	532 16 63-69	Knob Seat			
12	532 17 46-48	Bracket Pnt Mounting Switch			

NOTE: All component dimensions given in U.S. inches
1 inch = 25.4 mm

**TRACTOR - - MODEL NO. LT2216CMA2 (96061028300), PRODUCT NO. 960 61 02-83
BAGGER **46****

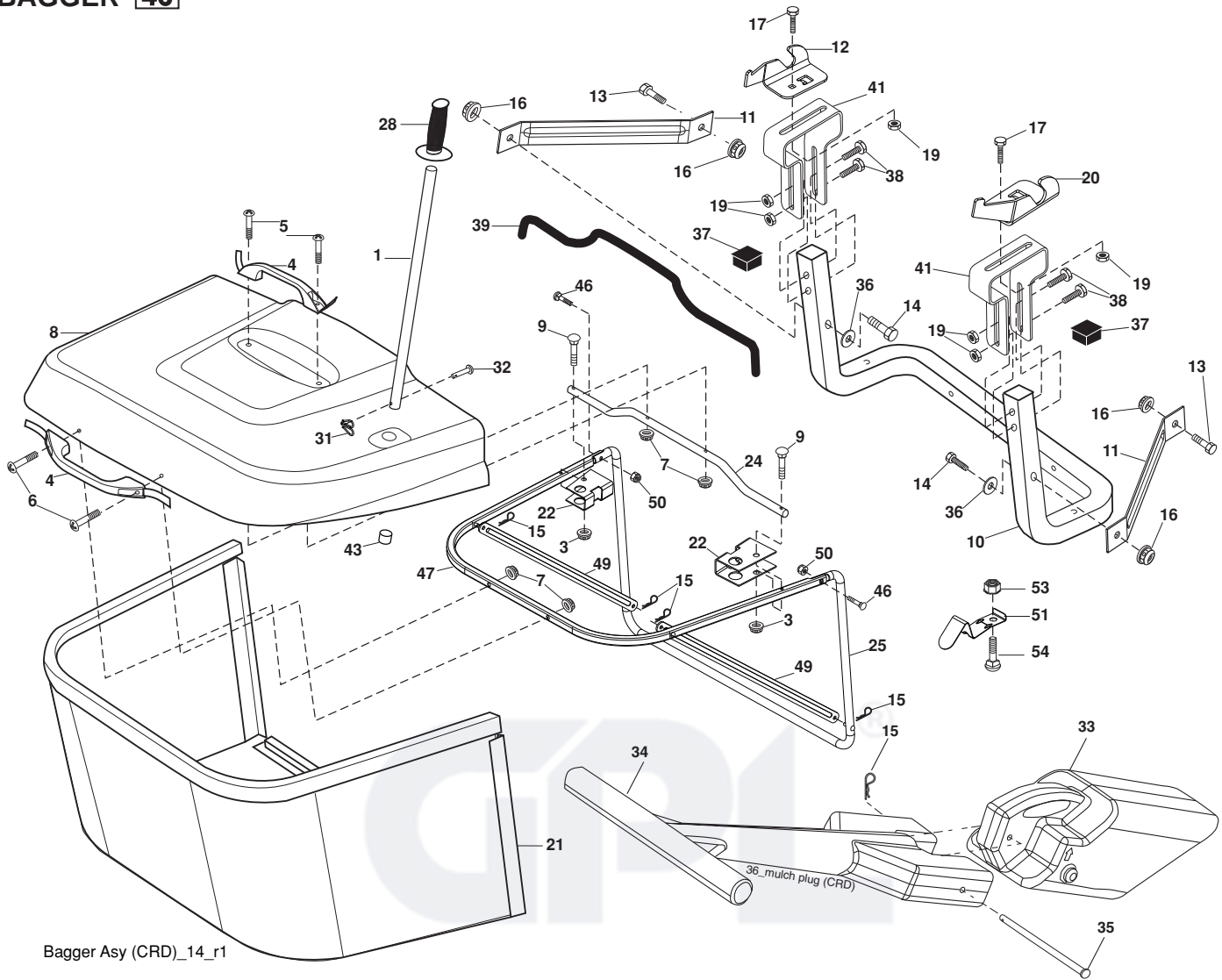

Bagger Asy (CRD)_14_r1

KEY NO.	PART NO.	DESCRIPTION	KEY NO.	PART NO.	DESCRIPTION
1	532 42 86-10	Tube Handle Bagger CRD	28	532 16 57-87	Grip Handle Black
3	532 12 39-76	Nut Lock 1/4 Lge Flg Gr. 5 Zinc	31	532 16 94-84	Retainer Clip
4	532 16 99-16	Handle Bagger w/Lvrs Gr. 5 Zinc	32	532 12 68-75	Rivet Rd Hd Drilled 3/8 Dia
5	874 98 10-24	Screw Pan Head #10-24 x 1.50 Blk	33	532 42 86-83	Plug Mulch
6	874 98 10-32	Screw Pan Hd	34	532 16 55-70	Handle Mulcher
7	873 40 10-00	Nut Wiz Lock Hex Serr/Hd #10-24	35	532 16 55-72	Pin Mulcher
8	532 18 13-54	Cover Bagger Steel	36	819 13 20-12	Washer 13/32 x 1-1/4 x 12 Ga.
9	872 14 04-18	Bolt Carriage 1/4-20 x 2.25d x Gr. 5	37	532 17 54-01	Plug Support Bagger CRD
10	532 18 12-82	Tube Support Bagger CRD	38	872 01 05-20	Bolt 5/16-18 x 2-1/2
11	532 16 57-19	Bracket Support Upper Bag CRD	39	532 41 62-57	Seal Bagger
12	532 18 88-48	Bracket Pivot LH	41	532 43 27-55	Bracket Vert Adj Bagger CRD
13	874 76 06-12	Bolt Fin Hex 3/8-16 unc x 3/4	43	532 17 40-83	Plug Tubing End
14	874 52 06-36	Bolt Fin Hex 3/8-16 x 2 x 1/4 Gr. 5	46	872 11 05-10	Bolt Carr. 5/16-18 x 1-1/4 Gr. 5
15	532 12 46-70	Retainer Spring	47	532 19 37-04	Tube Upper Bagger
16	873 90 06-00	Nut Fock Flg 3/8-16 unc	49	532 19 33-05	Bar Spreader Bagger
17	872 14 05-06	Bolt Rdhd Sht Sqnk 5/16-18 unc x 3/4	50	873 80 05-00	Nut Lock Hex w/Insert 5/16-18 unc
19	873 90 05-00	Nut Lock Hex Flange 5/16-18	51	532 19 99-03	Latch Spring Bagger
20	532 18 88-47	Bracket Pivot RH	53	873 51 04-00	Nut Keps Hex 1/4-20 unc
21	532 40 61-80	Bag Asm CRD	54	872 14 04-06	Bolt RDHD SQNK 1/4-20 x 3/4 Gr. 5
22	532 16 57-81	Bracket Side Bagger CRD			
24	532 16 57-83	Tube Pivot Bagger CRD			
25	532 19 37-05	Tube Front Bagger CRD			

NOTE: All component dimensions given in U.S. inches
1 inch = 25.4 mm

