

LT2218A2

Spare parts

Ersatzteile

Pièces détachées

Reserve onderdelen

Repuestos

Reservdelar



ILLUSTRATED PARTS LIST

MFG. ID NO. 96041003900

CUSTOMER CATALOG NO. LT2218A2

PRODUCT NO. 960 41 00-39

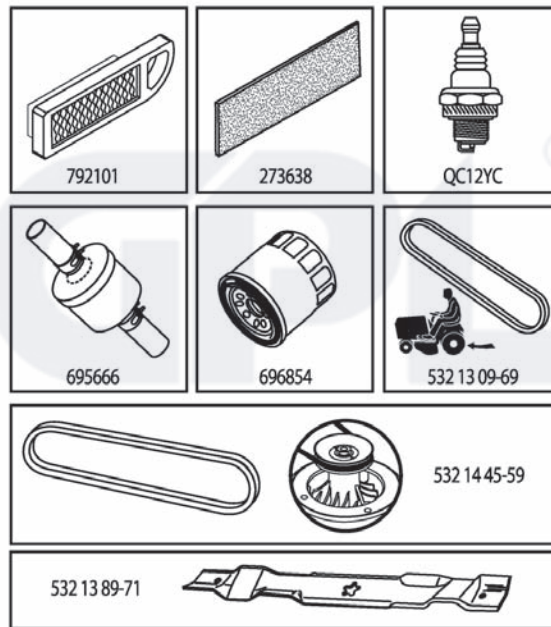

**TRACTOR - MODEL NO. LT2218A2 (96041003900), PRODUCT NO. 960 41 00-39
DECALS**

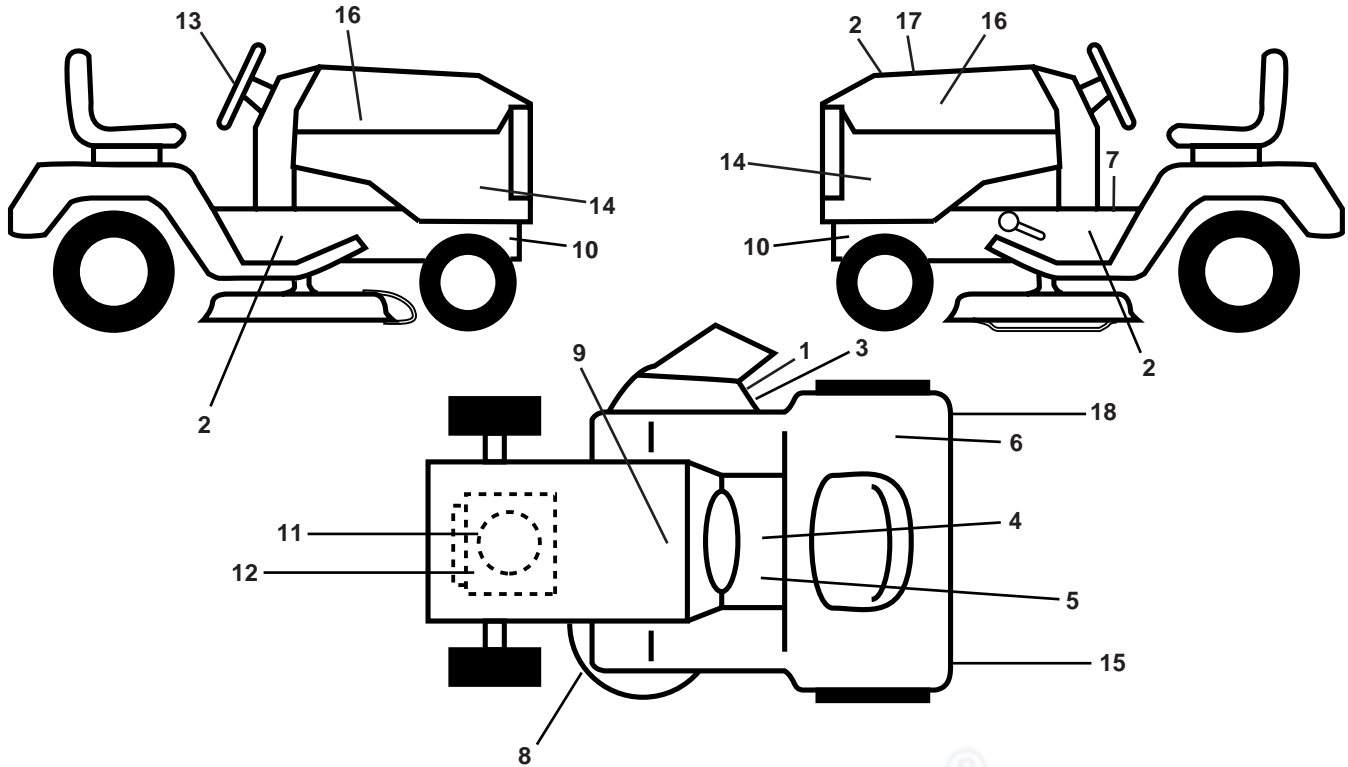

KEY NO.	PART NO.	DESCRIPTION
1	532 18 21-66	Decal, Cutfinger Warning
2	532 19 68-42	Decal, Cutfinger
3	532 19 63-57	Decal, Warning Symbol
4	532 14 08-37	Decal, Brake Parking
5	532 40 03-89	Decal, Warning Symbol CE
6	532 18 04-32	Decal, Fender DB/CE
7	532 15 97-37	Decal, Brake/Clutch Symbol
8	532 16 03-96	Decal, Mower Sch.
9	532 14 50-05	Decal, Battery Dnge/Poi
10	532 15 97-36	Decal, Hot Muffler
11	532 19 68-41	Decal, Warning Engine Sym

KEY NO.	PART NO.	DESCRIPTION
12	532 40 94-62	Decal, Engine HP
13	532 18 57-73	Decal, Steering Whl
14	532 40 93-72	Decal, Panel Side
15	532 18 39-30	Decal, Cover/Belt
16	532 18 95-53	Decal, Hood Logo
17	532 40 86-68	Decal, Replacement
18	532 40 93-73	Decal, Fender
--	532 16 69-60	Decal, Bypass
--	532 16 25-98	Decal, Load Limit
--	532 41 19-03	Pad, Footrest, LH
--	532 41 19-02	Pad, Footrest, RH
--	532 40 85-80	Manual Oper. Euro

WHEELS AND TIRES

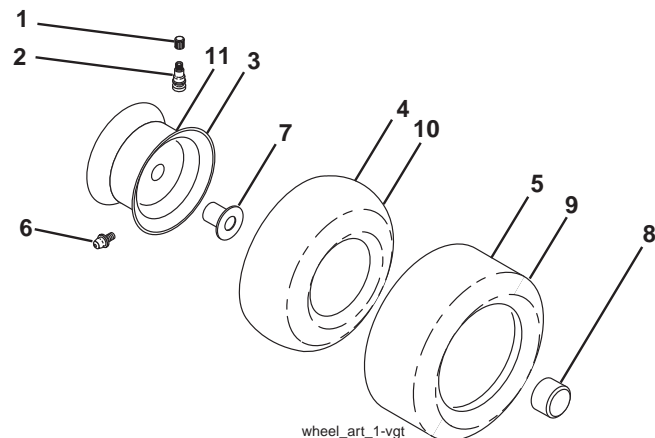

KEY NO.	PART NO.	DESCRIPTION
1	532 05 91-92	Cap, Valve, Tire
2	532 06 51-39	Stem, Valve
3	532 13 83-36	Rim Assembly, Front
4	532 05 99-04	Tube, Front (Service Item Only)
5	532 10 62-22	Tire, Front
6	532 12 49-57	Fitting, Grease (Front Wheel Only)
7	532 19 49-59	Bearing, Flange (Front Wheel Only)
8	532 17 50-39	Cap, Axle (Front Wheel Only)
9	532 12 20-82	Tire, Rear
10	532 12 49-26	Tube, Rear (Service Item Only)
11	532 13 83-37	Rim Assembly, Rear
--	532 14 43-34	Sealant, Tire (10 oz. Tube)

NOTE: All component dimensions given in U.S. inches
1 inch = 25.4 mm

TRACTOR - MODEL NO. LT2218A2 (96041003900), PRODUCT NO. 960 41 00-39 SCHEMATIC

194276_Regulated-Tex (12V)

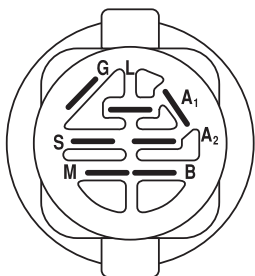
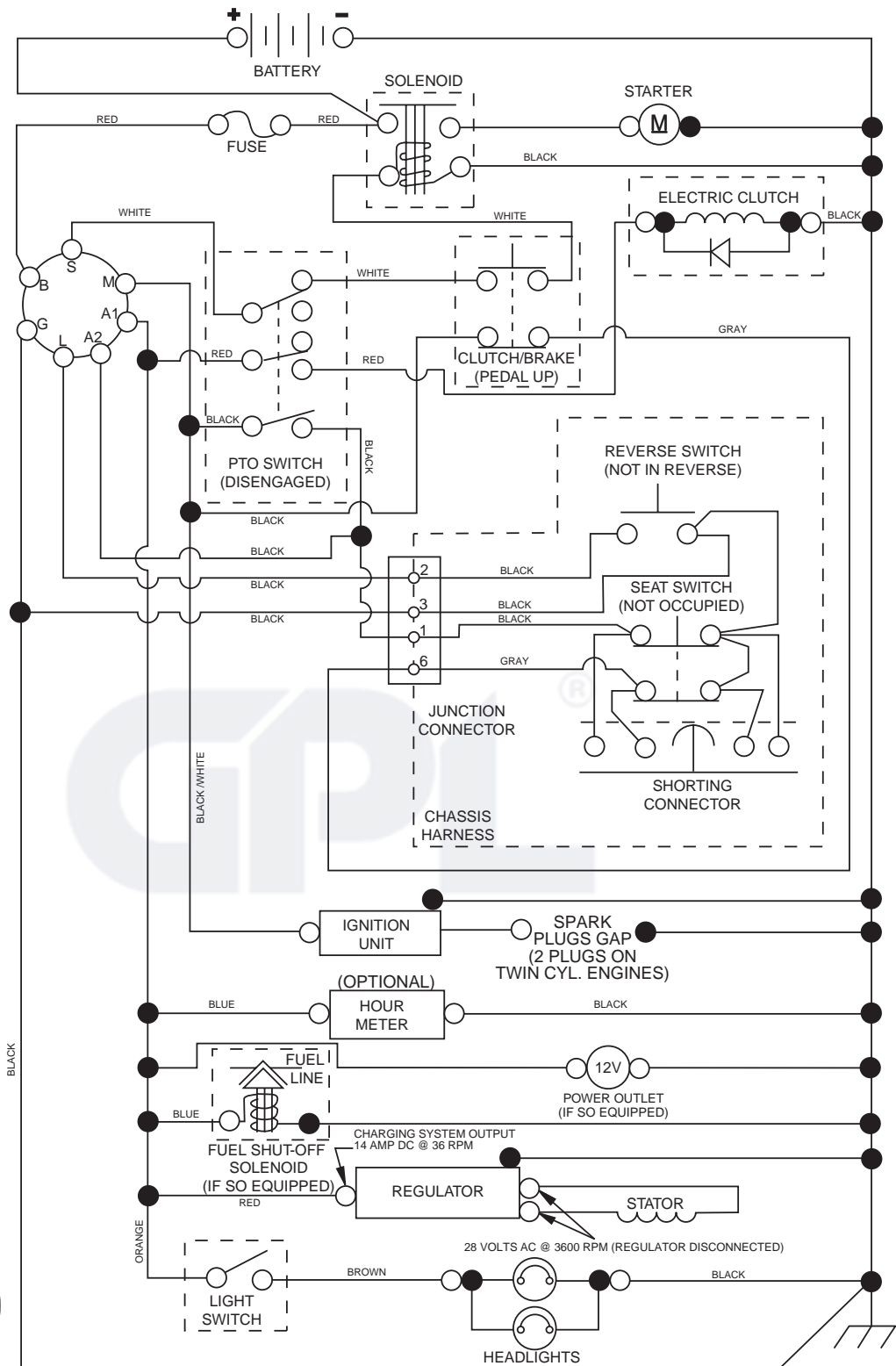

IGNITION SWITCH

POSITION	CIRCUIT	"MAKE"
OFF	M+G+A1	
RUN/OVERRIDE	B+A1	
RUN	B+A1	L+A2
START	B + S + A1	

03025

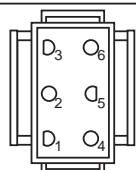

CHASSIS HARNESS CONNECTOR (MATING SIDE)

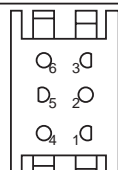

DASH HARNESS CONNECTOR (MATING SIDE)

WIRING INSULATED CLIPS
NOTE: IF WIRING INSULATED CLIPS WERE REMOVED FOR SERVICING OF UNIT, THEY SHOULD BE REPLACED TO PROPERLY SECURE YOUR WIRING.

●
NON-REMOVABLE CONNECTIONS

○
REMOVABLE CONNECTIONS

**TRACTOR - MODEL NO. LT2218A2 (96041003900), PRODUCT NO. 960 41 00-39
ELECTRICAL**

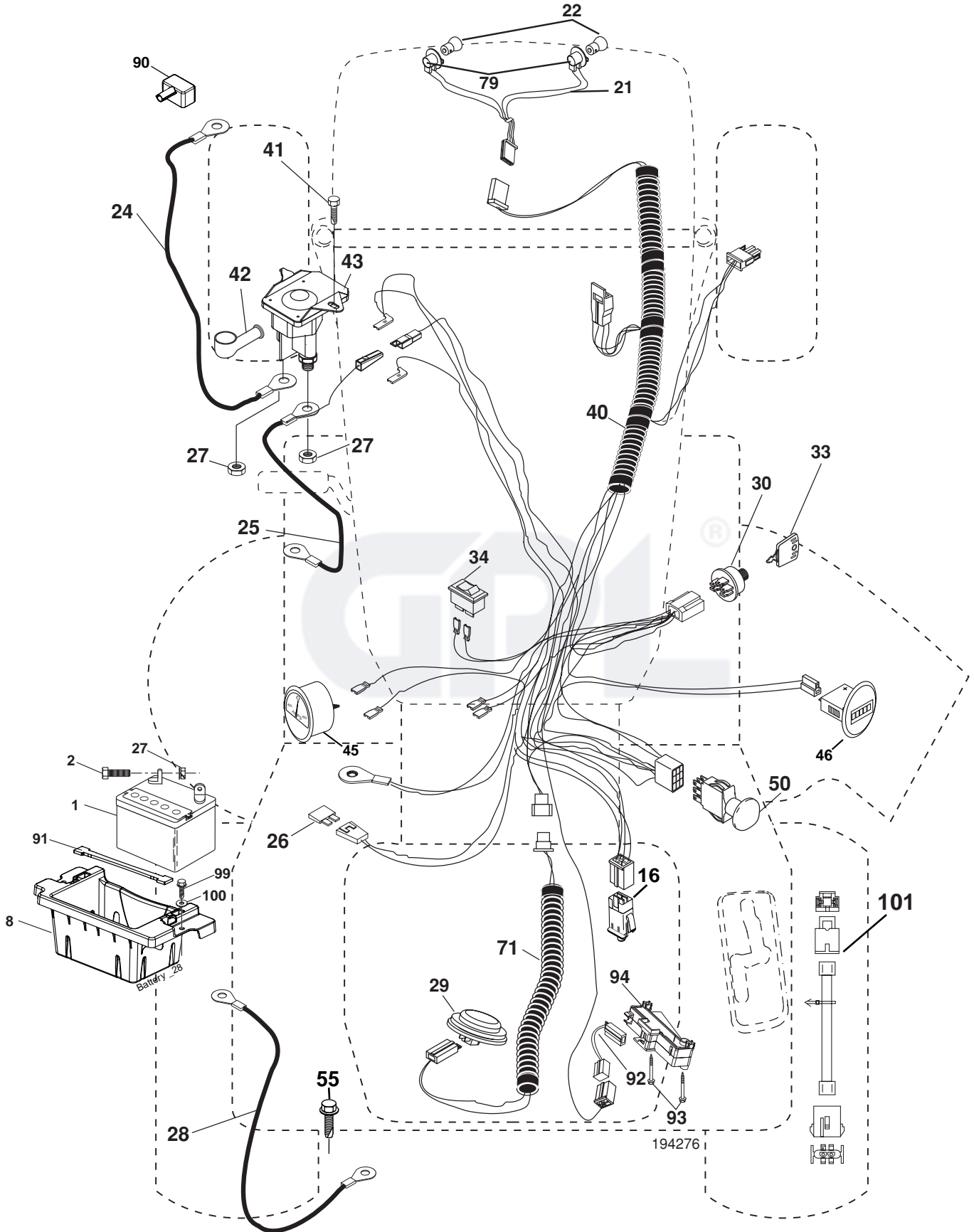

194276

**TRACTOR - MODEL NO. LT2218A2 (96041003900), PRODUCT NO. 960 41 00-39
ELECTRICAL**

KEY NO.	PART NO.	DESCRIPTION
1	532 14 49-27	Battery
2	874 76 04-12	Bolt Hex Hd 1/4-20 unc x 3/4
8	532 18 64-91	Battery Box
16	532 17 61-38	Switch Interlock
21	532 17 56-88	Harness Socket Light
22	532 00 41-52	Bulb, Light # 1156
24	532 40 02-53	Cable Battery
25	532 19 88-93	Cable Starter
26	532 17 51-58	Fuse
27	873 51 04-00	Nut Keps Hex 1/4-20 unc
28	532 14 54-91	Cable Ground 21" Blk 6 Ga.
29	532 40 15-45	Switch Seat
30	532 19 33-50	Switch Ign
33	532 14 04-01	Key Ign Molded Generic
34	532 11 07-12	Switch Light/Reset
40	532 40 21-67	Harness Ign. Dash
41	817 72 04-08	Screw Thd Cut 1/4-20 x 1/2
42	532 13 15-63	Cover Terminal Red
43	532 19 25-07	Solenoid
45	532 17 75-00	Ammeter
46	532 17 75-01	Gauge Hourmeter
50	532 17 46-51	Switch PTO
55	817 06 05-12	Screw Thdrol 5/16-18 x 3/4
71	532 19 42-76	Harness Chassis
79	532 17 52-42	Socket Asm Bulb Twistlock
90	532 40 07-24	Cover Terminal Battery
91	532 19 02-70	Strap Battery
92	532 19 66-15	Harness Pigtail Console
93	532 19 25-40	Screw Plastic 10-14 x 2.0
94	532 19 18-34	Module Reverse
99	817 67 04-12	Screw Hexwsh Thdrol 1/4-20 x 3/4
100	819 09 14-16	Washer 9/32 x 7/8 x 16 Ga.
101	532 19 83-17	Pigtail Harness

NOTE: All component dimensions given in U.S. inches
1 inch = 25.4 mm

TRACTOR - MODEL NO. LT2218A2 (96041003900), PRODUCT NO. 960 41 00-39 CHASSIS

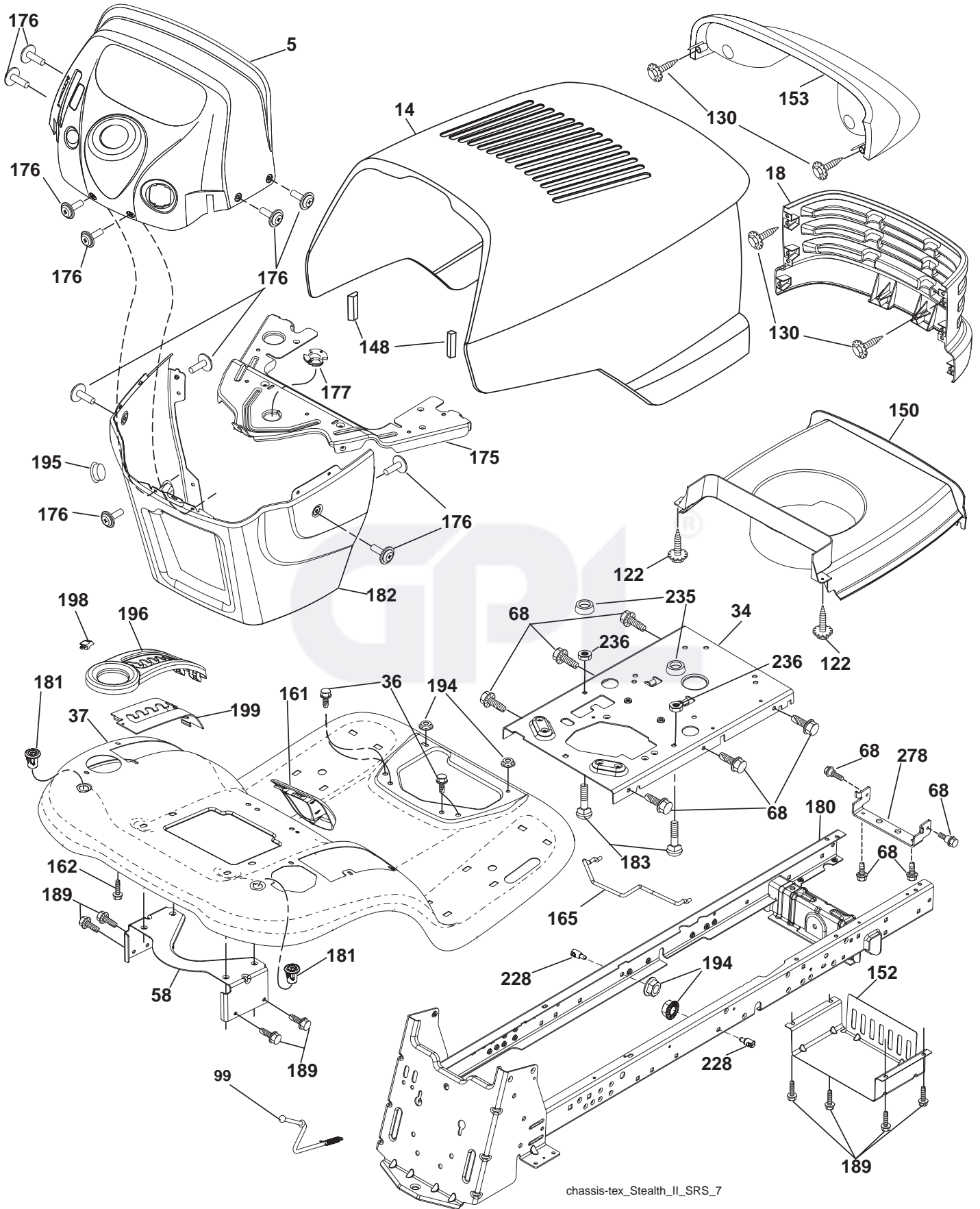

**TRACTOR - MODEL NO. LT2218A2 (96041003900), PRODUCT NO. 960 41 00-39
CHASSIS**

KEY NO.	PART NO.	DESCRIPTION
5	532 41 18-76	Dash
14	532 18 13-51	Hood
18	532 18 13-52	Grille
34	532 19 61-25	Plate Engine
36	817 06 05-12	Screw 5/16-18 x 3/4
37	532 41 18-77	Fender
58	532 19 43-14	Bracket Fender
68	817 49 05-08	Screw 5/16-18 x 1/2
99	532 40 59-17	Rod Bypass Asm.
122	532 19 25-12	Screw Hex 10-32 x 5/8
130	532 19 16-11	Screw 10 x 3/4 Single Lead Hex
148	532 16 46-55	Bumper Extrusion
150	532 17 53-51	Duct Heat Hood
152	532 19 95-35	Shield Browning/Debris
153	532 16 18-40	Lens Bar
161	532 41 18-79	Console Fuel Window
162	532 14 24-32	Screw Hex Wsh Hi-Lo 1/4 x 1/2
165	532 19 68-26	Bracket Support Tank
175	532 19 32-36	Crossmember
176	532 40 07-76	Screw 10-24 x 5/8 Rnd Qdrx
177	532 19 52-27	Bushing Steering
180	532 40 15-59	Chassis
181	532 40 47-96	Bushing Mtg. Fender Crgo.
182	532 19 25-51	Dash Lower
183	874 78 05-20	Bolt Hex 5/16-18 x 1-1/4
189	817 00 05-12	Screw 5/16-18 x 3/4
194	873 90 05-00	Nut Lock Hex Flange 5/16-18
195	532 40 41-37	Plug 12v Adapter
196	532 41 18-80	Console Asm. Deck Lift
198	532 41 18-81	Indicator Deck Lift
199	532 19 63-77	Plate Deck Lift
228	532 19 51-61	Stud Fastner
235	532 40 61-29	Spacer Fender
236	873 93 05-00	Nut Center Lock 5/16-18 unc
278	532 19 63-94	Bracket Hood/Muffler
--	532 41 14-11	Phone Holder

NOTE: All component dimensions given in U.S. inches
1 inch = 25.4 mm

TRACTOR - MODEL NO. LT2218A2 (96041003900), PRODUCT NO. 960 41 00-39 DRIVE

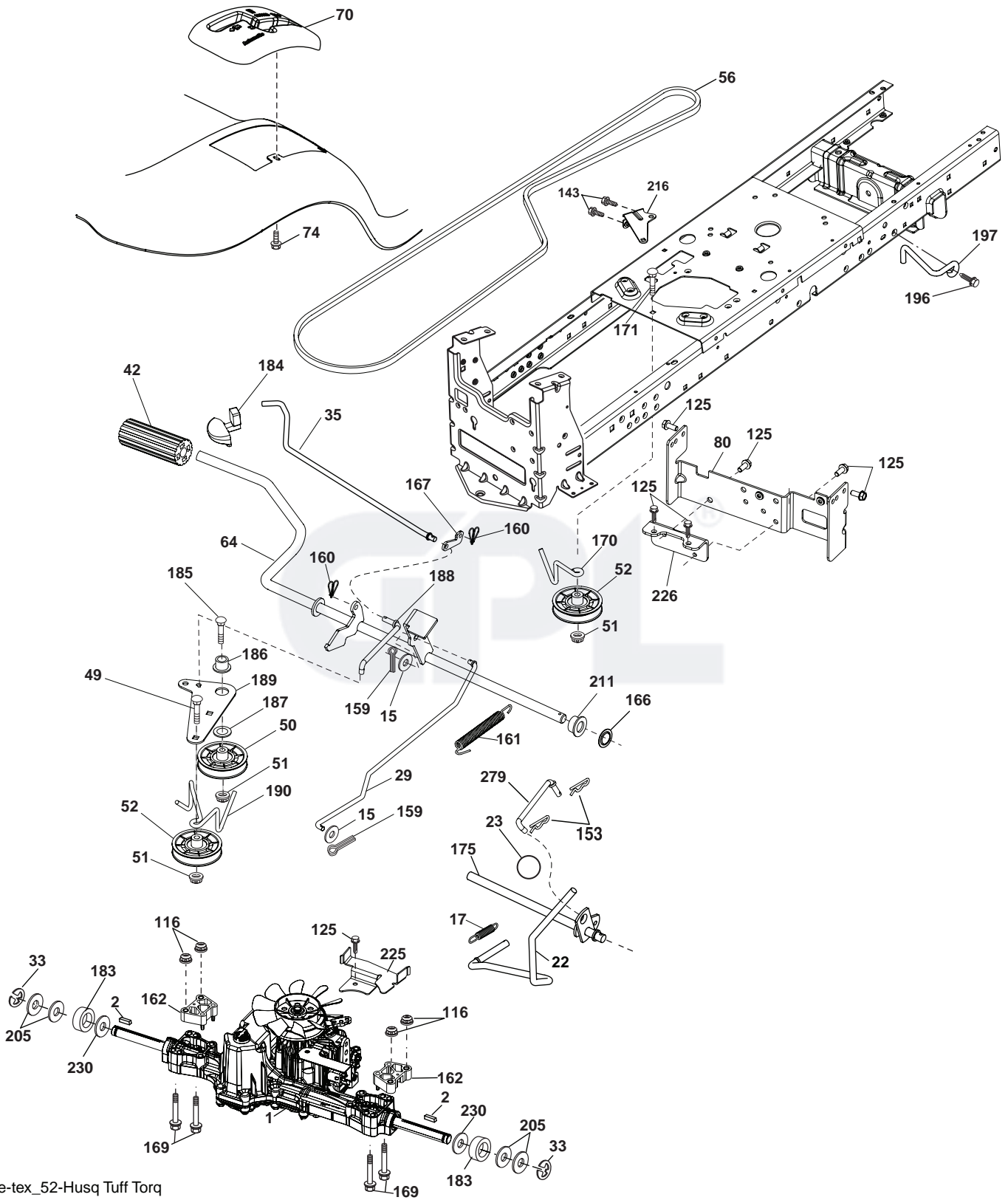

**TRACTOR - MODEL NO. LT2218A2 (96041003900), PRODUCT NO. 960 41 00-39
DRIVE**

KEY NO.	PART NO.	DESCRIPTION
1	-----	Transaxle, TUFFTORQ K46 (Order From Transaxle Mfgr.)
2	532 12 35-83	Key
15	819 13 13-16	Washer 13/32 x 13/16 x 16 Ga.
17	532 41 36-78	Spring, Brake
22	532 40 05-04	Shifter Asm
23	532 13 05-64	Knob Deluxe
29	532 40 38-06	Rod, Brake
33	812 00 00-01	Ring E
35	532 19 72-75	Rod, Brake, Park
42	532 12 48-72	Cover, Foot Pedal
49	872 11 06-14	Bolt
50	532 19 43-27	Pulley Idler Flat
51	873 90 06-00	Lock Nut 3/8-16
52	532 19 43-26	Idler V-Groove 910" Offset
56	532 13 09-69	V-Belt, Drive
64	532 19 62-00	Shaft Asm. Pedal Brake Control
70	532 41 19-01	Console Asm.
74	532 14 24-32	Screw 1/4 x 1/2
80	532 40 44-83	Bracket Strap Torque
116	873 90 05-00	Nut Lock Hex Flange 5/16-18
125	817 00 05-12	Screw 5/16-18 x 3/4
143	817 49 05-08	Screw Thdrol 5/16-18 x 1/2
153	532 12 47-88	Retainer Spring
159	876 02 04-12	Pin Cotter 1/8 x 3/4
160	532 16 94-84	Retainer Clip
161	532 19 54-03	Spring, Return, Clutch
162	532 19 57-85	Spacer Transaxle
167	532 40 52-57	Latch Brake Parking
169	874 49 05-60	Bolt Hex Flghd 5/16-18 x 3.75
170	532 19 43-22	Keeper Belt Centerspan
171	872 11 06-16	Bolt Rdhd Sqnk 3/8-16 unc x 2
175	532 40 62-08	Shaft Asm. Shift
183	532 13 70-57	Spacer Split
184	532 41 17-16	Handle Parking Brake
185	872 11 06-20	Bolt Rdhd Sqnk 3/8-16 x 2-1/2
186	532 19 43-21	Spacer Retainer
187	819 13 32-10	Washer
188	532 19 43-23	Link Clutch Ground Drive
189	532 19 43-17	Bellcrank Ground Drive
190	532 19 43-18	Keeper Bellcrank Ground Drive
196	817 00 06-16	Screw 3/8-16 x 1
197	532 19 58-04	Bracket Clutch Anti-Rotation
205	532 12 17-48	Washer
211	532 12 01-83	Bearing Nylon
216	532 19 61-31	Bracket Pulley Idler
225	532 40 33-19	Keeper Belt Trans.
226	532 40 08-31	Bracket Mount Torque
230	532 18 89-67	Washer Hardened
279	532 40 62-07	Link Shift

NOTE: All component dimensions given in U.S. inches
1 inch = 25.4 mm

**TRACTOR - MODEL NO. LT2218A2 (96041003900), PRODUCT NO. 960 41 00-39
MOWER DECK**

KEY NO.	PART NO.	DESCRIPTION
1	532 19 64-95	Mower Deck Assembly, 42"
2	532 40 92-58	Cover Mandrel RH
3	532 40 92-59	Cover Mandrel LH
6	532 19 51-86	Arm Susp. Rear
8	532 19 30-03	Bolt/Washer Asm 7/16-20 unf
11	532 13 89-71	Blade Mower 42" Hi-Lift (For Bagging and Discharging)
13	532 19 28-72	Shaft Assembly, Mandrel
14	532 18 72-81	Housing, Mandrel
15	532 11 04-85	Bearing, Ball, Mandrel
16	532 17 44-93	Stripper, Mandrel Deck
19	532 19 65-39	Bolt, Shoulder
20	532 15 97-70	Baffle, Vortex
21	873 68 05-00	Nut
23	532 19 25-57	Bracket, Deflector Mower 42"
24	532 10 53-04	Cap, Sleeve 80 x 112 Blk Mower
25	532 19 70-26	Spring, Torsion, Deflector
26	532 11 04-52	Nut, Push Phos & Oil
27	532 41 14-85	Shield, Deflector 42" Blk
29	532 13 14-91	Rod, Hinge 42" 6 75 W/G
30	532 17 39-84	Screw Thdrol
31	532 18 76-90	Washer, Spacer Mower Vented
32	532 15 35-35	Pulley, Mandrel
33	532 40 02-34	Nut, Toplock
34	872 11 06-12	Bolt Carr SH 3/8-16 x 1-1/2 Gr. 5
36	532 19 73-79	Pulley, Idler, Flat
40	873 90 06-00	Nut Lock 3/8-16
46	532 13 77-29	Screw 1/4-20 x 5/8
55	532 19 72-49	Arm, Idler
56	532 19 90-92	Spacer, Retainer
57	817 00 06-16	Screw 3/8-16 x 1
59	532 14 10-43	Guard TUV Idler
62	872 11 06-16	Bolt Rdhd Sqnk 3/8-16 unc x 2
68	532 14 49-59	V-Belt, 42" Mower
69	872 14 05-05	Bolt, Carriage 5/16-18 x 5/8
116	532 12 48-42	Bolt, Shoulder
117	532 18 86-06	Wheel, Gauge
118	873 93 06-00	Nut Centerlock 3/8-16 unc
119	819 12 14-14	Washer 3/8 x 7/8 x 14 Ga.
145	532 19 31-97	Pulley Idler
188	532 19 51-61	Stud Fastner W/D Anti-Rotation
189	873 90 05-00	Nut Lock Hex Flange 5/16-18
190	532 19 72-51	Spring Mower Drive
280	817 67 06-08	Screw 3/8-16 x 1/2
--	532 19 28-70	Mandrel Assembly (Includes Housing Shaft and Shaft Hardware Only - Pulley Not Included)
--	532 40 85-50	Replacement Mower, Complete (Std. Deck Order Separately Gauge Wheel Components Key Nos. 116-119)

NOTE: All component dimensions given in U.S. inches
1 inch = 25.4 mm

**TRACTOR - MODEL NO. LT2218A2 (96041003900), PRODUCT NO. 960 41 00-39
ENGINE**

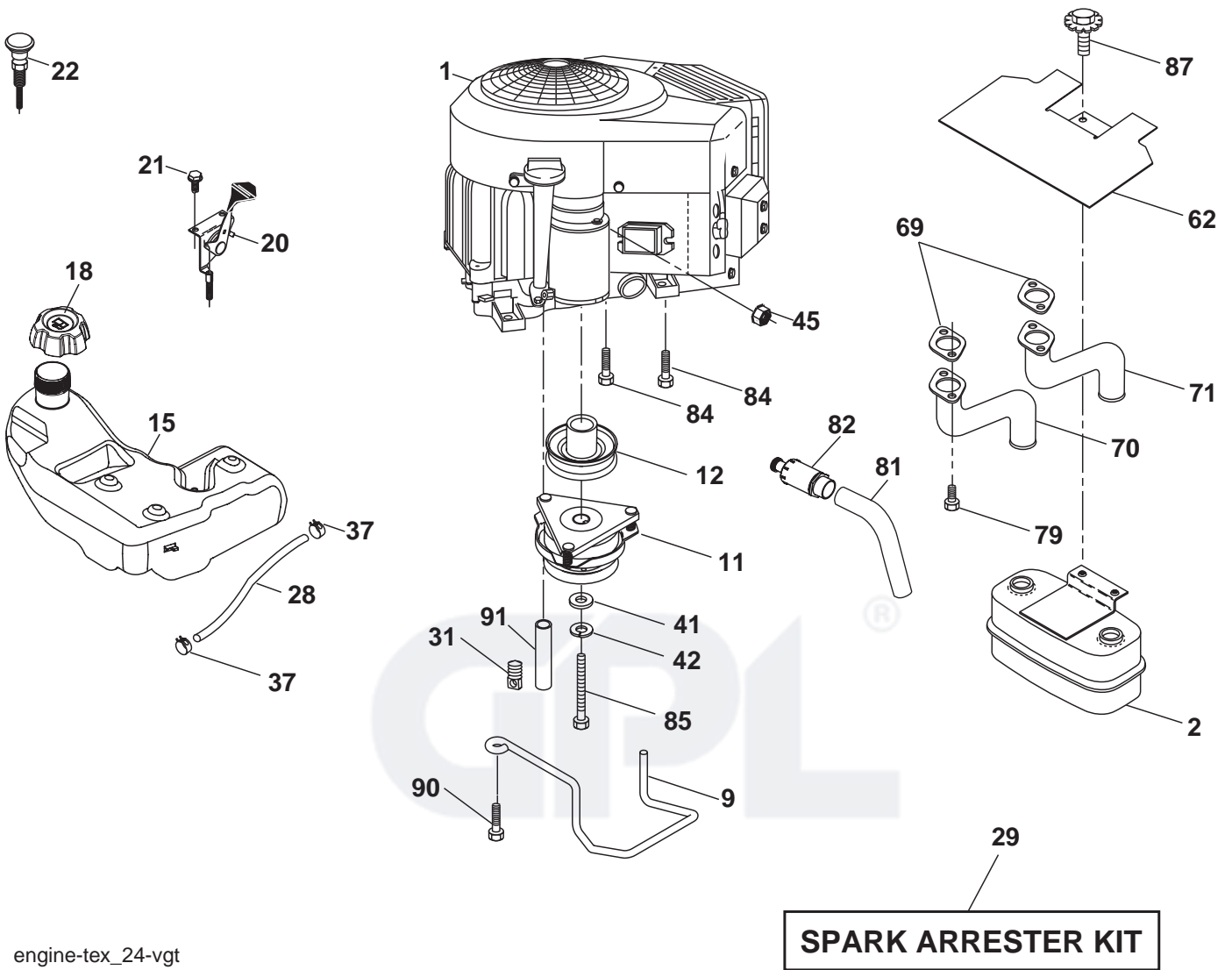

engine-tex_24-vgt

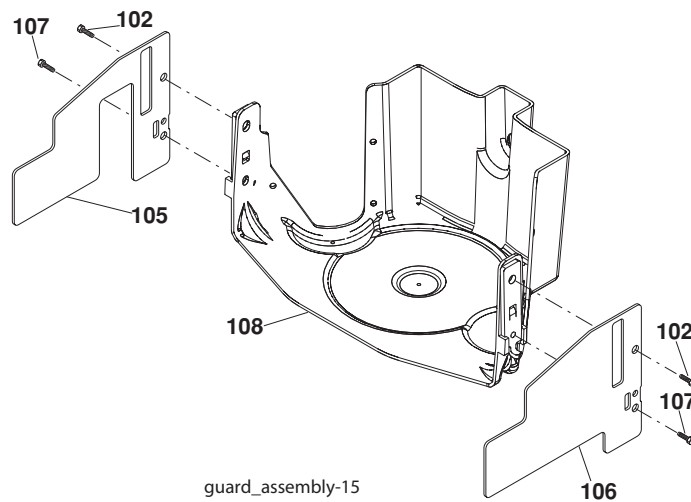

TRACTOR - MODEL NO. LT2218A2 (96041003900), PRODUCT NO. 960 41 00-39 ENGINE

KEY NO.	PART NO.	DESCRIPTION
1	-----	Engine Briggs Model No. 405577
2	532 14 97-23	Muffler
9	532 19 43-20	Keeper Belt Engine
11	532 18 05-05	Clutch Electric
12	532 40 50-97	Pulley Engine
15	532 19 34-99	Tank Fuel
18	532 19 59-51	Cap Asm
20	532 17 83-85	Control Throttle
21	532 19 16-11	Screw 10 x 3/4 Single Lead Hex
22	532 19 15-96	Control Choke
28	532 14 21-58	Fuel Line
29	532 13 71-80	Spark Arrester Kit
31	532 14 50-06	Clip Push-In
37	532 12 34-87	Clamp Hose
41	532 12 61-97	Washer 1-1/2 OD x 15/32 ID x .250
42	810 04 07-00	Washer Lock 7/16
45	873 51 04-00	Nut Keps Hex 1/4-20 unc
62	532 14 66-29	Shield Heat Muffler
69	532 16 53-91	Gasket Muffler
70	532 15 99-55	Tube Exhaust LH
71	532 16 05-89	Tube Exhaust RH
79	532 18 39-06	Screw Socket Head 5/16-18 x 1
81	532 14 84-56	Tube Drain Oil Easy
82	532 18 16-54	Plug Drain Oil Easy
84	817 06 06-20	Screw 3/8-16 x 1-1/4
85	532 17 39-37	Bolt Hex 7/16-20 x 4 x Gr. 5-1.5
87	532 19 82-39	Bolt 5/16-18 unc x 1 w/Sems
90	817 00 06-16	Screw 3/8-16 x 1
91	532 18 74-95	Bushing
102	817 00 05-12	Screw 5/16-18 x 3/4
105	532 41 05-28	Shield Side LH
106	532 41 05-29	Shield Side RH
107	532 13 77-29	Screw 1/4-20 x 5/8
108	532 41 05-32	Cover Asm. Engine

NOTE: All component dimensions given in U.S. inches
1 inch = 25.4 mm

Engine Power Rating Information

The gross power rating for individual gas engine models is labeled in accordance with SAE (Society of Automotive Engineers) code J11940 (Small Engine Power & Torque Rating Procedure), and rating performance has been obtained and corrected in accordance with SAE J1995 (Revision 2002-5). Actual gross engine power will be lower and is affected by, among other things, ambient operating conditions and engine-to-engine variability. Given both the wide array of products on which engines are placed and the variety of environmental issues applicable to operating the equipment, the gas engine will not develop the rated gross power when used in a given piece of power equipment (actual "on-site" or net horsepower). This difference is due to a variety of factors including, but not limited to, accessories (air cleaner, exhaust, charging, cooling, carburetor, fuel pump, etc.), application limitations, ambient operating conditions (temperature, humidity, altitude), and engine-to-engine variability. Due to manufacturing and capacity limitations, Briggs & Stratton may substitute an engine of higher rated power for this Series engine.

**TRACTOR - MODEL NO. LT2218A2 (96041003900), PRODUCT NO. 960 41 00-39
STEERING ASSEMBLY**

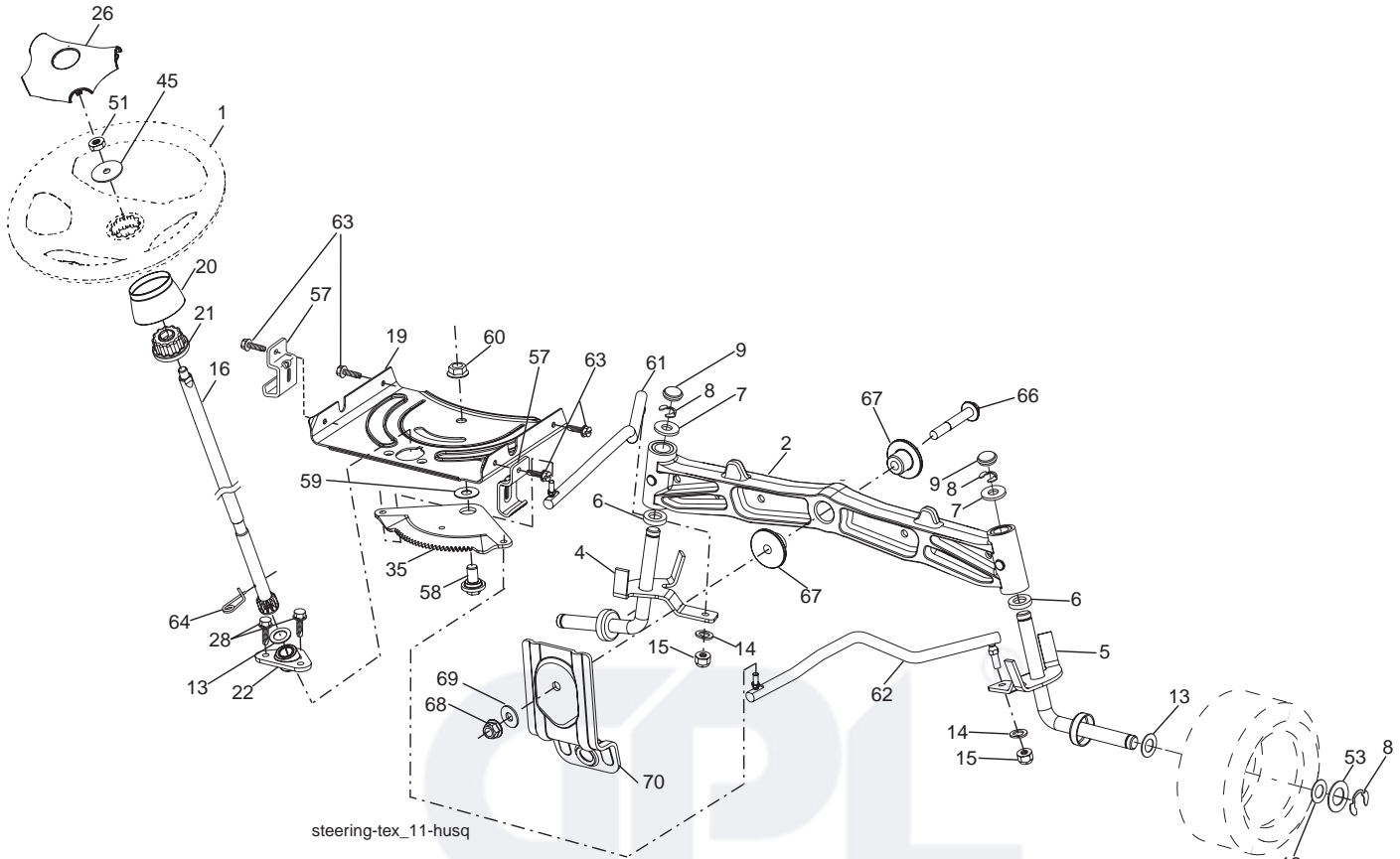

steering-tex_11-husq

KEY NO.	PART NO.	DESCRIPTION
1	532 19 46-37	Wheel, Steering
2	532 19 59-68	Axle Asm., Front
4	532 40 30-87	Spindle Asm., LH
5	532 40 30-88	Spindle Asm., RH
6	532 12 49-31	Bearing, Race Thrust Hardened
7	532 12 17-48	Washer 25/32 x 1-5/8 x 16 Ga.
8	812 00 00-29	Ring, Klip #T5304-75
9	532 12 12-32	Cap, Spindle
13	532 12 17-49	Washer 25/32 x 1-1/4 x 16 Ga.
14	810 04 06-00	Washer, Lock Hvy Hlcl Spr 3/8
15	873 54 06-00	Nut, Crown Lock 3/8-24 unf
16	532 19 47-46	Shaft Steering
19	532 19 47-29	Plate Steering
20	532 41 14-25	Boot Steering
21	532 18 67-37	Adapter, Wheel Steering
22	532 19 48-45	Bushing, Strg. Blk
26	532 19 36-52	Insert, Wheel Steering
28	817 00 06-12	Screw 3/8-16 x 3/4

KEY NO.	PART NO.	DESCRIPTION
35	532 19 47-32	Gear, Sector Plate
45	819 18 38-12	Washer 9/16 x 2-3/8 x 12 Ga.
51	873 94 08-00	Nut Hex Jam Toplock 1/2-20 unf
53	532 18 89-67	Washer Hardened .793 x 1.637 x .060
57	532 40 74-65	Bracket Upstop
58	532 19 47-47	Bolt Shoulder Sector Pivot CFM
59	532 19 47-48	Washer Thrust Sector Steering
60	873 97 10-00	Nut Flange Lock 5/8-11
61	532 19 47-40	Draglink, LH
62	532 19 47-41	Draglink, RH
63	817 00 05-12	Screw 5/16-18 x 3/4
64	532 19 98-49	Retainer Clip Spring Steering
66	871 02 07-48	Bolt Hex Fghd 7/16-14 x 3 Serr
67	532 19 47-37	Bushing PM Front Axle
68	873 90 07-00	Nut Lock Flange 7/16-14 Gr. 5
69	532 19 91-62	Washer 1.5 x .505 x .118
70	532 19 61-97	Bracket Deck Susp. Front

NOTE: All component dimensions given in U.S. inches
1 inch = 25.4 mm

TRACTOR - MODEL NO. LT2218A2 (96041003900), PRODUCT NO. 960 41 00-39 SEAT ASSEMBLY

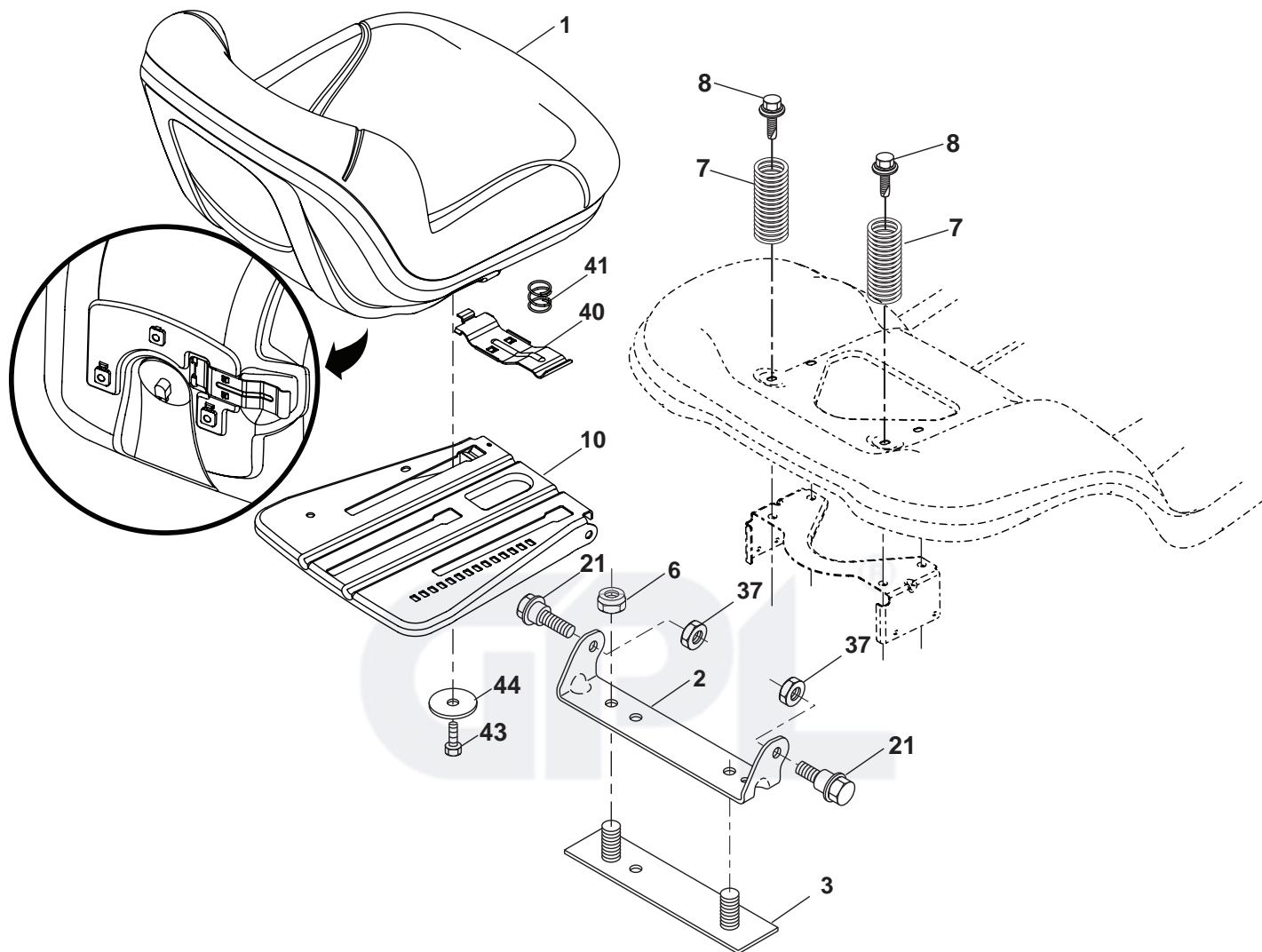

seat-tex_7-vgt

KEY NO.	PART NO.	DESCRIPTION
1	532 40 66-25	Seat
2	532 18 01-66	Bracket Pivot Fender
3	532 14 06-75	Strap, Asm Fender
6	873 80 06-00	Nut, Lock W/Ins. 3/8-16 unc
7	532 12 41-81	Spring, Seat Cprsn
8	532 17 18-77	Bolt 5/16-18 unc x 3/4 w/Sems
10	532 19 69-77	Pan, Seat

KEY NO.	PART NO.	DESCRIPTION
21	532 17 18-52	Bolt, Shoulder 5/16-18
37	873 80 05-00	Nut, Lock 5/16-18 unc
40	532 19 76-61	Handle Slide Seat
41	532 19 82-00	Spring Latch Seat
43	874 76 06-12	Bolt 3/8-16 x 3/4
44	819 13 38-12	Washer 13/32 x 2-3/8 x 12 Ga.

NOTE: All component dimensions given in U.S. inches
1 inch = 25.4 mm

**TRACTOR - MODEL NO. LT2218A2 (96041003900), PRODUCT NO. 960 41 00-39
MOWER LIFT**

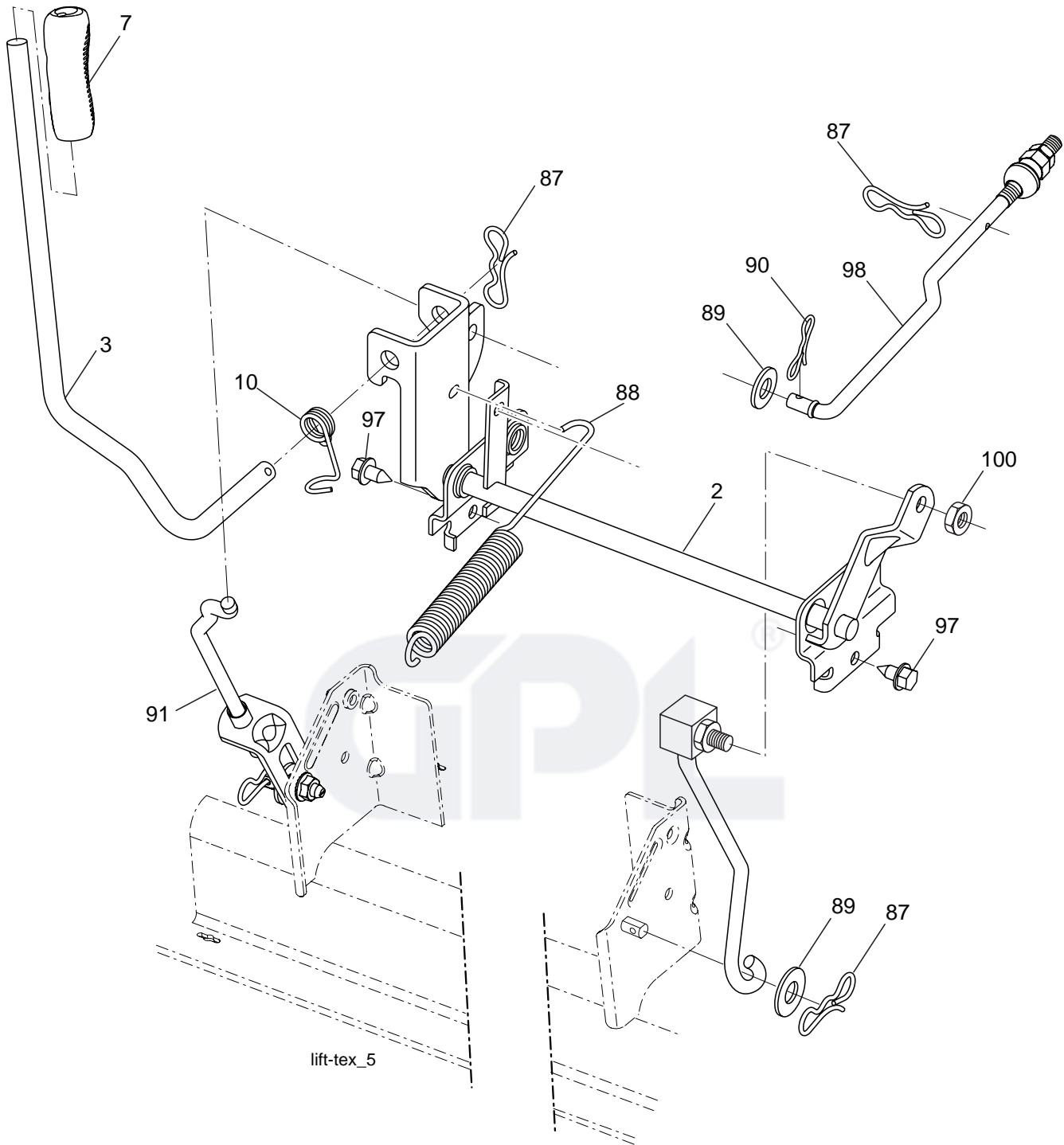

lift-tex_5

KEY NO.	PART NO.	DESCRIPTION
2	532 19 52-23	Shaft Asm., Lift
3	532 19 52-30	Lever Asm., Lift Rh
7	532 41 15-55	Grip, Lever
10	532 19 63-14	Spring Torsion
87	532 19 42-09	Pin Cotter 7/16 Bow Tie Lock
88	532 19 53-04	Spring Lift Assist

KEY NO.	PART NO.	DESCRIPTION
89	819 19 19-12	Washer Clear Zinc
90	532 19 42-08	Pin Cotter 5/16 Bow Tie Lock
91	532 19 51-81	Link Lift Susp Mower Rear
97	817 06 06-12	Screw 3/8-16 x .75 Smgml Tap/R.Z
98	532 19 52-70	Link Lift Susp. Front Mower
100	873 93 06-00	Nut Lock 3/8-16 unc

NOTE: All component dimensions given in U.S. inches
1 inch = 25.4 mm