

LT2223 CMA2

Spare parts
Ersatzteile
Pièces détachées
Reserve onderdelen
Repuestos
Reservdelar

GPL®

ILLUSTRATED PARTS LIST

MFG. ID NO. 96061024200

CUSTOMER CATALOG NO. LT2223CMA2

PRODUCT NO. 960 61 02-42

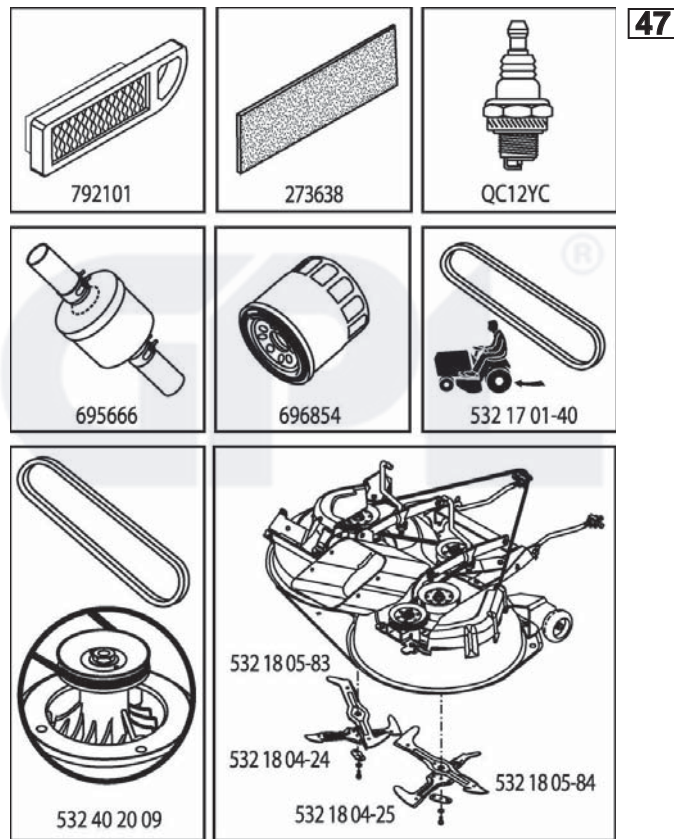

408674

**TRACTOR -- MODEL NO. LT2223CMA2 (96061024200), PRODUCT NO. 960 61 02-42
DECALS 27**

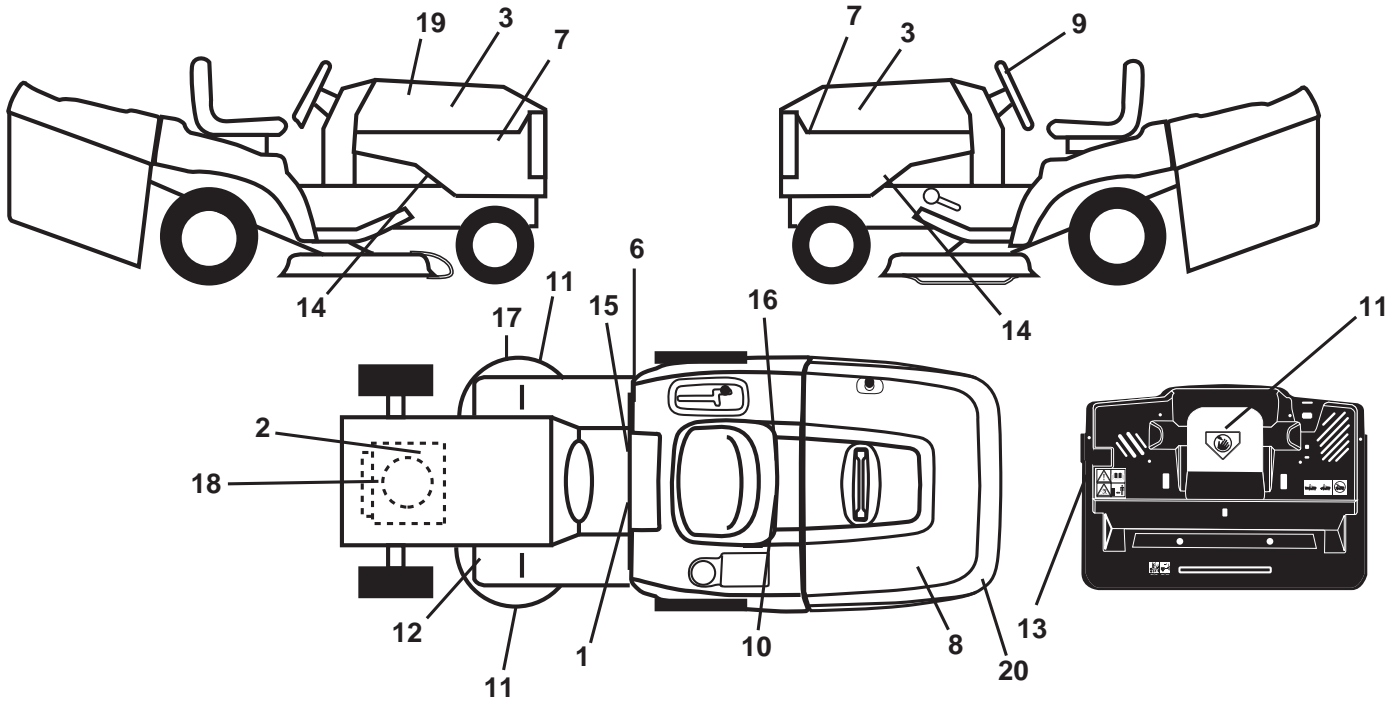

KEY NO.	PART NO.	DESCRIPTION	KEY NO.	PART NO.	DESCRIPTION
1	532 40 03-89	Decal, Warning Syms. CE	15	532 14 08-37	Decal, Saddle Brake Parking
2	532 19 68-41	Decal, Warning Eng. Sym.	16	532 16 69-60	Decal, Bypass Fender CRD
3	532 43 31-31	Decal, Hood RH/LH	17	532 16 62-86	Decal, Hex Belt Sch CRD
6	532 18 04-32	Decal, 100 DBA/CE	18	532 40 91-53	Decal, Engine H. P.
7	532 42 29-94	Decal, Panel Side	19	532 40 86-74	Decal, Replacement
8	532 18 39-31	Decal, Bagger	20	532 18 39-30	Decal, Cover/Bolt
9	532 42 26-85	Decal, Ins Strg Whl	--	532 18 10-91	Pad Footrest LH
10	532 14 50-05	Decal, Bat Dan/Poi P/L Sym Wpn	--	532 18 10-90	Pad Footrest RH
11	532 18 21-66	Decal, Mower Cut Finger Symbol	--	532 40 84-71	Manual Operator's (Euro)
12	532 15 97-37	Decal, Brake/Clutch Symbol Lt	--	532 40 84-72	Manual Operator's (Scan)
13	532 18 04-35	Decal, Rear Plate CRD	--	532 40 84-73	Manual Operator's (E-Bloc)
14	532 15 97-36	Decal, Chassis Hot Muffler	--	532 40 84-74	Manual Operator's (Baltic)

WHEELS & TIRES

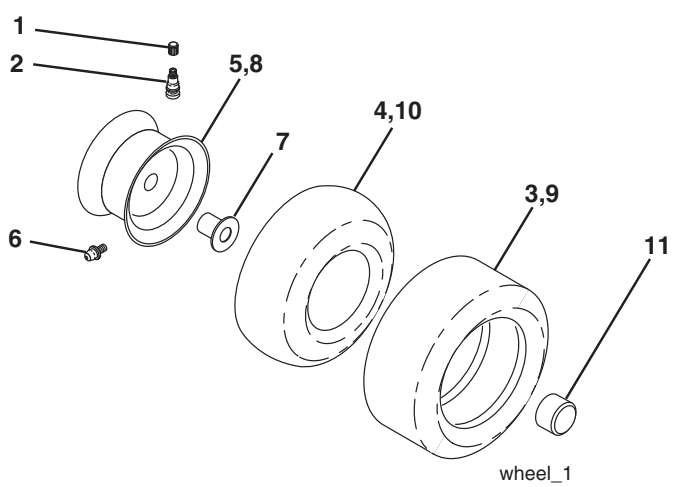

KEY NO.	PART NO.	DESCRIPTION
1	532 05 91-92	Cap Valve Tire
2	532 06 51-39	Stem Valve
3	532 10 62-22	Tire F Ts 15 x 6 0 - 6 Service
4	532 05 99-04	Tube Inner Front #35060
5	532 13 83-36	Rim Asm 6" Front Silver Service
6	532 12 49-57	Fitting Grease
7	532 12 49-59	Bearing Flange
8	532 13 83-37	Rim Asm 8" Rear Silver Service
9	532 12 20-82	Tire R Ts 20 x 10-8 Service
10	532 12 49-26	Tube Rear 9 5 x 8 Service
11	532 17 50-39	Cap Axle Blk 1 50 x 1 00
--	532 14 43-34	Sealant, Tire (10 oz. tube)

NOTE: All component dimensions given in U.S. inches
1 inch = 25.4 mm

TRACTOR -- MODEL NO. LT2223CMA2 (96061024200), PRODUCT NO. 960 61 02-42

SCHEMATIC **38**

SCH05

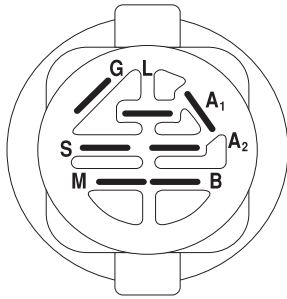
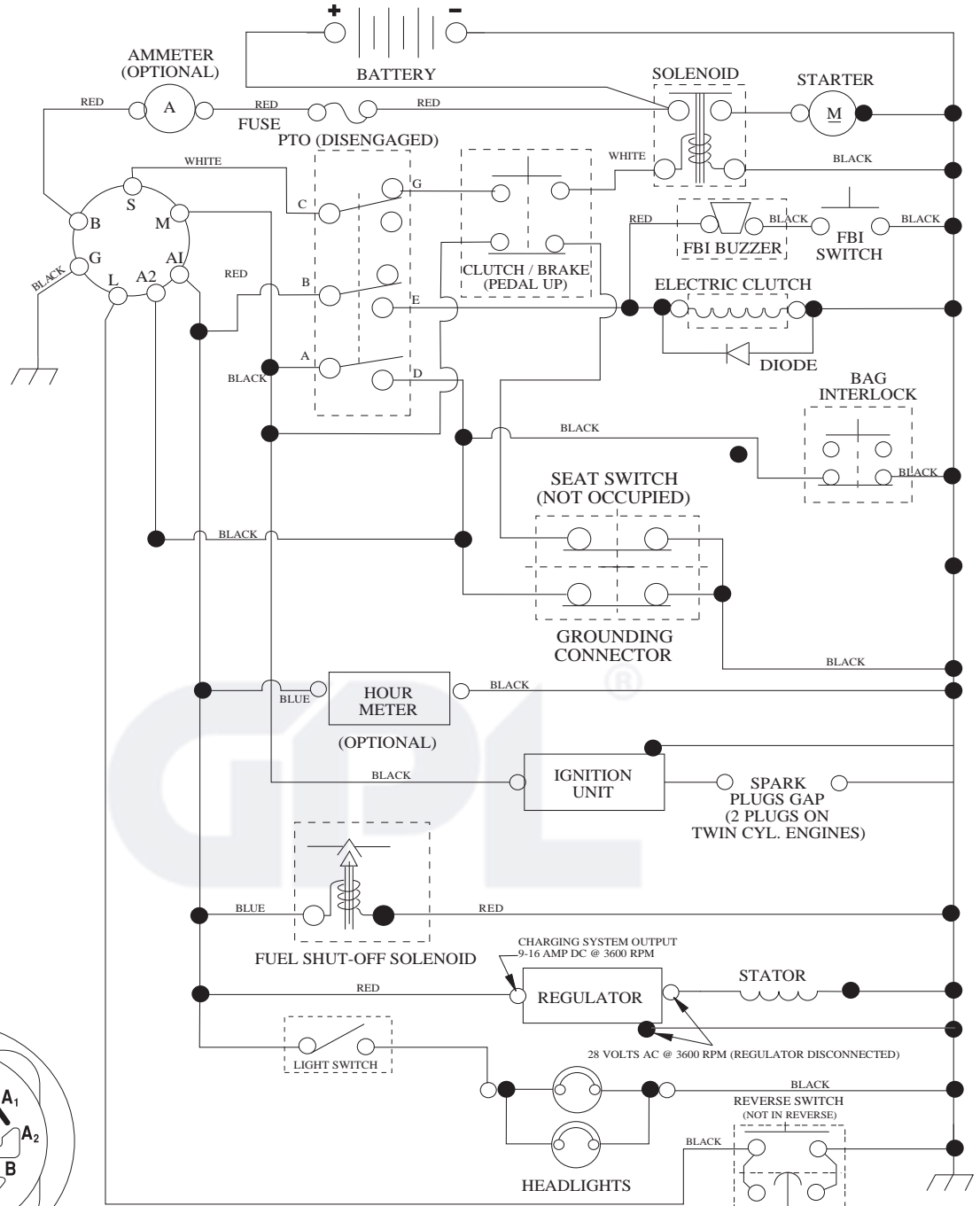

IGNITION SWITCH

POSITION	CIRCUIT	"MAKE"
OFF	M+G+A1	
RUN/OVERRIDE	B+A1	
RUN	B+A1	L+A2
START	B + S + A1	

WIRING INSULATED CLIPS
NOTE: IF WIRING INSULATED CLIPS WERE REMOVED FOR SERVICING OF UNIT, THEY SHOULD BE RE-INSTALLED TO PROPERLY SECURE YOUR WIRING.

03048

PTO SWITCH	
POSITION	CIRCUIT
OFF	C + G, B + H
ON	C + F, B + E, A + D

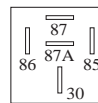

RELAY

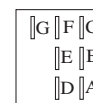

NON-REMOVABLE CONNECTIONS

REMOVABLE CONNECTIONS

TRACTOR -- MODEL NO. LT2223CMA2 (96061024200), PRODUCT NO. 960 61 02-42
 ELECTRICAL **32**

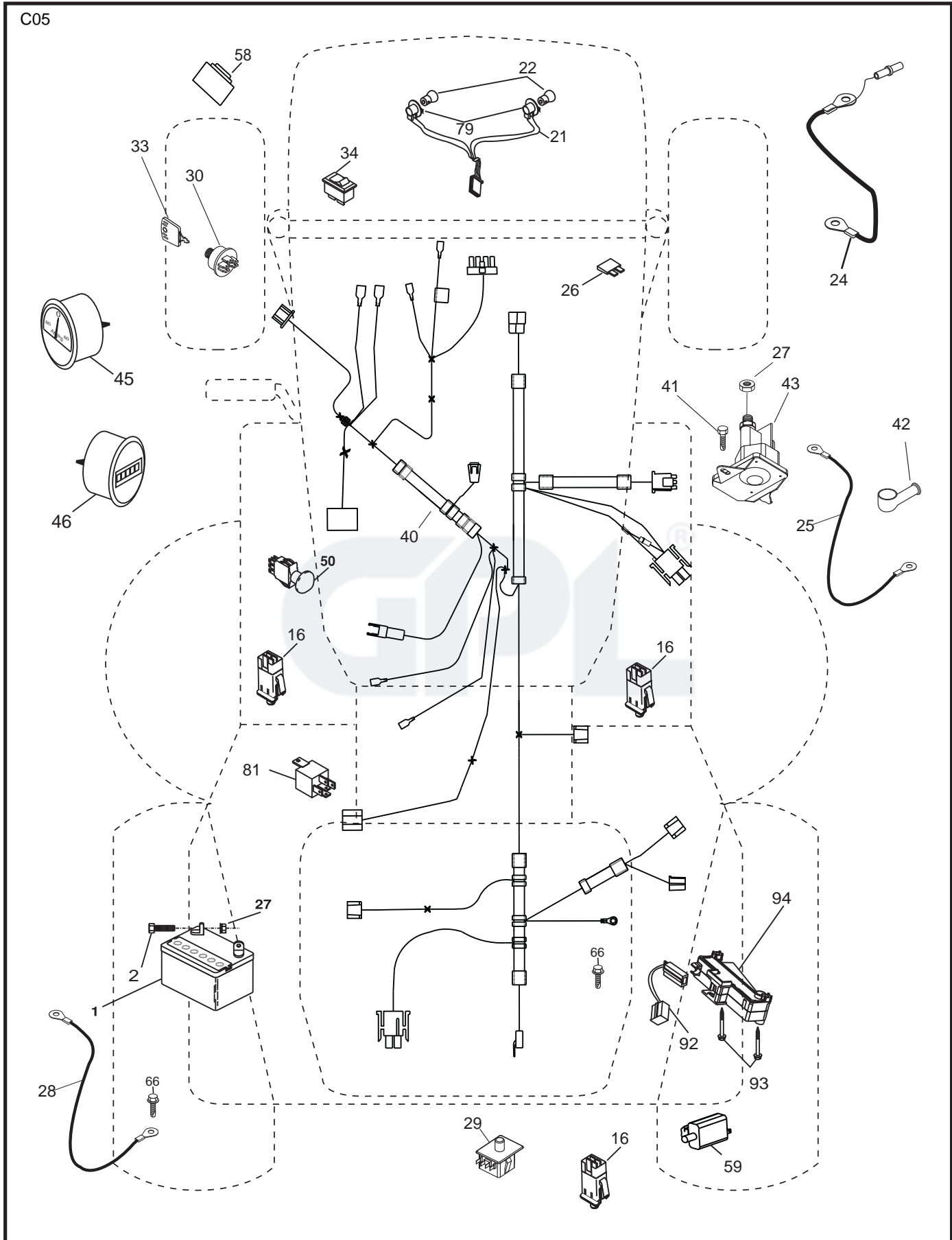

**TRACTOR -- MODEL NO. LT2223CMA2 (96061024200), PRODUCT NO. 960 61 02-42
ELECTRICAL 32**

KEY NO.	PART NO.	DESCRIPTION
1	532 16 34-65	Battery
2	874 76 04-12	Bolt Hex Hd 1/4-20 unc x 3/4
16	532 17 61-38	Switch Interlock Push-In
21	532 17 56-88	Harness Asm Light w/4152J
22	532 00 41-52	Bulb Light #1156
24	532 42 12-99	Cable Starter 6 Ga. 11" Red
25	532 16 59-87	Cable Battery
26	532 17 51-58	Fuse 20 Amp
27	873 51 04-00	Nut Keps Hex 1/4-20 unc
28	532 12 77-25	Cable Ground 6 Ga. 18" Black
29	532 19 27-49	Switch Seat
30	532 19 33-50	Switch Ignition
33	532 41 19-35	Key/Chain
34	532 11 07-12	Switch 10 x 3/4 Single Lead-Hex
40	532 19 74-39	Harness Ign Crd Elect
41	871 11 04-08	Bolt Hex Fin 1/4-20 unc x 1/2
42	532 13 15-63	Cover Terminal Red
43	532 19 25-07	Solenoid
45	532 42 29-43	Ammeter Round
46	532 42 29-44	Meter Hour
50	532 17 46-51	Switch PTO
58	532 16 94-19	Buzzer Crd
59	532 18 03-79	Switch FBI CRD
66	817 49 06-08	Screw Thdrol 3/8-16 x 1/2 Ty-Tt
79	532 17 52-42	Socket Asm. Bulb Twistlock
81	532 10 97-48	Relay Asm
92	532 19 66-15	Harness Pigtail Console
93	532 19 25-40	Screw Plastite 10-14 x 2.0
94	532 19 18-34	Module Reverse ROS

NOTE: All component dimensions given in U.S. inches.
1 inch = 25.4 mm.

**TRACTOR -- MODEL NO. LT2223CMA2 (96061024200), PRODUCT NO. 960 61 02-42
CHASSIS AND ENCLOSURES 39**

KEY NO.	PART NO.	DESCRIPTION	KEY NO.	PART NO.	DESCRIPTION
1	532 17 46-20	Chassis	154	532 18 39-25	Bracket, RH Dash
2	532 18 03-84	Drawbar	155	532 18 39-26	Bracket, LH Dash
3	817 06 06-12	Screw 3/8-16 x 3/4	161	532 16 46-55	Bumper Extrusion
6	532 18 44-19	Saddle	162	532 18 03-82	Bracket Exten Chassis LH CRD
8	532 12 64-71	Clip Insulator 13/32 Mtg. Hole	163	532 18 03-83	Bracket Exten Chassis RH CRD
9	532 19 49-28	Dash	164	532 16 56-05	Support Battery CRD
10	872 14 06-08	Bolt, Carriage 3/8-16 x 1	165	532 18 13-56	Cover Battery
11	532 16 72-03	Panel, Dash, L.H.	170	532 19 94-88	Backplate CRD
13	532 17 82-98	Panel, Asm. Dash R.H.	171	872 14 06-20	Bolt Rdhd Sqnk 3/8-16 x 2-1/2 Gr. 5
15	874 18 05-12	Screw Machine TRHD 5/16-18 unc x 3/4	172	819 13 20-16	Washer 13/32 x 1-1/4 x 16 Ga.
16	873 51 05-00	Nut Keps 5/16-18 unc	173	873 51 06-00	Nut, Keps Hex 3/8-16 unc
17	532 18 13-51	Hood	175	532 18 82-03	Guard Trap
24	874 78 06-16	Bolt	179	532 18 82-02	Rod Pivot FBI CRD
25	819 13 13-12	Washer 13/32 x 13/16 x 12 Ga.	184	532 17 46-62	Bracket Actuator Bagger CRD
26	873 80 06-00	Nut	185	532 18 11-01	Knob Rod Brake Parking
28	532 42 07-24	Grille	186	532 16 07-93	Latch Asm Mulch/Bagger
29	532 16 18-40	Lens, Grille	187	532 12 50-04	Nut Weld
30	532 19 73-44	Fender	188	819 06 12-16	Washer #10
31	532 16 51-56	Bracket, Fender Support	189	810 07 10-00	Washer Lock #10
33	532 18 11-93	Footrest, L.H.	190	871 08 10-10	Screw Pan Hd Phillip 10-24 x 5/8
34	532 18 11-94	Footrest, R.H.	198	532 16 89-37	Nut, Push
35	872 11 06-06	Bolt	205	817 49 06-08	Screw Thdrol 3/8-16 x 1/2
37	817 49 05-08	Screw Thdrol 5/16-18 x 1/2 TYT	207	817 67 05-08	Screw Thdrol 5/16-18 x 1/2
38	532 18 17-48	Bracket Asm Pivot Mower Rear	209	817 00 06-12	Screw Hex Wsh Thdrol 3/8-16
54	532 19 25-12	Screw Hex WsHd 10-32 x 5/8	256	532 18 13-61	Cover Fender Rack CRD
58	532 17 53-51	Duct Air Engine	265	532 18 57-04	Seal RH Side Bagger
64	532 19 93-95	Lower dash	266	532 18 57-03	Seal LH Side Bagger
69	532 14 24-32	Screw Hex Wsh	278	532 41 63-58	Screw #10 x 0.750 BOS Thread
89	532 19 73-66	Console			
145	532 40 91-67	Rod Pivot Chassis/Hood			

NOTE: All component dimensions given in U.S. inches.
1 inch = 25.4 mm.

**TRACTOR -- MODEL NO. LT2223CMA2 (96061024200), PRODUCT NO. 960 61 02-42
DRIVE 40**

KEY NO.	PART NO.	DESCRIPTION	KEY NO.	PART NO.	DESCRIPTION
1	-----	Transaxle Hydro Gear 321-0510	95	532 17 00-15	Control Asm Bypass Hydro
8	532 19 27-06	Rod, Shift Fender Adjust Lt	96	532 12 47-88	Spring, Retainer 1"
9	532 19 81-43	Clutch Ele	112	819 09 12-10	Washer 9/32 x 3/4 x 10 Ga.
10	876 02 04-16	Pin, Cotter 1/8 x 1	120	873 90 06-00	Nut Lock Flg. 3/8-16 unc
14	810 04 04-00	Washer, Lock Hvy Helical	150	532 16 58-50	Bushing, Bellcrank Grnd Dr
15	874 49 05-44	Bolt Hex FGHD 5/16-18 x Gr. 5	151	819 13 32-10	Washer 13/32 x 2 x 10 Ga.
16	873 80 05-00	Nut, Lock Hex w/Ins 5/16-18 unc	156	532 16 60-02	Washer Srrted 5/16 ID x 1.125
17	810 04 07-00	Washer Lock Hvy Hlcl 7/16	158	532 16 55-89	Bracket Shift Mount
19	873 80 06-00	Nut Lock Hex w/Insert 3/8-16 unc	159	532 18 39-00	Hub Tapered Flange Shift Lt
20	532 17 39-37	Bolt, Hex 7/16-20 x 4	161	872 14 04-06	Bolt Rdhd Sqnk 1/4-20 x 3/4 Gr 5
21	532 13 05-64	Knob Deluxe	162	873 68 04-00	Nut Crownlock 1/4-20 unc
22	532 17 56-07	Rod, Brake	163	874 78 04-16	Bolt Hex Fin 1/4-20 unc x 1 Gr 5
24	873 35 06-00	Nut	165	532 16 56-23	Bracket Pivot Lever
25	532 19 20-36	Spring, Rod, Brake	166	817 49 05-10	Screw 5/16-18 x 5/8
27	876 02 04-12	Pin, Cotter 1/8 x 3/4	167	532 16 55-88	Bracket Support Shift CRD
28	532 17 57-65	Rod, Parking Brake	168	532 16 54-92	Bolt Shoulder 5/16-18 x .561
29	532 07 16-73	Cap, Parking Brake	169	532 16 55-80	Plate Fastening Lt
30	532 16 95-92	Bracket, Mfg. Transaxle	171	817 49 06-08	Screw Thdrol 3/8-16 x 1/2 Ty-Tt
34	532 17 55-78	Shaft, Asm Pedal Foot CRD	172	532 17 02-71	Shaft Asm Shifter Frt CRD
35	532 12 01-83	Bearing, Nylon	177	532 16 59-32	Keeper Flat Idler 3.06" CRD
36	819 21 16-16	Washer 21/32 x 1 x 16 Ga.	181	532 18 02-11	Bracket Idler Ground Drive CRD
37	532 12 49-63	Pin, Roll 3/16 x 1"	182	532 18 26-82	Keeper Belt 2.5" Od V-Idler CRD
38	532 16 59-36	Pulley Flat Composite 3.06"	183	532 19 95-32	Pulley V-Idler CRD
39	874 76 06-44	Bolt Fin Hex 3/8-16 unc x 2-3/4	185	532 17 00-08	Link Shift
40	532 12 49-65	Spacer, Split 395 x 59 Bzp	186	532 16 56-14	Hub Tapered Round CRD
42	819 13 13-12	Washer 13/32 x 13/16 x 12 Ga.	187	817 58 05-20	Screw Thdrol 5/16-18 x 1.25
43	819 11 10-12	Washer 11/32 x 5/8 x 12 Ga.	197	532 16 96-13	Nyliner Snap-In 5/8
47	532 12 77-83	Pulley, Idler, V Groove Plasic	199	532 16 96-12	Bolt Shoulder 5/16-18 unc
48	532 15 44-07	Bellcrank Clutch Grnd Drv	200	872 14 05-08	Bolt RDHD SQNK 5/16-18 x 1
49	532 12 32-05	Retainer, Belt Style Spring	207	532 16 98-45	Washer Nylon Rear
50	872 11 06-12	Bolt Carr. Sh. 3/8-16 x 1-1/2 Gr. 5	214	532 17 56-09	Shaft Asm. Brake
51	873 68 06-00	Nut, Crownlock 3/8-16 unc	215	532 17 56-52	Rod Brake Hydro
52	873 6805-00	Nut Crownlock 5/16-18	243	532 19 07-36	Bracket Anti Rotation
53	532 19 96-52	Link, Clutch 7.66	252	819 13 16-16	Washer 13/32 x 1 x 16 Ga.
55	532 10 57-09	Spring, Return, Clutch	254	817 00 06-16	Screw 3/8-16 x 1
56	817 06 06-20	Screw 3/8-16 x 1-1/4	255	532 17 56-08	Brace Shaft Brake Mtg.
57	532 17 01-40	V-Belt Kev 112" 0650 CRD	258	532 17 80-62	Clip Retainer
62	532 12 48-72	Cover, Pedal	259	532 18 02-12	Bracket Pulley
63	532 18 03-97	Pulley, Engine	261	532 13 14-94	Pulley Idler Flat
65	532 12 61-97	Washer	262	872 11 06-22	Bolt Rdhd 3/8-16 unc x 2-3/4 Gr. 5
66	532 15 47-78	Keeper, Belt Engine F-Proof	263	817 00 06-12	Screw Hx Wsh Thdrol 3/8-16 x 3/4
71	532 16 91-83	Strap, Torque, LH	264	532 19 76-07	Bracket Idler Chassis
73	532 16 91-82	Strap, Torque, RH	266	532 18 20-61	Shield Idler
74	532 13 70-57	Spacer, Split	279	872 11 06-16	Bolt Rdhd Sqnk 3/8-16 unc x 2
75	532 12 17-49	Washer 25/32 x 1-1/4 x 16 Ga.	292	532 40 02-71	Spacer Noram
76	812 00 00-01	Ring, E	295	532 17 91-14	Pulley Idler Composite
77	532 12 35-83	Key, Square			
78	532 12 17-48	Washer 25/32 x 1-5/8 x 16 Ga.			
81	532 17 00-06	Asm, Shaft			
82	532 16 57-11	Spring, Torsion			
83	819 17 12-16	Washer 17/32 x 3/4 x 16 Ga.			
84	532 17 00-07	Link, Transaxle			

NOTE: All component dimensions given in U.S. inches
1 inch = 25.4 mm

**TRACTOR -- MODEL NO. LT2223CMA2 (96061024200), PRODUCT NO. 960 61 02-42
ENGINE 24**

KEY NO.	PART NO.	DESCRIPTION
1	532 17 83-85	Control Throttle
2	532 41 63-58	Screw #10 x 0.750 BOS Thread
3	-----	Engine Briggs 445577
4	532 14 97-23	Muffler Twin Lo-Twin
5	532 16 05-89	Pipe Exhaust RH
6	532 15 99-55	Pipe Exhaust LH
8	532 17 18-77	Bolt 5/16-18 unc x 3/4 w/Sems
10	532 14 66-29	Shield Heat Muffler
13	532 16 53-91	Gasket Muffler
14	532 14 84-56	Tube Drain Oil Easy
17	817 06 06-20	Screw, Thdrol 3/8-16 x 1-1/4
23	532 16 98-37	Shield Brn/Dbr Guard
25	532 19 15-96	Choke Control
29	532 13 71-80	Kit Spark Arrester (Flat Scrn)
31	532 40 75-51	Tank Fuel
32	532 19 77-25	Cap Asm Fuel Top
33	532 12 34-87	Clamp Hose Blk
37	532 13 70-40	Line Fuel
38	532 18 16-54	Plug Drain Oil Easy
44	817 67 04-12	Screw Hexwsh Thdrol 1/4-20 x 3/4
45	817 00 06-12	Screw Hexwsh Thdrol 3/8-16 x 3/4
46	819 09 14-16	Washer 9/32 x 7/8 x 16 Ga.
72	532 18 39-06	Screw 5/16-18 x 1
81	873 51 04-00	Nut Keps Hex 1/4-20

NOTE: All component dimensions given in U.S. inches
1 inch = 25.4 mm

Engine Power Rating Information

The gross power rating for individual gas engine models is labeled in accordance with SAE (Society of Automotive Engineers) code J1940 (Small Engine Power & Torque Rating Procedure), and rating performance has been obtained and corrected in accordance with SAE J1995 (Revision 2002-05). Torque values are derived at 3060 RPM; horsepower values are derived at 3600 RPM. Actual gross engine power will be lower and is affected by, among other things, ambient operating conditions and engine-to-engine variability. Given both the wide array of products on which engines are placed and the variety of environmental issues applicable to operating the equipment, the gas engine will not develop the rated gross power when used in a given piece of power equipment (actual "on-site" or net power). This difference is due to a variety of factors including, but not limited to, accessories (air cleaner, exhaust, charging, cooling, carburetor, fuel pump, etc.), application limitations, ambient operating conditions (temperature, humidity, altitude), and engine-to-engine variability. Due to manufacturing and capacity limitations, Briggs & Stratton may substitute an engine of higher rated power for this Series engine.

TRACTOR -- MODEL NO. LT2223CMA2 (96061024200), PRODUCT NO. 960 61 02-42
STEERING ASSEMBLY [41]

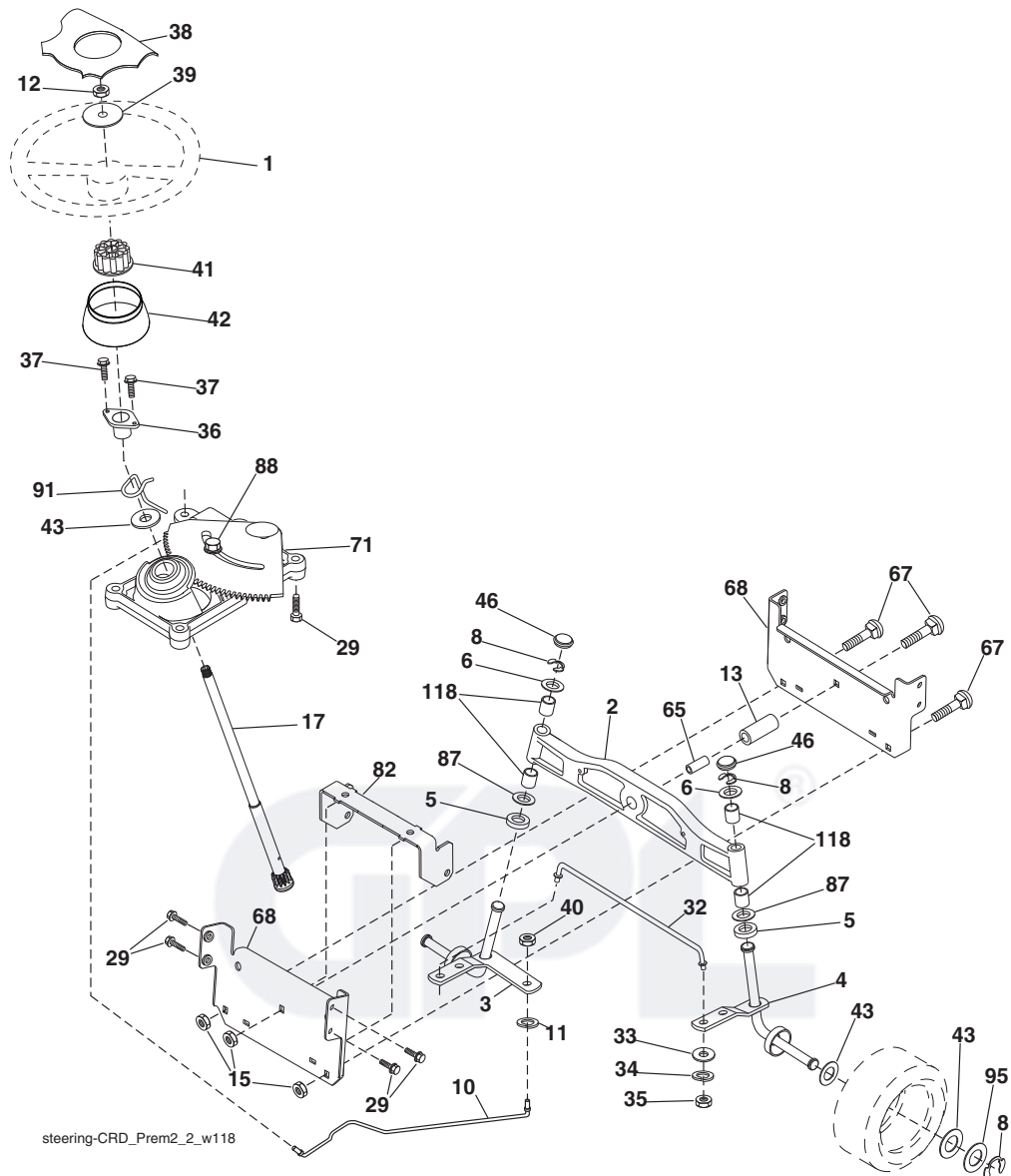

steering-CRD_Prem2_2_w118

KEY NO.	PART NO.	DESCRIPTION	KEY NO.	PART NO.	DESCRIPTION
1	532 42 41-46	Steering Wheel	38	532 42 41-47	Cap Wheel Steering
2	532 19 35-42	Front Axle Assembly	39	819 18 38-12	Washer 9/16 ID x 2-3/8 OD 12 Ga.
3	532 16 98-40	Spindle Assembly, L.H.	40	873 54 06-00	Nut Crownlock 3/8-24
4	532 16 98-39	Spindle Assembly, R.H.	41	532 18 67-37	Adaptor, Steering Wheel
5	532 12 49-31	Bearing, Race, Thrust, Hardened	42	532 41 14-25	Boot, Steering Dash
6	532 12 17-48	Washer 25/32 x 1-5/8 x 16 Ga.	43	532 12 17-49	Washer 25/32 x 1-1/4 x 16 Ga.
8	812 00 00-29	Ring, Klip	46	532 12 12-32	Cap, Spindle
10	532 17 51-21	Link, Drag	65	532 41 47-36	Spacer Axle
11	810 04 06-00	Washer, Lock	67	872 11 06-18	Bolt Rdhd Sq 3/8-16 x 2-1/4
12	873 94 08-00	Nut Hex Jam Toplock 1/2-20 unf	68	532 16 98-27	Brace Axle
13	532 13 65-18	Spacer Axle	71	532 17 51-46	Steering Asm.
15	532 14 52-12	Nut Hex Flange Lock	82	532 19 99-78	Bracket Susp. Chassis Front
17	532 17 78-83	Shaft Assembly, Steering	87	532 17 39-66	Washer Flat .781 x 1-1/2 x .14
29	817 00 06-12	Screw 3/8-16 x 3/4	88	532 17 51-18	Bolt Shoulder 7/16-20 unc
32	532 17 18-88	Rod, Tie	91	532 17 55-53	Clip Steering
33	819 11 12-16	Washer 11/32 x 3/4 x 16 Ga.	95	532 18 89-67	Washer
34	810 04 05-00	Washer Lock Hvy Hlcl Spr 5/16	118	532 40 60-13	Bushing
35	873 54 05-00	Crownlock Nut 5/16-24 unf			
36	532 15 51-05	Bushing, Steering			
37	532 15 29-27	Screw TT #10-32 x 5 x 3/8 Flange			

NOTE: All component dimensions given in U.S. inches.
 1 inch = 25.4 mm.

**TRACTOR -- MODEL NO. LT2223CMA2 (96061024200), PRODUCT NO. 960 61 02-42
SEAT ASSEMBLY 42**

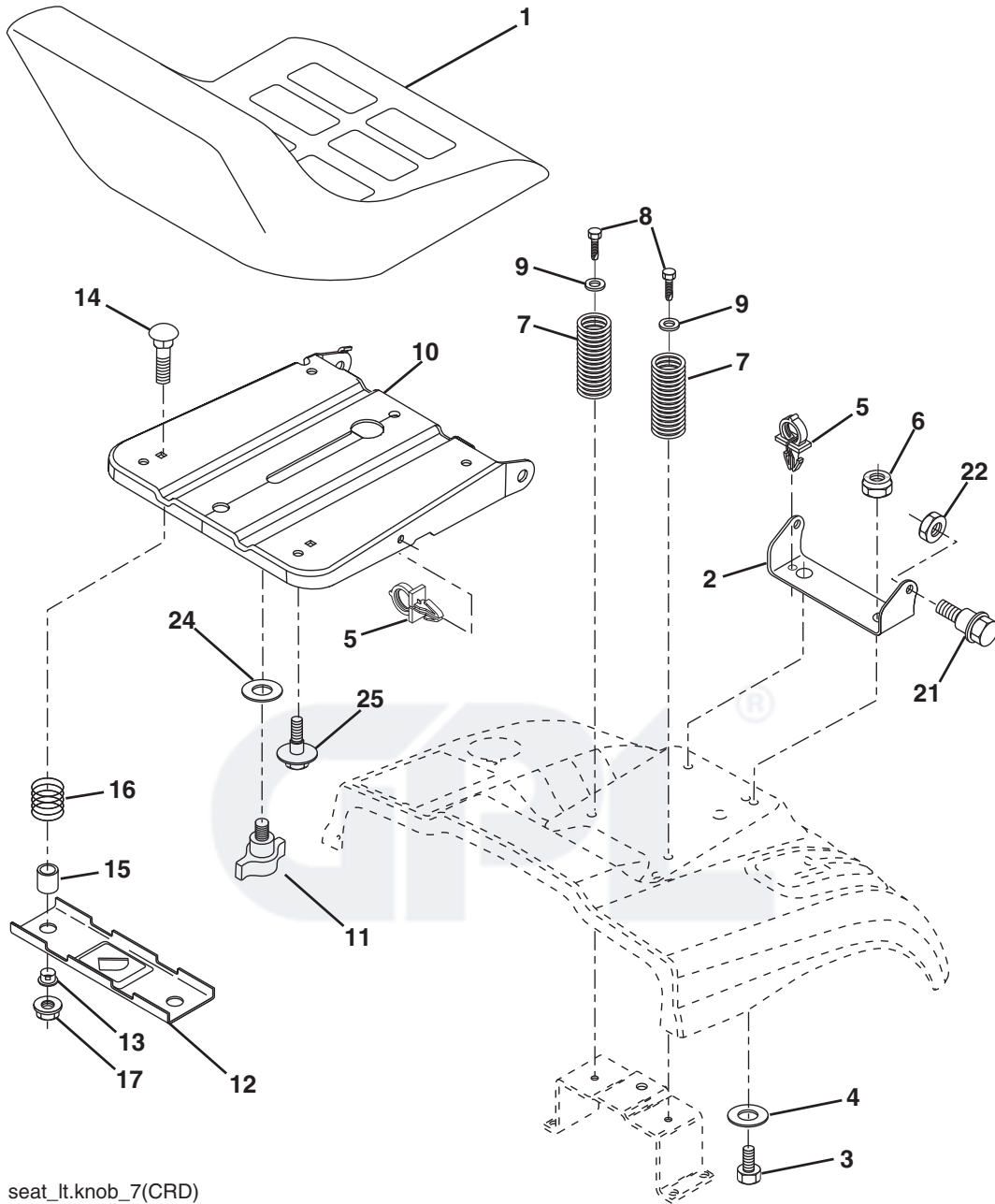

seat_lt.knob_7(CRD)

KEY NO.	PART NO.	DESCRIPTION	KEY NO.	PART NO.	DESCRIPTION
1	532 40 10-43	Seat	13	532 12 12-48	Bushing Snap Blk Nyl 50 Id
2	532 14 05-51	Bracket Pivot	14	872 05 04-12	Bolt Rdhd Sht Nk 1/4-20 x 1-1/2
3	871 11 06-16	Bolt Fin Hex 3/8-16 x 1	15	532 12 12-49	Spacer Split 28 x 88 Zinc
4	819 13 16-10	Washer flat 13/32 x 1 x 10 Ga.	16	532 12 37-40	Spring Cprsn
5	532 14 50-06	Clip Push In Hinged	17	532 12 39-76	Nut Lock 1/4 Lge Flg Gr 5 Zinc
6	873 80 06-00	Nut Lock Hex 3/8-16 unc	21	532 17 18-52	Bolt Shoulder 5/16-18 unc-2A
7	532 12 41-81	Spring Seat Cprsn 2 250 Blk Zi	22	873 80 05-00	Nut Hex Lock w/Ins 5/16-18
8	817 00 06-16	Screw 3/8-16 x 1-1/2	24	819 17 19-12	Washer 17/32 x 1-3/16 x 12 Ga.
9	819 13 16-14	Washer 13/32 x 1 x 14 Ga	25	532 12 70-18	Bolt Shoulder 5/16-18 x .62
10	532 19 55-30	Pan Seat			
11	532 16 63-69	Knob Seat Adj. Wingnut			
12	532 17 46-48	Bracket Pnt Mounting Switch			

NOTE: All component dimensions given in U.S. inches.
1 inch = 25.4 mm

TRACTOR -- MODEL NO. LT2223CMA2 (96061024200), PRODUCT NO. 960 61 02-42
 MOWER DECK 44

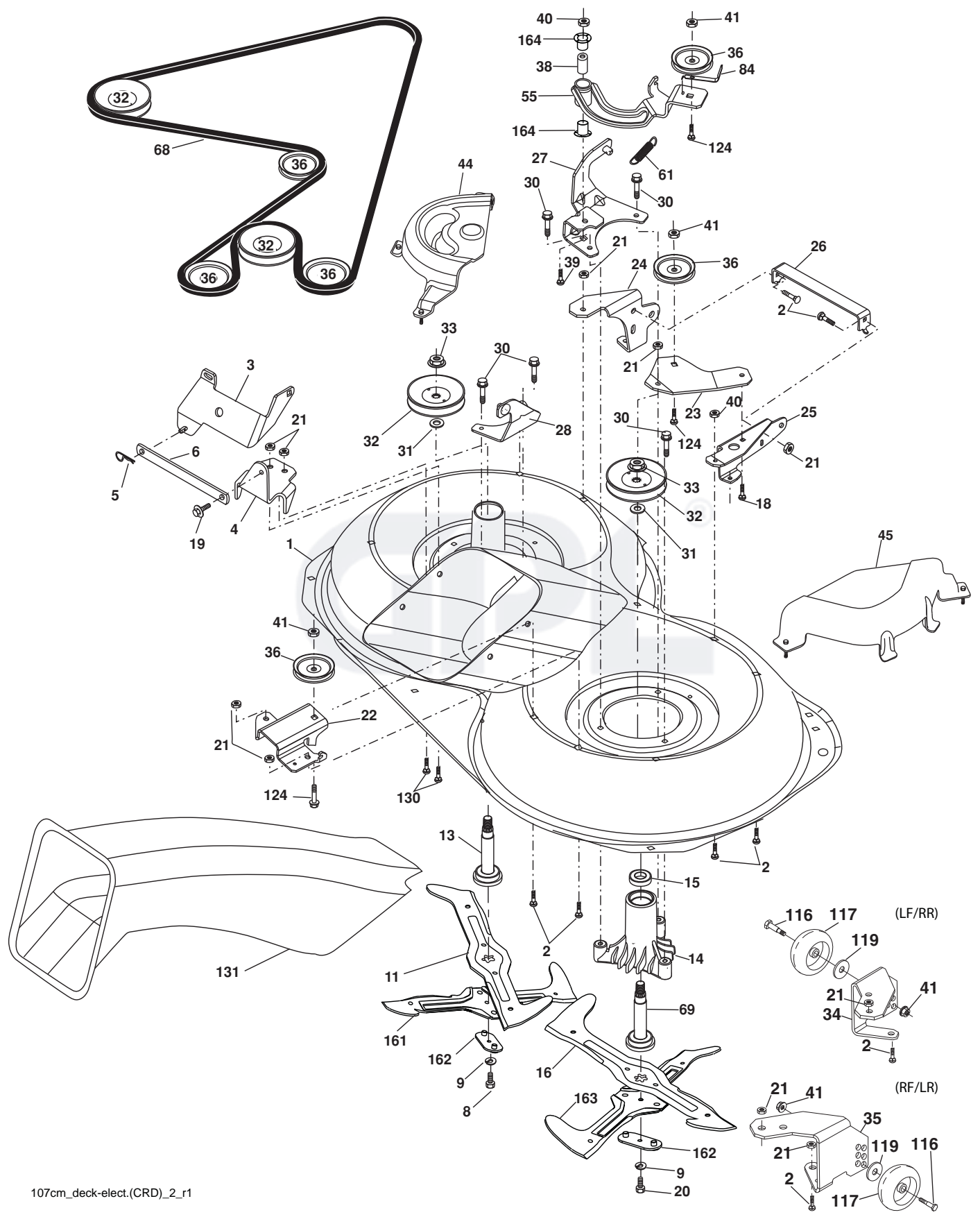

107cm_deck-elect.(CRD)_2_r1

**TRACTOR -- MODEL NO. LT2223CMA2 (96061024200), PRODUCT NO. 960 61 02-42
MOWER DECK 44**

KEY NO.	PART NO.	DESCRIPTION	KEY NO.	PART NO.	DESCRIPTION
1	532 16 91-60	Housing Asm. Mower 107 CRD	40	873 68 06-00	Nut Crownlock 3/8-16 unc
2	872 14 05-06	Bolt Rdhd Sqnk 5/16-18 unc x 3/4	41	873 90 06-00	Nut Flangelock 3/8-16 unc
3	532 43 18-64	Bracket Asm. S-Bar Chass 92 CRD	44	532 43 27-73	Cover Mandrel LH 107 CRD
4	532 16 91-67	Bracket Bar Sway Deck 107 CRD	45	532 43 27-72	Cover Mandrel RH 107 CRD
5	532 12 46-70	Retainer Spring	55	532 16 98-49	Arm Idler 107 CRD
6	532 16 55-57	Bar Sway CRD	61	532 19 94-87	Spring Tension Belt
8	532 18 17-12	Bolt 3/8-24 x 1.25 Gr. 8 Patched	68	532 40 20-09	Belt Drive
9	810 03 06-00	Washer Lock Hvy 3/8 Unplated	69	532 16 54-82	Shaft Asm w/Lwr Brg RH Thd CRD
11	532 18 05-83	Blade 3-1 LH 107 CRD	84	532 15 60-85	Keeper Belt Idler
13	532 13 76-45	Shaft Asm. w/Lower Bearing	116	532 19 34-06	Bolt Shoulder
14	532 12 87-74	Housing Mandrel Vented (Machd)	117	532 17 48-73	Wheel Gage Donut Wide
15	532 11 04-85	Bearing Ball Mandrel	119	819 13 20-12	Washer 13/32 x 1-1/4 x 12 Ga.
16	532 18 05-84	Blade 3-1 RH 107 CRD	124	872 11 06-12	Bolt Carr Sh 3/8-16 x 1-1/2 Gr. 5
18	872 11 06-06	Bolt RdHd Sqnk 3/8-16 x 3/4	130	872 11 05-06	Bolt Rdhd sqnk 5/16-18 unc x 3/4
19	532 13 28-27	Bolt Shoulder 5/16-18 Thd Form	131	532 16 56-61	Chute Bagger CRD 92cm
20	532 18 17-13	Bolt 3/8-24 x 1.25 Gr. 8 Ptch Lhthd	161	532 18 04-24	Blade Cross LH 107
21	873 68 05-00	Nut Crown Lock 5/16-18	162	532 18 08-78	Adapter Weldment Blade 107
22	532 16 91-65	Bracket Idler Sprt RR 107 CRD	163	532 18 04-25	Blade Cross RH 107
23	532 16 91-66	Bracket Idler Sprt RF 107 CRD	164	532 12 49-37	Bearing Col. Strg.
24	532 41 34-36	Bracket Suspension LH 107 CRD	---	532 18 18-57	Mandrel Assembly (Includes hous- ing, shaft assembly, and bear- ing only - pulley/nut/washer and blade bolt/washers not included)
25	532 40 01-05	Bracket Suspension RF 107 CRD	---	532 18 18-58	Mandrel Asm CRD LH Threads SVC
26	532 40 01-10	Brace Support Susp Frt CRD	--	532 40 03-25	Replacement Mower Complete
27	532 16 91-72	Bracket Asm. Susp RR 107 CRD			
28	532 16 91-68	Bracket Asm. Susp LR 107 CRD			
30	532 17 39-84	Screw Thd Rolling Hex			
31	532 18 76-90	Washer Spacer			
32	532 19 81-45	Mandrel Pulleys			
33	532 40 02-34	Nut Flg Top Lock			
34	532 40 01-03	Bracket Gauge Wheel LF/RR			
35	532 40 01-04	Bracket Gauge Wheel RF/LR			
36	532 14 67-63	Pulley Idler V-Groove Dim 4.25			
38	532 16 98-51	Spacer Hub Arm Idler 107 CRD			
39	872 11 06-22	Bolt Rdhd 3/8-16 unc x 2-3/4 Gr. 5			

NOTE: All component dimensions given in U.S. inches
1 inch = 25.4 mm

TRACTOR -- MODEL NO. LT2223CMA2 (96061024200), PRODUCT NO. 960 61 02-42
MOWER LIFT 45

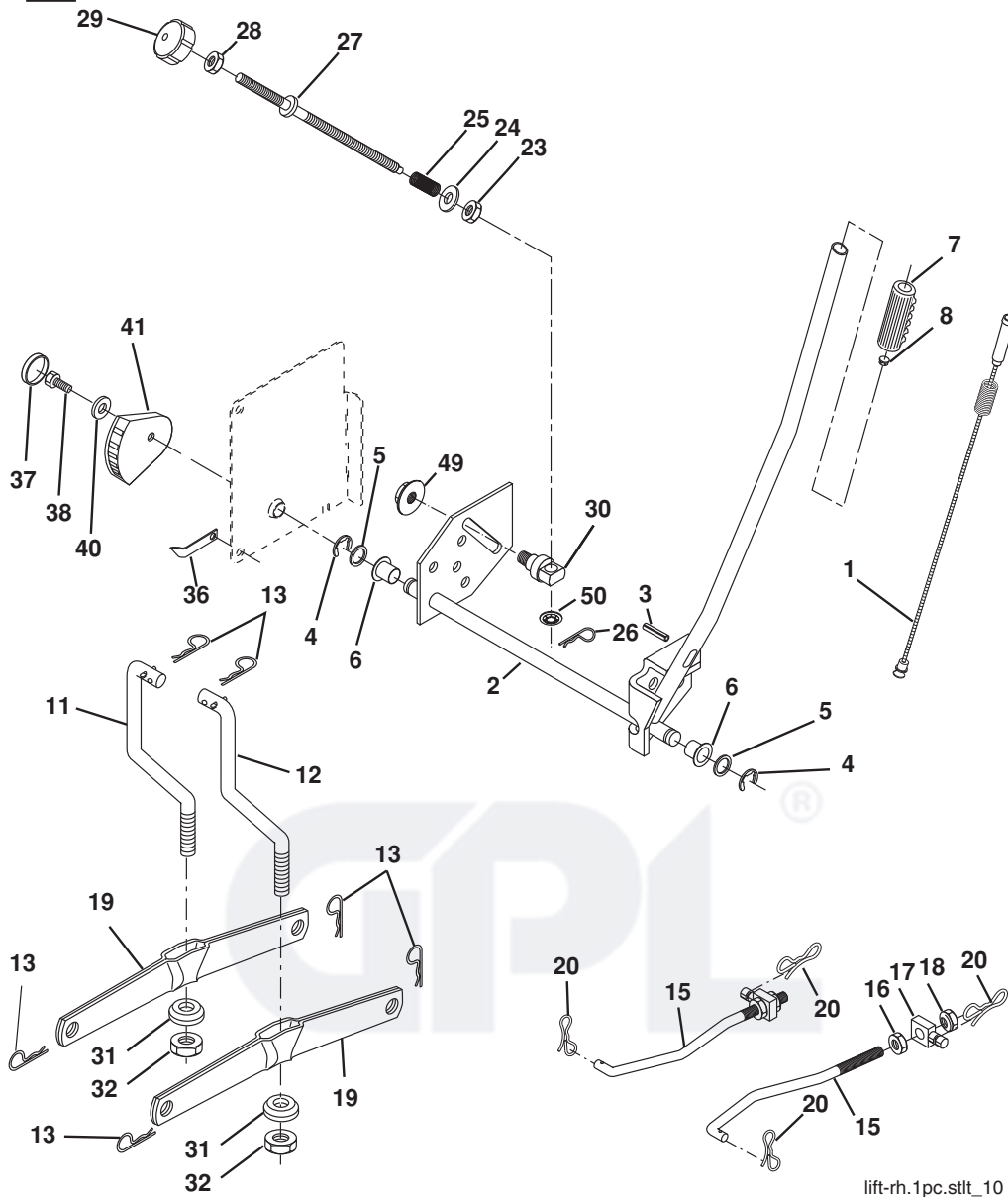

lift-rh.1pc.stlt_10

KEY NO.	PART NO.	DESCRIPTION
1	532 40 50-07	Plunger Asm. Lift LVR
2	532 19 80-70	Shaft Asm. Lift
3	532 18 88-22	Pin Groove
4	812 00 00-02	E Ring #5133-62
5	819 21 16-21	Washer 21/32 x 1 x 21 Ga.
6	532 12 01-83	Bearing Nylon
7	532 12 56-31	Grip Handle Fluted
8	532 12 45-26	Button Plunger Black
11	532 16 58-29	Link Asm Lift L.H.
12	532 16 58-31	Link Asm Lift R.H.
13	532 12 46-70	Retainer Spring
15	532 17 32-88	Link Front
16	873 35 08-00	Nut Jam Hex 1/2-13 unc
17	532 17 56-89	Trunnion Blk Zinc
18	873 80 08-00	Nut Lock W/Wsh 1/2-13 unc
19	532 13 98-68	Arm Suspension Mower
20	532 19 42-09	Pin Cotter 7/16 Bow Tie Lock
23	532 11 08-07	Nut Special
24	819 13 10-16	Washer 13/32 x 5/8 x 16 Ga.

KEY NO.	PART NO.	DESCRIPTION
25	532 16 40-24	Spring
26	532 16 94-84	Retainer Clip
27	532 16 45-43	Rod Adj Lift Zinc
28	873 35 06-00	Nut Hex Jam 3/8-16 unc
29	532 13 80-57	Knob Inf 3/8-16 unc Blk w/sym
30	532 15 02-33	Trunnion Infin Height
31	532 16 98-65	Bearing, Pvt. Lift.
32	873 54 06-00	Nut Crownlock 3/8-24
36	532 15 50-97	Pointer Height Indicator
37	532 12 39-35	Plug Hole Blk 1.485/1.515 Dia
38	817 06 05-16	Screw 5/16-18 x 1
40	819 11 24-10	Washer 11/32 x 1-1/2 x 10 Ga.
41	532 12 39-34	Scale Ind Height Blk
49	532 14 52-12	Nut hex Flange Lock
50	532 11 04-52	Nut Push Phos & Oil

NOTE: All component dimensions given in U.S. inches
 1 inch = 25.4 mm

**TRACTOR -- MODEL NO. LT2223CMA2 (96061024200), PRODUCT NO. 960 61 02-42
BAGGER 46**

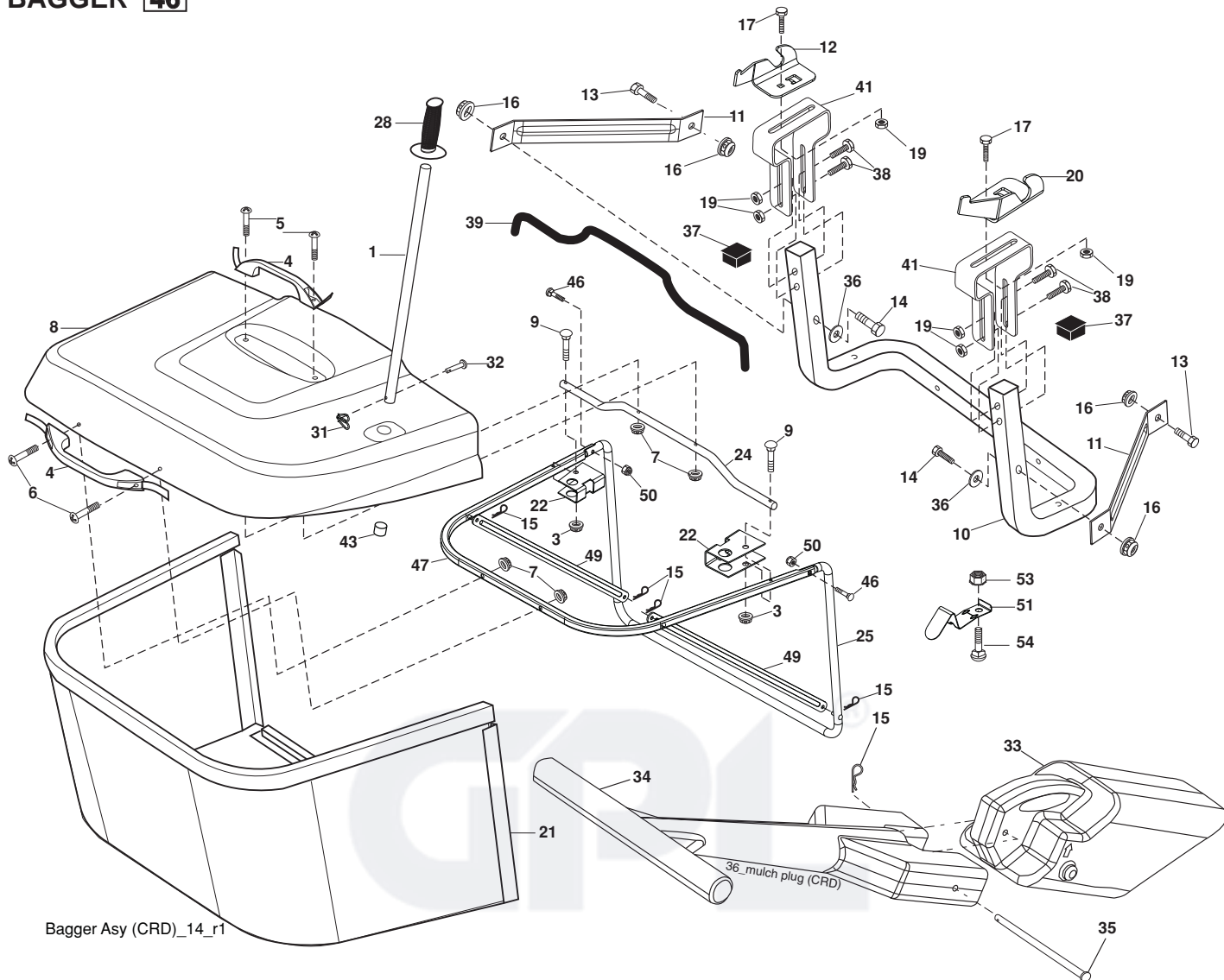

KEY NO.	PART NO.	DESCRIPTION	KEY NO.	PART NO.	DESCRIPTION
1	532 16 52-49	Tube Handle Bagger CRD	28	532 16 57-87	Grip Handle Black
3	532 12 39-76	Nut Lock 1/4 Lge Flg Gr. 5 Zinc	31	532 16 94-84	Retainer Clip Dia. .290
4	532 16 99-16	Handle Bagger w/Lvrs Blk CRD	32	532 12 68-75	Rivet Rd Hd Drilled 3/8 Dia
5	874 98 10-24	Screw Pan Head #10-24 x 1.50 Blk	33	532 16 93-80	Plug Mulcher
6	874 98 10-32	Screw Pan Hd	34	532 16 55-70	Handle Mulcher
7	873 40 10-00	Nut Wiz Lock Hex Serr/Hd 10-24	35	532 16 55-72	Pin Mulcher
8	532 18 13-54	Cover Bagger	36	819 13 20-12	Washer 13/32 x 1-1/4 x 12 Ga.
9	872 14 04-18	Bolt Carriage 1/4-20 x 2.25d x Gr. 5	37	532 17 54-01	Plug Support Bagger CRD
10	532 18 12-82	Tube Support Bagger CRD	38	872 01 05-20	Bolt 5/16-18 x 2-1/2
11	532 16 57-19	Bracket Support Upper Bag CRD	39	532 41 62-57	Seal Trim
12	532 18 88-48	Bracket LH	41	532 16 96-83	Bracket Pnt Adj Pvt Bagger CRD
13	874 76 06-12	Bolt Fin Hex 3/8-16 unc x 3/4	43	532 17 40-83	Plug Tubing End
14	874 52 06-36	Bolt Fin Hex 3/8-16 x 2 x 1/4 Gr. 5	46	872 11 05-10	Bolt Carr. 5/16-18 x 1-1/4 Gr. 5
15	532 12 46-70	Retainer Spring	47	532 19 37-04	Tube Upper Bagger
16	873 90 06-00	Nut Lock Flg 3/8-16 unc	49	532 19 33-05	Bar Spreader Bagger
17	872 14 05-06	Bolt Rdhd Sht Sqnk 5/16-18 uncx3/4	50	873 80 05-00	Nut Lock Hex w/insert 5/16-18 unc
19	873 90 05-00	Nut Lock Hex Flange 5/16-18	51	532 19 99-03	Latch Spring Bagger
20	532 18 88-47	Bracket Horiz Adj Bagger RH	53	873 51 04-00	Nut Keps Hex 1/4-20 unc
21	532 40 61-80	Bag Asm CRD	54	872 14 04-06	Bolt Rdhd Sqnk 1/4-20 x 3/4 Gr. 5
22	532 16 57-81	Bracket Side Bagger CRD			
24	532 16 57-83	Tube Pivot Bagger CRD			
25	532 19 37-05	Tube Front Bagger CRD			

NOTE: All component dimensions given in U.S. inches
1 inch = 25.4 mm

