

**REPAIR PARTS MANUAL**  
**MODEL NO. M12597RB (96061028701)**  
**Lawn Tractor**

---



**McCULLOCH**

[www.mcculloch.biz](http://www.mcculloch.biz)

# HOW TO USE THIS MANUAL

This manual is designed to provide the customer with a means to identify the parts on his/her tractor when ordering repair parts. The illustrations may or may not represent the actual assemblies; therefore, it is not recommended to use this manual as a guide to assemble or disassemble the tractor. Some hardware and parts are drawn larger in order to more readily identify them.

Each tractor has its own model number.

The model number for your tractor can be found on the fender under the seat.

When ordering parts, always give the following information:

- Product - "Tractor"
- Model Number - "M12597RB(96061028701)"
- Part Number
- Part Description

## TABLE OF CONTENTS

SCHEMATIC .....	3
ELECTRICAL.....	4-5
CHASSIS .....	6-7
DRIVE.....	8-9
ENGINE.....	10-11
STEERING .....	12-13
MOWER DECK .....	14-15
MOWER LIFT.....	16
SEAT .....	17
DECALS.....	18
BAGGER.....	19

# TRACTOR - - MODEL NO. M12597RB (96061028701) PRODUCT NO. 960 61 02-87 SCHEMATIC

SCH09

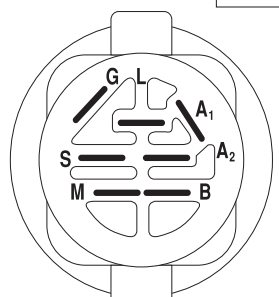
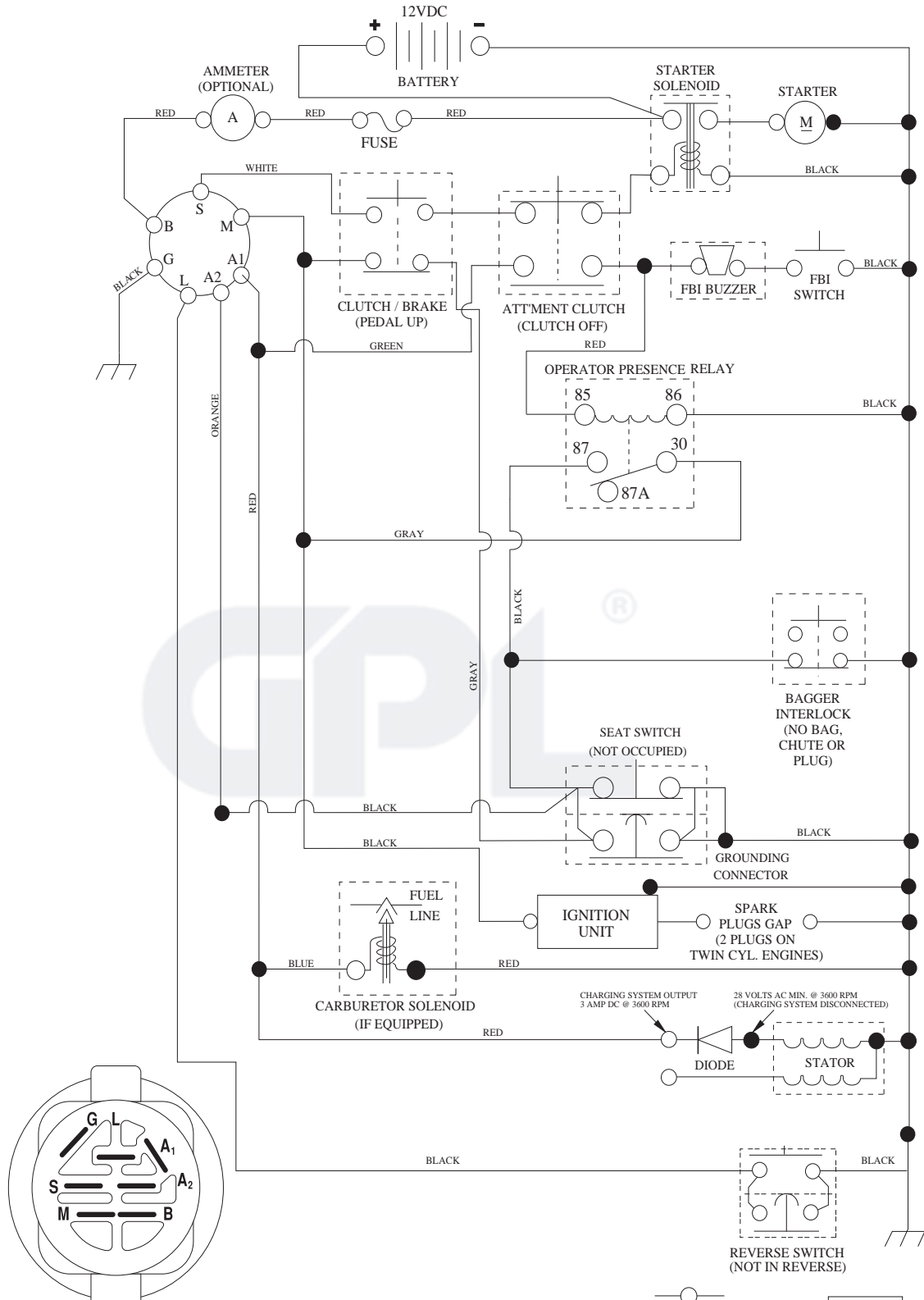

IGNITION SWITCH

POSITION	CIRCUIT	"MAKE"
OFF	M+G+A1	
RUN/OVERRIDE	B+A1	
RUN	B+A1	L+A2
START	B + S + A1	

WIRING INSULATED CLIPS  
NOTE: IF WIRING INSULATED CLIPS WERE REMOVED FOR SERVICING OF UNIT, THEY SHOULD BE RE-INSTALLED TO PROPERLY SECURE YOUR WIRING.

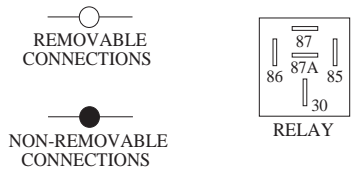

TRACTOR - - MODEL NO. M12597RB (96061028701) PRODUCT NO. 960 61 02-87  
ELECTRICAL

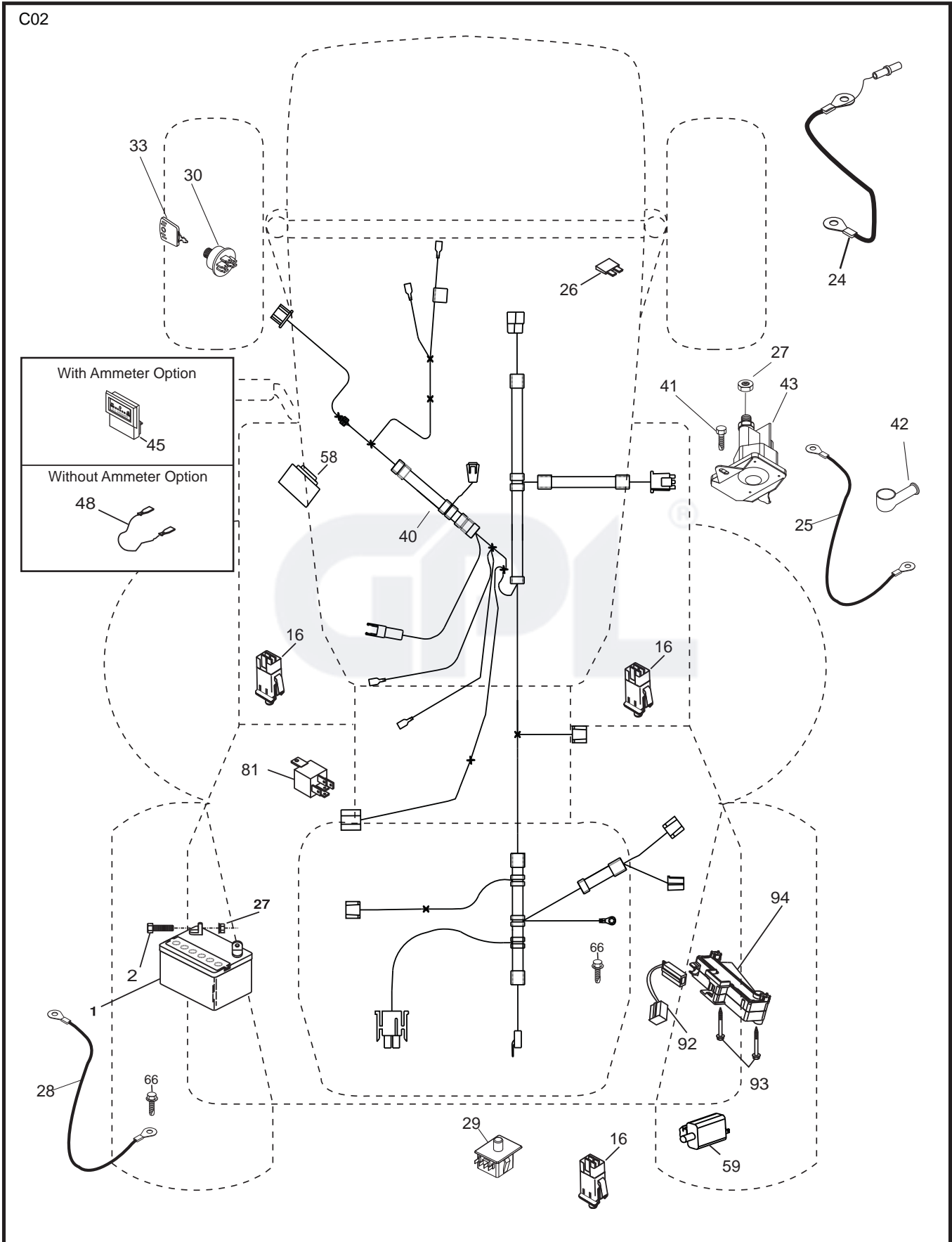

**TRACTOR - - MODEL NO. M12597RB (96061028701) PRODUCT NO. 960 61 02-87  
ELECTRICAL**

<b>KEY NO.</b>	<b>PART NO.</b>	<b>DESCRIPTION</b>
1	532 16 34-65	Battery
2	874 76 04-12	Bolt Hex Hd. 1/4-20 unc x 3/4
16	532 17 61-38	Switch Interlock
24	532 16 59-87	Cable Battery CRD 56" Red
25	532 42 12-99	Cable Starter 6 Ga. 11" Red
26	532 17 51-58	Fuse
27	873 51 04-00	Nut Keps Hex 1/4-20 unc
28	532 12 77-25	Cable Ground 6 Ga. 18" Black
29	532 19 27-49	Switch Seat
30	532 19 33-50	Switch Ignition
33	532 41 19-35	Key/Chain
40	532 19 74-38	Harness Ign.
41	871 11 04-08	Bolt Flk. Fin. Hex 1/4-20 unc x 1/2
42	532 13 15-63	Cover Terminal Red
43	532 19 25-07	Solenoid
48	532 14 08-44	Adapter Ammeter Rectangular
58	532 16 94-19	Buzzer CRD
59	532 18 03-79	Switch FBI CRD
66	817 49 06-08	Screw Thdrol. 3/8-16 x 1/2 Ty-Tt
81	532 10 97-48	Relay Asm.
92	532 19 66-15	Harness Pigtail
93	532 19 25-40	Screw Plastite 10-14 x 2.0
94	532 19 18-34	Module Reverse

**NOTE:** All component dimensions given in U.S. inches.  
1 inch = 25.4 mm.

TRACTOR - - MODEL NO. M12597RB (96061028701) PRODUCT NO. 960 61 02-87  
CHASSIS AND ENCLOSURES

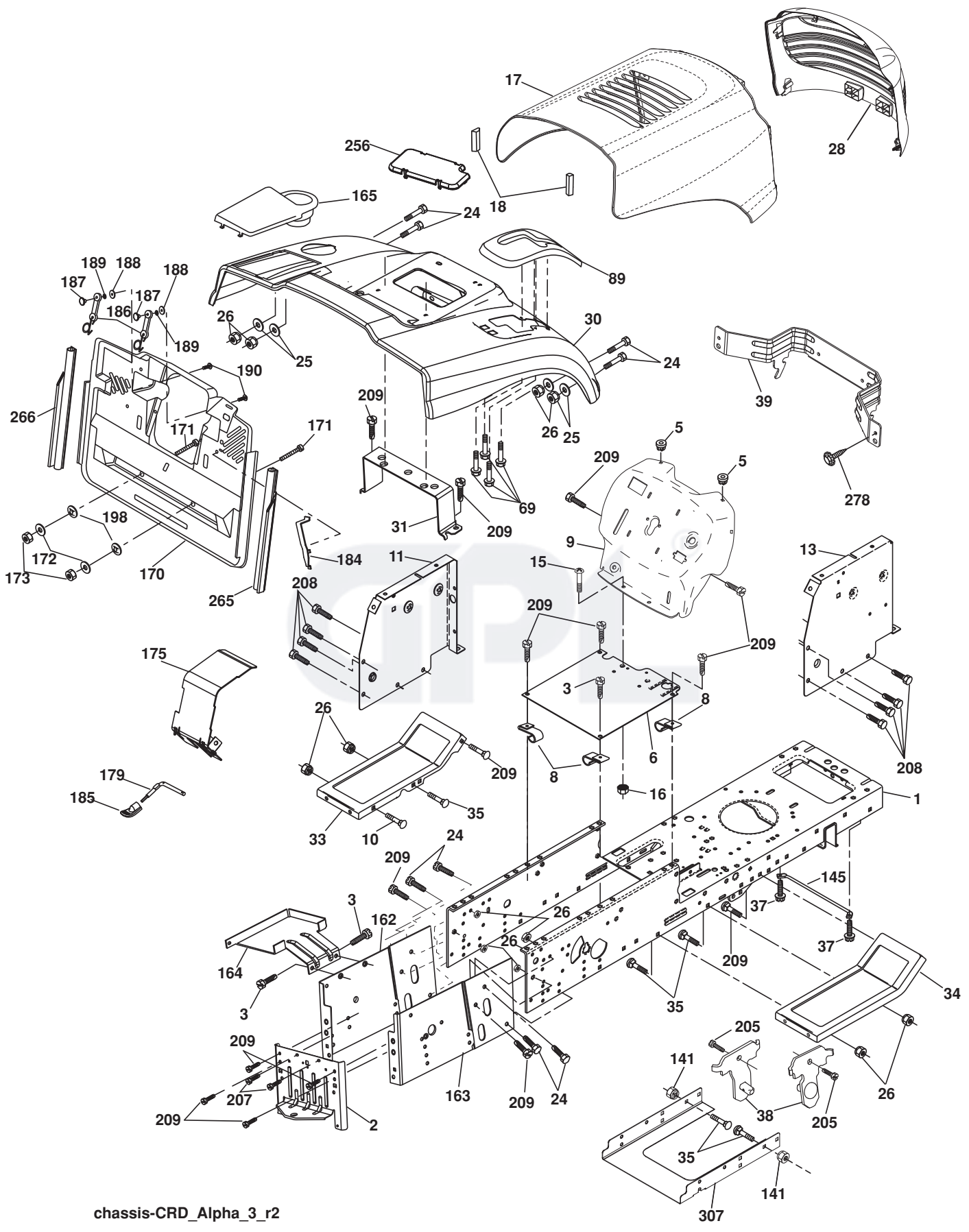

chassis-CRD\_Alpha\_3\_r2

**TRACTOR - - MODEL NO. M12597RB (96061028701) PRODUCT NO. 960 61 02-87  
CHASSIS AND ENCLOSURES**

KEY NO.	PART NO.	DESCRIPTION	KEY NO.	PART NO.	DESCRIPTION
1	532 17 46-20	Chassis	163	532 18 03-83	Bracket Exten Chassis RH CRD
2	532 18 03-84	Drawbar	164	532 16 56-05	Support Battery CRD
3	817 06 06-12	Screw 3/8-16 x 3/4	165	532 18 13-56	Cover Battery
5	532 15 52-72	Bumper Hood/Dash	170	532 19 94-88	Backplate CRD
6	532 18 44-19	Saddle	171	872 14 06-20	Bolt Rdhd. Sqnk. 3/8-16 x 2-1/2 Gr. 5
8	532 12 64-71	Clip Insulator 13/32 Mtg. Hole	172	819 13 20-16	Washer 13/32 x 1-1/4 x 16 Ga.
9	532 19 46-88	Dash	173	873 51 06-00	Nut, Keps Hex 3/8-16 unc
10	872 14 06-08	Bolt, Carriage 3/8-16 x 3/4	175	532 18 82-03	Door Trap
11	532 17 49-96	Panel, Dash, LH	179	532 18 82-02	Rod Pivot FBI CRD
13	532 18 17-19	Panel, Asm. Dash RH	184	532 17 46-62	Bracket Actuator Bagger CRD
15	874 18 05-12	Screw, Machine, Truss Head 5/16-18 unc x 3/4	185	532 18 11-01	Knob Rod Brake Parking
16	873 51 05-00	Nut	186	532 16 07-93	Latch Asm. Mulch/Bagger
17	532 40 61-79	Hood	187	532 12 50-04	Nut Weld
18	532 18 49-21	Bumper Hood	188	819 06 12-16	Washer #10
24	874 78 06-16	Bolt	189	810 07 10-00	Washer Lock #10
25	819 13 13-12	Washer 13/32 x 13/16 x 12 Ga.	190	871 08 10-10	Screw Pan Hd. Phillip 10-24 x 5/8
26	873 80 06-00	Nut	198	532 16 89-37	Nut, Push
28	532 19 47-98	Grille	205	817 49 06-08	Screw Thdrol. 3/8-16 x 1/2
30	532 19 73-64	Fender	207	817 67 05-08	Screw Thdrol. 5/16-18 x 1/2
31	532 16 51-56	Bracket, Fender Support	208	817 67 06-08	Screw Thdrol. 3/8-16 x 1/2
33	532 17 97-16	Footrest, LH	209	817 00 06-12	Screw Hex Wsh. Thdrol. 3/8-16
34	532 17 97-17	Footrest, RH	256	532 18 13-61	Cover Fender Rack
35	872 11 06-06	Bolt	265	532 18 57-04	Seal RH Side Bagger
37	817 49 05-08	Screw Thdrol. 5/16-18 x 1/2 TYT	266	532 18 57-03	Seal LH Side Bagger
38	532 18 17-48	Bracket Asm. Pivot Mower Rear	278	532 41 63-58	Screw #10 x 0.750
39	532 18 75-68	Bracket Pivot	307	532 42 09-19	Shield Chassis Front
69	532 14 24-32	Screw Hx. Wsh. Hi-Lo	--	532 00 54-79	Plug Button
89	532 19 73-39	Console CRD 6 Sp. 418	--	532 19 39-35	Plug Switch Light
141	873 90 06-00	Nut			
145	532 40 91-67	Rod Pivot Chassis/Hood			
162	532 18 03-82	Bracket Exten Chassis LH CRD			

**NOTE:** All component dimensions given in U.S. inches.  
1 inch = 25.4 mm.

# TRACTOR - - MODEL NO. M12597RB (96061028701) PRODUCT NO. 960 61 02-87 DRIVE

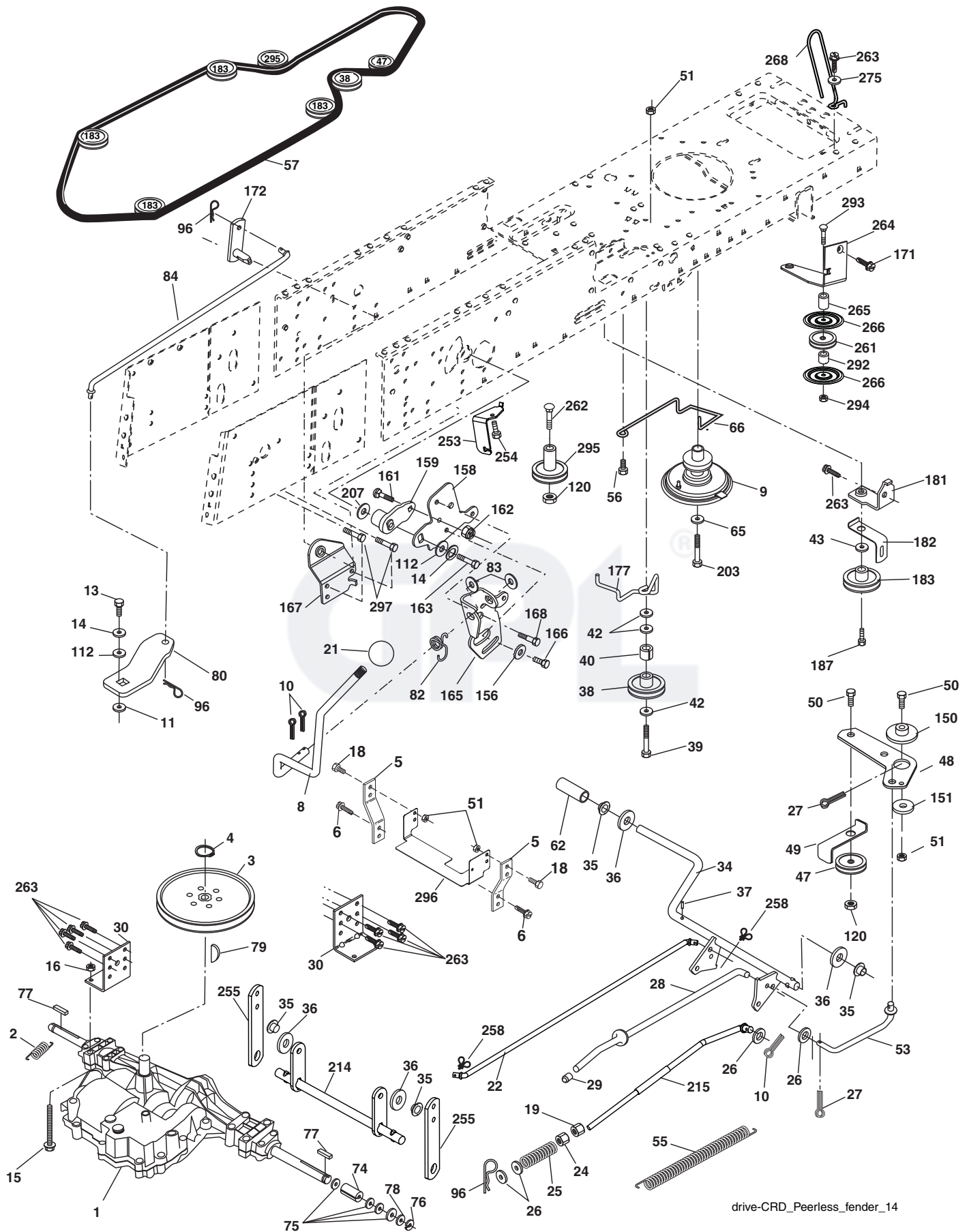



# TRACTOR - - MODEL NO. M12597RB (96061028701) PRODUCT NO. 960 61 02-87 DRIVE

KEY NO.	PART NO.	DESCRIPTION	KEY NO.	PART NO.	DESCRIPTION
1	-----	Transaxle Peerless 206-546	80	532 14 50-90	Arm Shift PMST 20" Tires
2	532 14 66-82	Spring Brake Return	82	532 16 57-11	Spring, Torsion
3	532 16 59-99	Pulley Transaxle	83	819 17 12-16	Washer 17/32 x 3/4 x 16 Ga.
4	812 00 00-28	Ring Retainer #5100-62	84	532 16 56-21	Link Shift
5	532 12 15-20	Strap Torque 30 Degrees	96	532 12 47-88	Spring, Retainer 1"
6	817 06 05-12	Screw 5/16-18 x 3/4	112	819 09 12-10	Washer 9/32 x 3/4 x 10 Ga.
8	532 19 27-06	Rod Shift	120	873 90 06-00	Nut Lock Flg. 3/8-16 unc
9	532 40 85-79	Clutch Noram	150	532 16 58-50	Bushing, Bellcrank Grnd. Dr.
10	876 02 04-16	Pin, Cotter 1/8 x 1	151	819 13 32-10	Washer 13/32 x 2 x 10 Ga.
11	532 10 57-01	Washer Plate Shf. .3888 Sq. Hole	156	532 16 60-02	Washer Srred. 5/16 ID x 1.125
13	874 55 04-12	Bolt 1/4-28 unf Gr. 8 w/Patch	158	532 16 55-89	Bracket Shift Mount
14	810 04 04-00	Washer, Lock Hvy. Helical	159	532 18 39-00	Hub Shift
15	874 49 05-44	Bolt Hex Flg. Hd. 5/16-18 Gr. 5	161	872 14 04-06	Bolt Rdhd. Sqnk. 1/4-20 x 3/4 Gr. 5
16	873 80 05-00	Nut, Lock Hex w/Ins. 5/16-18 unc	162	873 68 04-00	Nut Crownlock 1/4-20 unc
18	874 78 06-16	Bolt Hex 3/8-16 unc x 1 Gr. 5	163	874 78 04-16	Bolt Hex Fin. 1/4-20 unc x 1 Gr. 5
19	873 80 06-00	Nut, Lock Hex w/Wsh. 3/8-16 unc	165	532 16 56-23	Bracket Pivot Lever
21	532 10 69-33	Knob Duckhead	166	817 49 05-10	Screw 5/16-18 x 5/8
22	532 17 56-07	Rod, Brake CRD	167	532 16 55-88	Bracket Support Shift CRD
24	873 35 06-00	Nut	168	532 16 54-92	Bolt Shoulder 5/16-18 x .561
25	532 10 68-88	Spring, Rod, Brake	171	817 49 06-08	Bracket Idler Chass Noram
26	819 13 13-16	Washer 13/32 x 13/16 x 16 Ga.	172	532 16 56-35	Shaft Asm. Shift Front
27	876 02 04-12	Pin, Cotter 1/8 x 3/4	177	532 16 59-32	Keeper Flat Idler 3.06" CRD
28	532 17 57-65	Rod, Parking Brake	181	532 18 02-11	Bracket Idler Ground Drive CRD
29	532 07 16-73	Cap Brake Parking	182	532 18 26-82	Keeper Belt 2.5" Od. V-Idler CRD
30	532 17 49-73	Bracket, Mfg. Transaxle	183	532 19 95-34	Pulley V-Idler
34	532 17 55-78	Shaft, Asm. Pedal Foot	187	817 58 05-20	Screw 5/16-18 x 1.25
35	532 12 01-83	Bearing, Nylon	203	871 17 07-80	Bolt Hex 7/16-20 x 5
36	819 21 16-16	Washer 21/32 x 1 x 16 Ga.	207	532 16 98-45	Washer Nylon Rear
37	532 12 49-63	Pin, Roll 3/16 x 1"	214	532 17 56-09	Shaft Asm. Blade
38	532 16 59-36	Pulley, Flat	215	532 41 01-42	Rod Brake Secondary
39	874 76 06-44	Bolt Fin Hex 3/8-16 unc x 2-3/4	253	532 17 50-28	Bracket Cable Chassis
40	532 12 49-65	Spacer, Split 395 x 59 Bzp.	254	817 00 06-16	Screw 3/8-16 x 1
42	819 13 13-12	Washer 13/32 x 13/16 x 12 Ga.	255	532 17 56-08	Brace Shaft Brake Mtg.
43	819 11 10-12	Washer 11/32 x 5/8 x 12 Ga.	258	532 17 80-62	Clip Retainer
47	532 12 77-83	Pulley, Idler, V Groove Plastic	261	532 13 14-94	Spacer Noram CRD
48	532 15 44-07	Bellcrank Clutch Grnd. Drv.	262	872 11 06-22	Bolt Rdhd. 3/8-16 unc x 2-3/4 Gr. 5
49	532 12 32-05	Retainer, Belt Style Spring	263	817 00 06-12	Screw 3/8-16 x 3/4
50	872 11 06-12	Bolt 3/8-16 unc x 1-1/2	264	532 43 11-74	Spacer
51	873 68 06-00	Nut, Crownlock 3/8-16 unc	265	532 42 69-13	Spacer Idler CRD
53	532 19 96-52	Link, Clutch 7.66	266	532 18 20-61	Shield Idler Mower CRD
55	532 10 57-09	Spring, Return, Clutch	268	532 18 24-02	Guard Muffler RH
56	817 06 06-20	Screw 3/8-16 x 1-1/4	275	819 13 16-14	Washer 13/32 x 1 x 1.4 Ga.
57	532 16 56-31	V-Belt Drive	292	532 40 02-71	Bolt RDHD SQNK 3/8-16 x 3-1/2
62	532 12 48-72	Cover, Pedal	293	872 14 06-28	Nut Jam 3/8-16
65	810 04 07-00	Washer	294	532 19 70-33	Screw Thdrol 3/8-16 x1/2 TY-YY
66	532 15 47-78	Keeper, Belt Engine F-Proof	295	532 17 91-14	Pulley Idler
74	532 13 70-57	Spacer Axle	296	532 42 09-20	Shield Chassis Rear
75	532 12 17-49	Washer 25/32 x 1-1/4 x 16 Ga.	297	817 49 06-10	Screw Hxwsh Thd 3/8-16 x 5/8
76	812 00 00-01	Ring, E			
77	532 12 35-83	Key, Square			
78	532 12 17-48	Washer 25/32 x 1-5/8 x 16 Ga.			
79	532 12 50-96	Key Woodruff			

**NOTE:** All component dimensions given in U.S. inches  
1 inch = 25.4 mm

**TRACTOR - - MODEL NO. M12597RB (96061028701) PRODUCT NO. 960 61 02-87  
ENGINE**

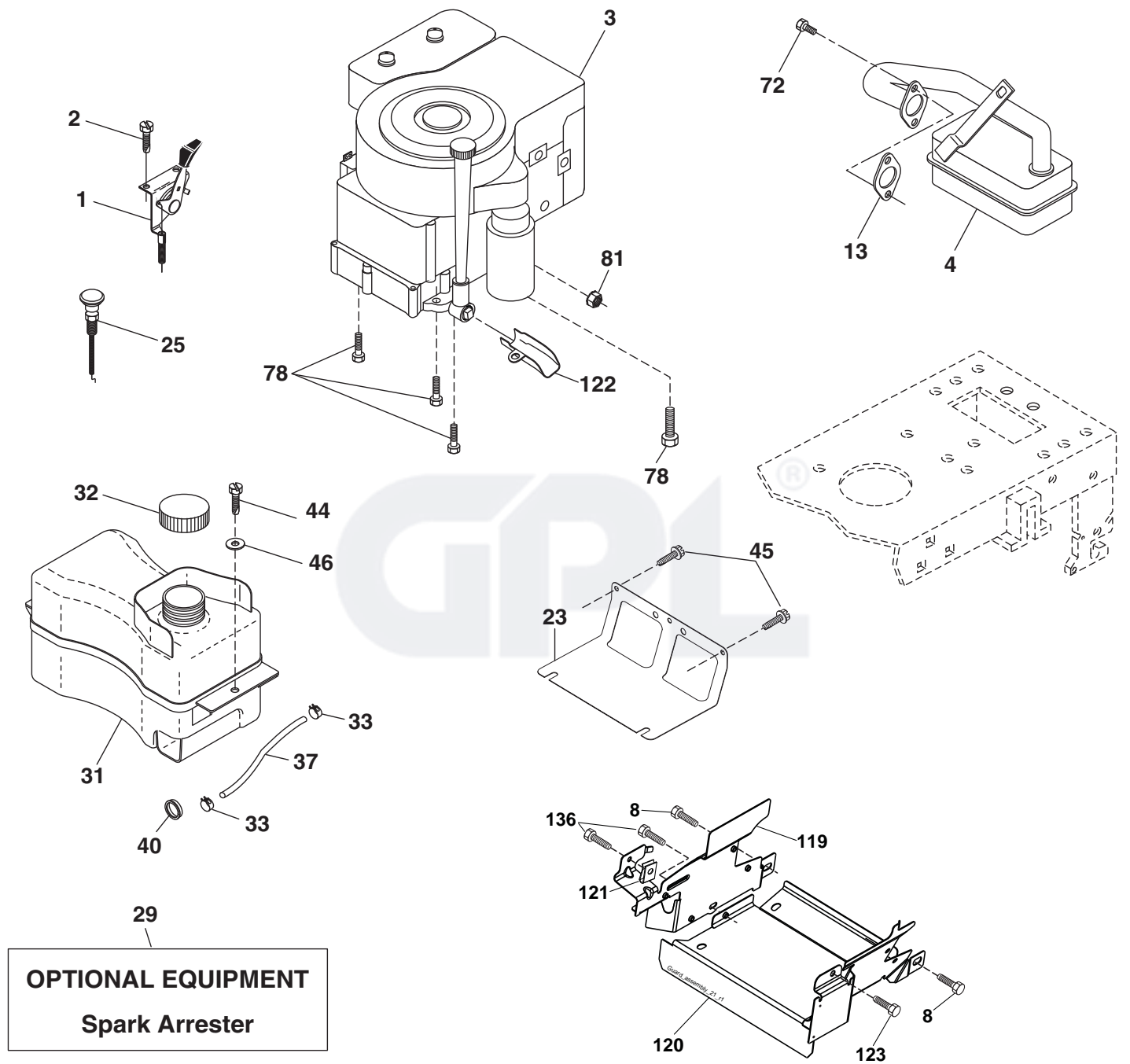

engine-CRD\_bs\_19

# TRACTOR - - MODEL NO. M12597RB (96061028701) PRODUCT NO. 960 61 02-87 ENGINE

KEY NO.	PART NO.	DESCRIPTION
1	532 17 05-51	Control Throt. /Ch. Flag
2	817 72 04-08	Screw Hex Thd. Cut 1/4-20 x 1/2
3	-----	Engine Briggs 219807-1402-B1
4	532 17 97-58	Muffler
8	532 17 18-77	Bolt 5/16-18 x 3/4
13	532 16 52-91	Gasket
23	532 16 98-37	Shield Browning/Debris Guard
25	532 19 06-95	Control Choke
29	532 13 71-80	Arrester Spark
31	532 40 75-16	Tank Fuel
32	532 43 02-20	Cap Asm. Fuel
33	532 12 34-87	Clamp Hose Blk.
37	532 13 70-40	Line Fuel 20"
40	532 12 40-28	Bushing
44	817 67 04-12	Screw Hex Wsh. Thdrol. 1/4-20 x 3/4
45	817 00 06-12	Screw Hex Wsh. Thdrol. 3/8-16 x 3/4
46	819 09 14-16	Washer 9/32 x 7/8 x 16 Ga.
72	532 19 23-34	Screw Socket HD 5/16-18 x .75
78	817 06 06-20	Screw 3/8-16 x 1-1/4
81	873 51 04-00	Nut Keps 1/4-20 unc
119	532 19 97-68	Guard Engine LH
120	532 19 97-67	Guard Engine RH
121	532 19 66-88	Clips Threaded
122	532 42 19-22	Extension Drain Oil
123	817 67 05-08	Screw Thdrol. 5/16-18 x 1/2
136	532 13 77-29	Screw Thdrol. 1/4-20 x 5/8

**NOTE:** All component dimensions given in U.S. inches  
1 inch = 25.4 mm

## Engine Power Rating Information

The gross power rating for individual gas engine models is labeled in accordance with SAE (Society of Automotive Engineers) code J1940 (Small Engine Power & Torque Rating Procedure), and rating performance has been obtained and corrected in accordance with SAE J1995 (Revision 2002-05). Torque values are derived at 3060 RPM; horsepower values are derived at 3600 RPM. Actual gross engine power will be lower and is affected by, among other things, ambient operating conditions and engine-to-engine variability. Given both the wide array of products on which engines are placed and the variety of environmental issues applicable to operating the equipment, the gas engine will not develop the rated gross power when used in a given piece of power equipment (actual "on-site" or net power). This difference is due to a variety of factors including, but not limited to, accessories (air cleaner, exhaust, charging, cooling, carburetor, fuel pump, etc.), application limitations, ambient operating conditions (temperature, humidity, altitude), and engine-to-engine variability. Due to manufacturing and capacity limitations, Briggs & Stratton may substitute an engine of higher rated power for this Series engine.

**TRACTOR - - MODEL NO. M12597RB (96061028701) PRODUCT NO. 960 61 02-87  
STEERING ASSEMBLY**

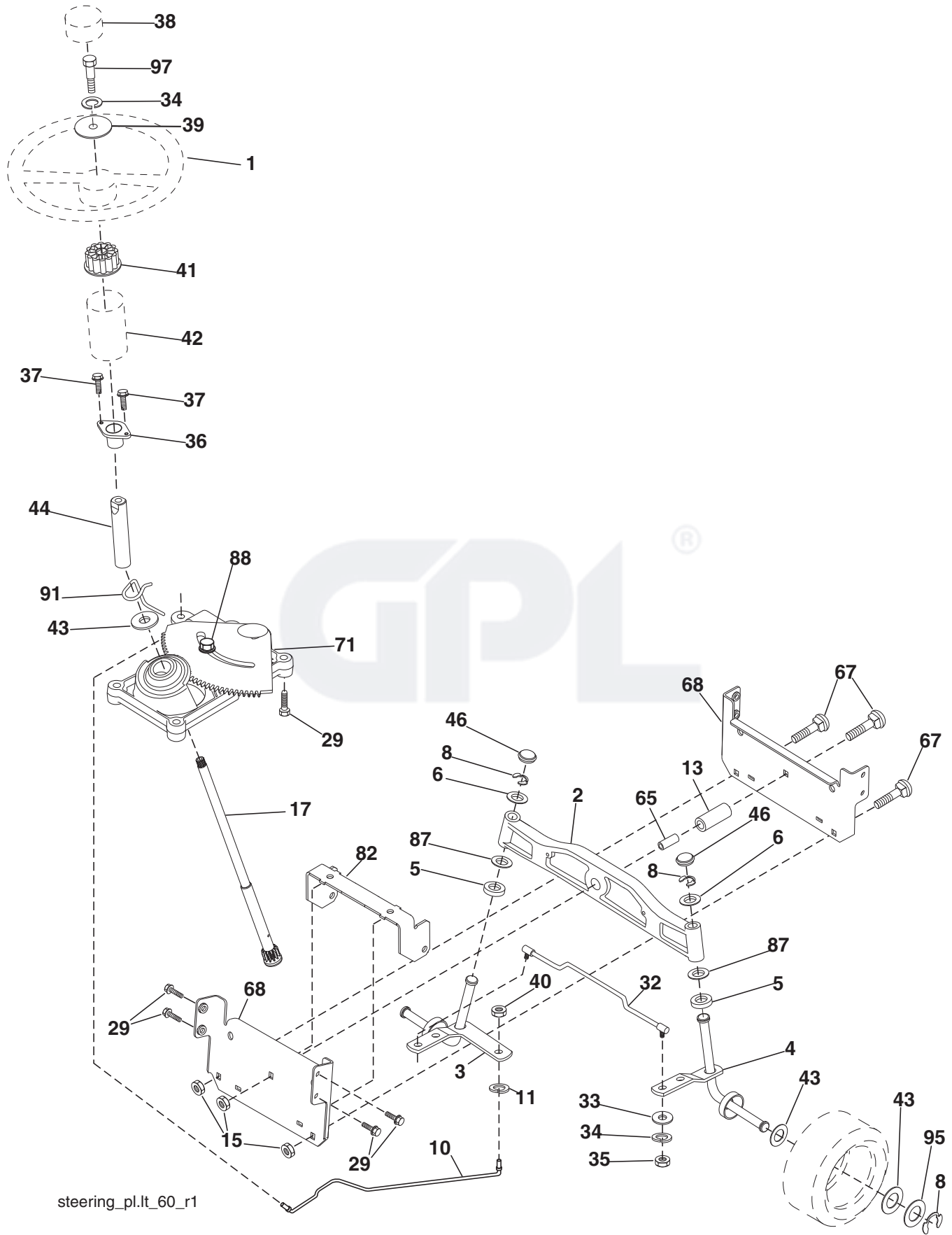

**TRACTOR - - MODEL NO. M12597RB (96061028701) PRODUCT NO. 960 61 02-87  
STEERING ASSEMBLY**

<b>KEY NO.</b>	<b>PART NO.</b>	<b>DESCRIPTION</b>
1	532 42 45-43	Steering Wheel
2	532 18 47-06	Axle Asm. Cast Iron Lt.
3	532 16 98-40	Spindle Assembly, LH
4	532 16 98-39	Spindle Assembly, RH
5	532 12 49-31	Bearing, Race, Thrust, Hardened
6	532 12 17-48	Washer 25/32 x 1-5/8 x 16 Ga.
8	812 00 00-29	Ring, Clip
10	532 17 51-21	Link, Drag
11	810 04 06-00	Washer, Lock
13	532 13 65-18	Spacer Brg. Axle Front
15	873 90 06-00	Nut Lock Flg. 3/8-16
17	532 19 07-53	Shaft, Steering
29	817 00 06-12	Screw 3/8-16 x 3/4
32	532 17 01-62	Rod, Tie
33	819 11 12-16	Washer 11/32 x 3/4 x 16 Ga.
34	810 04 05-00	Washer Lock Hvy. Hlcl. Spr. 5/16
35	873 54 05-00	Crownlock Nut 5/16-24 unf 3847
36	532 15 50-99	Bushing, Steering
37	532 15 29-27	Screw TT #10-32 x 5 x 3/8 Flange
38	532 42 46-91	Cap Wheel Steering
39	819 11 38-12	Washer 11/32 ID x 2- 3/8 OD x 12 Ga.
40	876 54 06-00	Nut Lock 3/8-24
41	532 18 67-37	Adaptor, Steering Wheel
42	532 16 96-33	Boot, Steering Dash P/L Mtl.
43	532 12 17-49	Washer 25/32 x 1-1/4 x 16 Ga.
44	532 19 07-52	Extension Steering Shaft
46	532 12 12-32	Cap, Spindle
65	532 41 47-36	Spacer Brace Axle
67	872 11 06-18	Bolt Rdhd. Sqnk. 3/8-16 x 2-1/4
68	532 16 98-27	Brace Axle
71	532 17 51-46	Steering Asm.
82	532 19 99-78	Bracket Susp. Chassis Front
87	532 17 39-66	Washer Flat .781 x 1 1/2 x .14
88	532 17 51-18	Bolt Shoulder 7/16-20 unc
91	532 17 55-53	Clip Steering
95	532 18 89-67	Washer
97	532 42 89-82	Bolt 5/16-18 unc x 4" L. Gr. 5

**NOTE:** All component dimensions given in U.S. inches.  
1 inch = 25.4 mm.

TRACTOR - - MODEL NO. M12597RB (96061028701) PRODUCT NO. 960 61 02-87  
MOWER

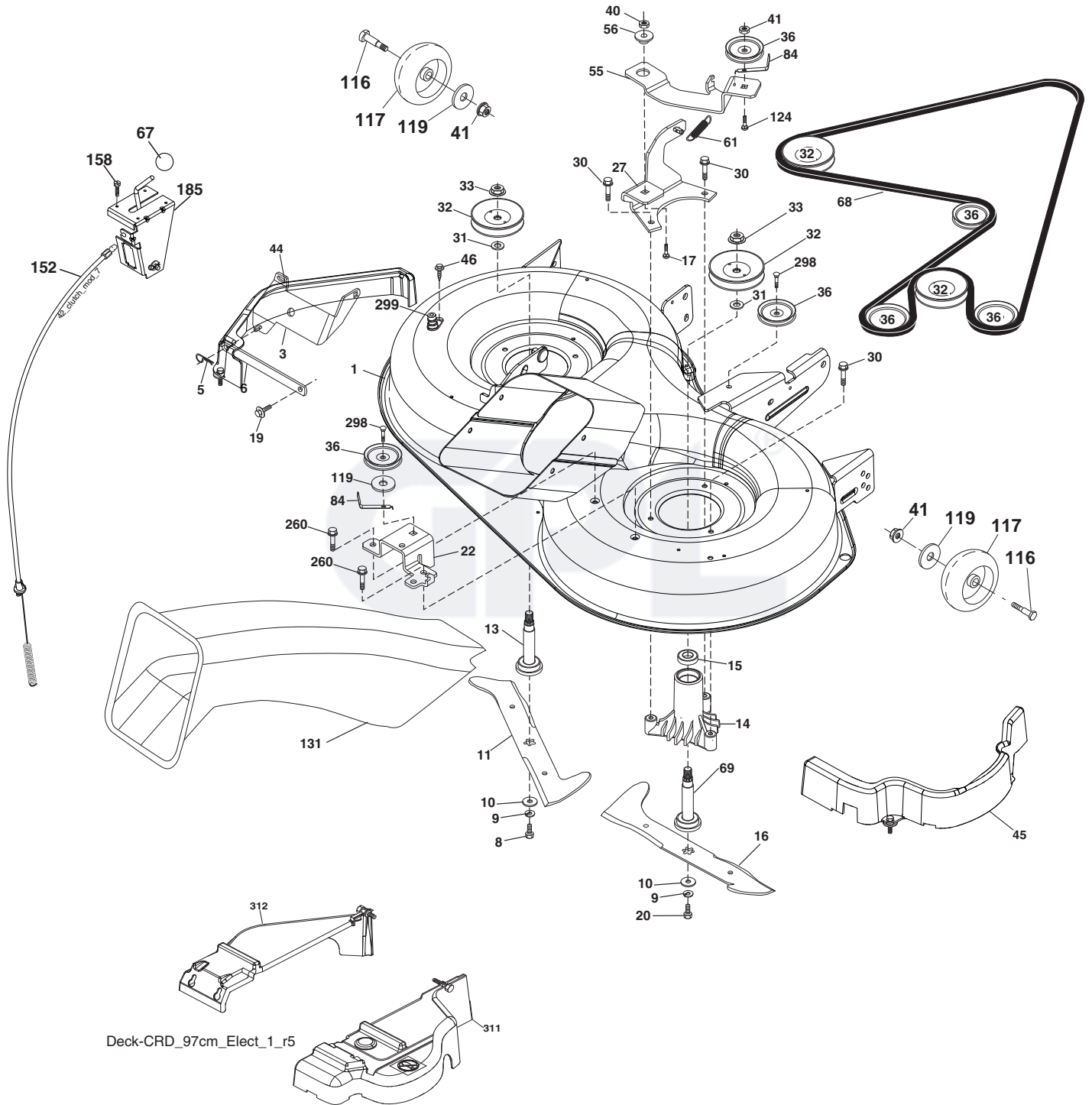

Deck-CRD\_97cm\_Elect\_1\_r5

**TRACTOR - - MODEL NO. M12597RB (96061028701) PRODUCT NO. 960 61 02-87  
MOWER**

KEY NO.	PART NO.	DESCRIPTION	KEY NO.	PART NO.	DESCRIPTION
1	532 42 91-21	Housing Asm. Mower 97 CRD	61	532 19 94-86	Spring Tension Belt
3	532 43 18-64	Bracket Asm. S-Bar Chass 97 CRD	67	532 10 69-32	Knob Rd.
5	532 12 46-70	Retainer Spring	68	532 42 95-32	Belt Drive 97 Mower
6	532 16 55-57	Bar Sway 97 CRD	69	532 16 54-82	Shaft Asm w/Lwr Brg RH Thd CRD
8	532 18 17-12	Bolt 3/8-24 x 1.25 Gr. 8 Patched	84	532 15 60-85	Keeper Belt Idler
9	810 03 06-00	Washer Lock Hvy 3/8 Unplated	116	532 19 34-06	Bolt Shoulder
10	532 14 02-96	Washer Hard	117	532 17 48-73	Wheel Gage
11	532 42 79-84	Blade 3-1 LH 97 CRD	119	819 13 20-12	Washer 13/32 x 1-1/4 x 12 GA.
13	532 13 76-45	Shaft Asm. w/Lower Bearing	124	872 11 06-12	Bolt Carr Sh 3/8-16 x 1-1/2 Gr. 5
14	532 12 87-74	Housing Mandrel Vented (Machd)	131	532 16 56-61	Chute Bagger CRD 97cm
15	532 11 04-85	Bearing Ball Mandrel	152	532 17 60-74	Cable Clutch
16	532 42 79-85	Blade 3-1 RH 97 CRD Rear RH	158	817 72 04-08	Screw Thd Cut 1/4-20 x 1/2
17	872 14 06-10	Bolt Carriage 3/8-16 x 1-1/4	185	532 18 82-34	Head Asm. Cable Clutch
19	532 13 28-27	Bolt Shoulder 5/16-18 Thd Form	260	817 67 06-08	Screw Thdrol 3/8-16 x 1/2
20	532 18 17-13	Bolt 3/8-24 x 1.25 Gr. 8 Ptch Lhthd	298	817 49 06-28	Screw Thdrol 3/8-16 x 1-3/4
22	532 43 11-69	Bracket Idler Sprt 97 CRD Rear RH	311	532 43 07-75	Cover Deck LH
27	532 42 79-81	Bracket Asm. Susp. Rear RH	312	532 43 07-74	Cover Deck RH
30	532 17 39-84	Screw Thd Rolling	--	532 18 18-57	Mandrel Assembly (Includes hous- ing, shaft assembly, and bear- ing only - pulley/nut/washer and blade bolt/washers not included)
31	532 18 76-90	Washer Spacer Mower Vented			
32	532 15 35-32	Mandrel Pulleys			
33	532 40 02-34	Nut Flg Top Lock	--	532 18 18-58	Mandrel Asm CRDLH Threads SVC
36	532 14 67-63	Pulley Idler V-Groove Dim 4.25	--	532 43 30-38	Replacement Mower, Complete (Std. Deck - Order separately guage wheel componentskeynos. 116, 117 & 119)
40	873 68 06-00	Nut Crownlock 3/8-16 unc			
41	873 90 06-00	Nut Lock Flg. 3/8-16 unc			
44	532 43 02-10	Cover Mandrel LH 97 CRD			
45	532 43 02-09	Cover Mandrel RH 97 CRD			
55	532 19 94-98	Arm Idler 97 CRD			
56	532 16 57-23	Spacer Retainer Mower			

**NOTE:** All component dimensions given in U.S. inches  
1 inch = 25.4 mm

**TRACTOR - - MODEL NO. M12597RB (96061028701) PRODUCT NO. 960 61 02-87  
MOWER LIFT**

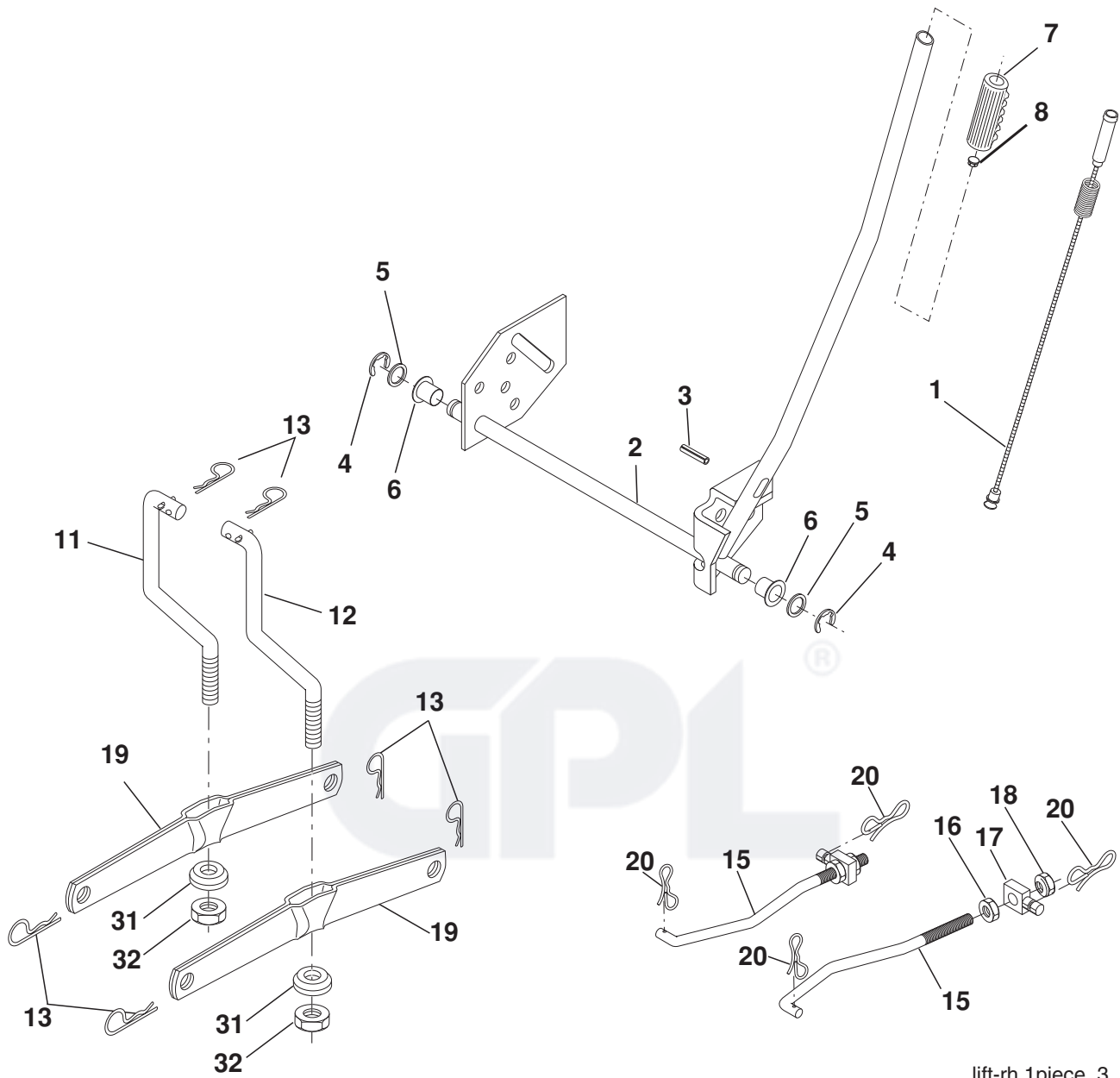

lift-rh.1piece\_3

KEY NO.	PART NO.	DESCRIPTION
1	532 40 49-81	Plunger Asm. Lift Lever
2	532 15 94-71	Shaft Asm. Lift
3	532 10 57-67	Pin Groove
4	812 00 00-02	E Ring #5133-62
5	819 21 16-21	Washer 21/32 x 1 x 21 Ga.
6	532 12 01-83	Bearing Nylon
7	532 10 94-13	Grip Handle
8	532 12 45-26	Button Plunger Black
11	532 13 98-65	Link Lift LH
12	532 13 98-66	Link Lift RH
13	532 12 46-70	Retainer Spring
15	532 17 32-88	Link Front

KEY NO.	PART NO.	DESCRIPTION
16	873 35 08-00	Nut Jam Hex 1/2-13 unc
17	532 17 56-89	Trunnion
18	873 80 08-00	Nut Lock w/Wsh. 1/2-13 unc
19	532 13 98-68	Arm, Suspension Mower
20	532 19 42-09	Pin Cotter 7/16 Bow Tie Lock
31	532 16 98-65	Bearing, Pvt. Lift.
32	873 54 06-00	Nut Crownlock 3/8-24

**NOTE:** All component dimensions given in U.S. inches.  
1 inch = 25.4 mm



# TRACTOR - - MODEL NO. M12597RB (96061028701) PRODUCT NO. 960 61 02-87 SEAT ASSEMBLY

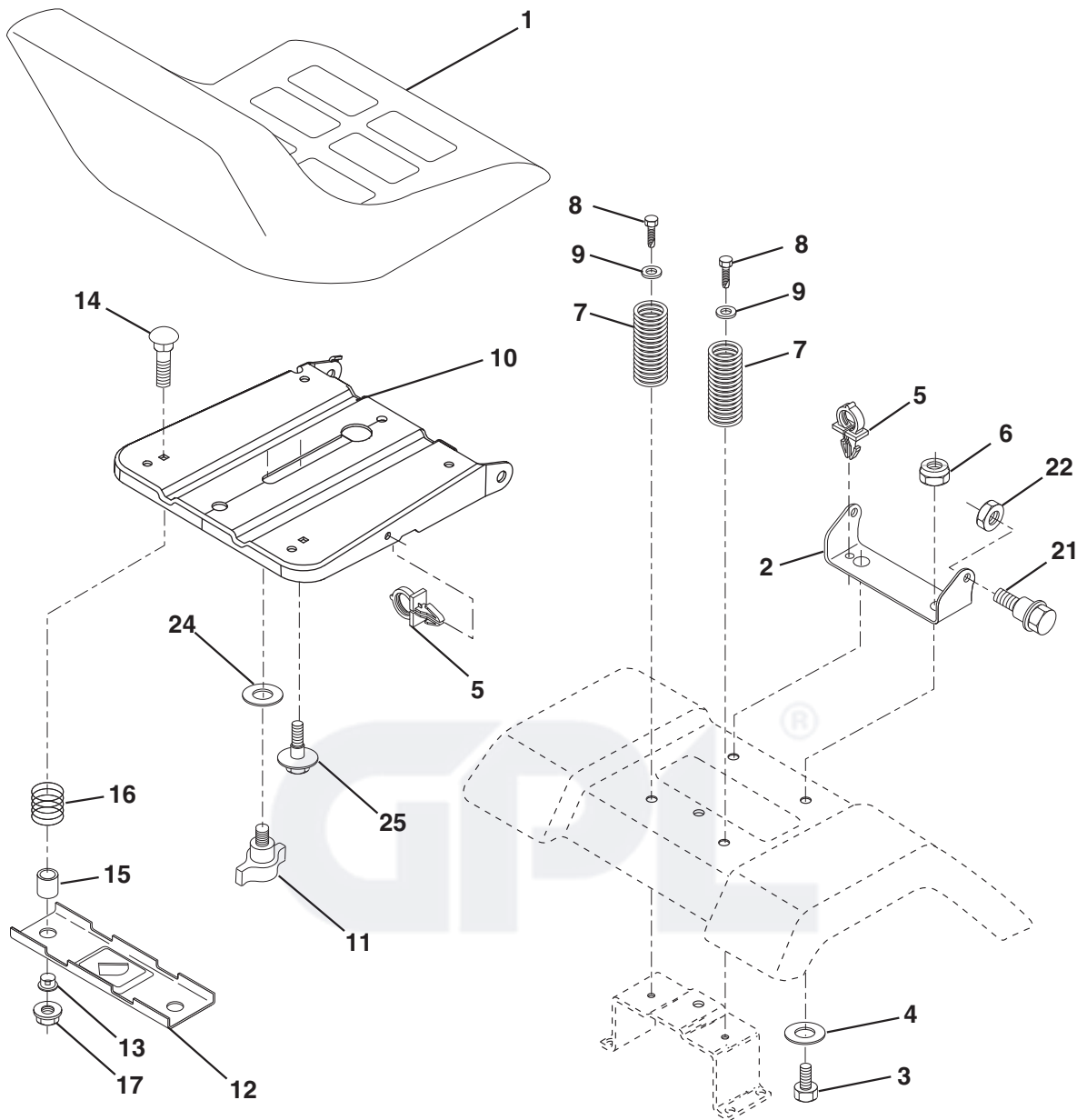

seat\_it.knob\_13

KEY NO.	PART NO.	DESCRIPTION	KEY NO.	PART NO.	DESCRIPTION
1	532 40 10-42	Seat	14	872 05 04-12	Bolt Rdhd. Sht. Nk. 1/4-20 x 1-1/2
2	532 14 05-51	Bracket Pnt. Pivot Seat (Blk.)	15	532 13 43-00	Spacer Split
3	871 11 06-16	Bolt Fin. Hex 3/8-16 x 1	16	532 12 12-50	Spring Cprsn. Plate SW 1.310 Ga.
4	819 13 16-10	Washer Flat 13/32 x 1 x 10 Ga.	17	532 12 39-76	Nut Lock 1/4 Lge. Flg. Gr. 5 Zinc
5	532 14 50-06	Clip Push In Hinged	21	532 17 18-52	Bolt Shoulder 5/16-18 unc-2A
6	873 80 06-00	Nut Lock Hx. w/Ins. 3/8-16	22	873 80 05-00	Nut Hex Lock w/Ins. 5/16-18
7	532 12 41-81	Spring Seat Cprsn. 2 250 Blk. Zi.	24	819 17 19-12	Washer 17/32 x 1-3/16 x 12 Ga.
8	817 00 06-16	Screw 3/8-16 x 1-1/2	25	532 12 70-18	Bolt Shoulder 5/16-18 x 62
9	819 13 16-14	Washer 13/32 x 1 x 14 Ga.			
10	532 19 55-30	Pan Pnt. Seat			
11	532 16 63-69	Knob Seat			
12	532 17 46-48	Bracket Pnt. Mounting Switch			
13	532 12 12-48	Bushing Snap Blk. Nyl. 50 Id.			

**NOTE:** All component dimensions given in U.S. inches.  
1 inch = 25.4 mm

**TRACTOR - - MODEL NO. M12597RB (96061028701) PRODUCT NO. 960 61 02-87  
DECALS**

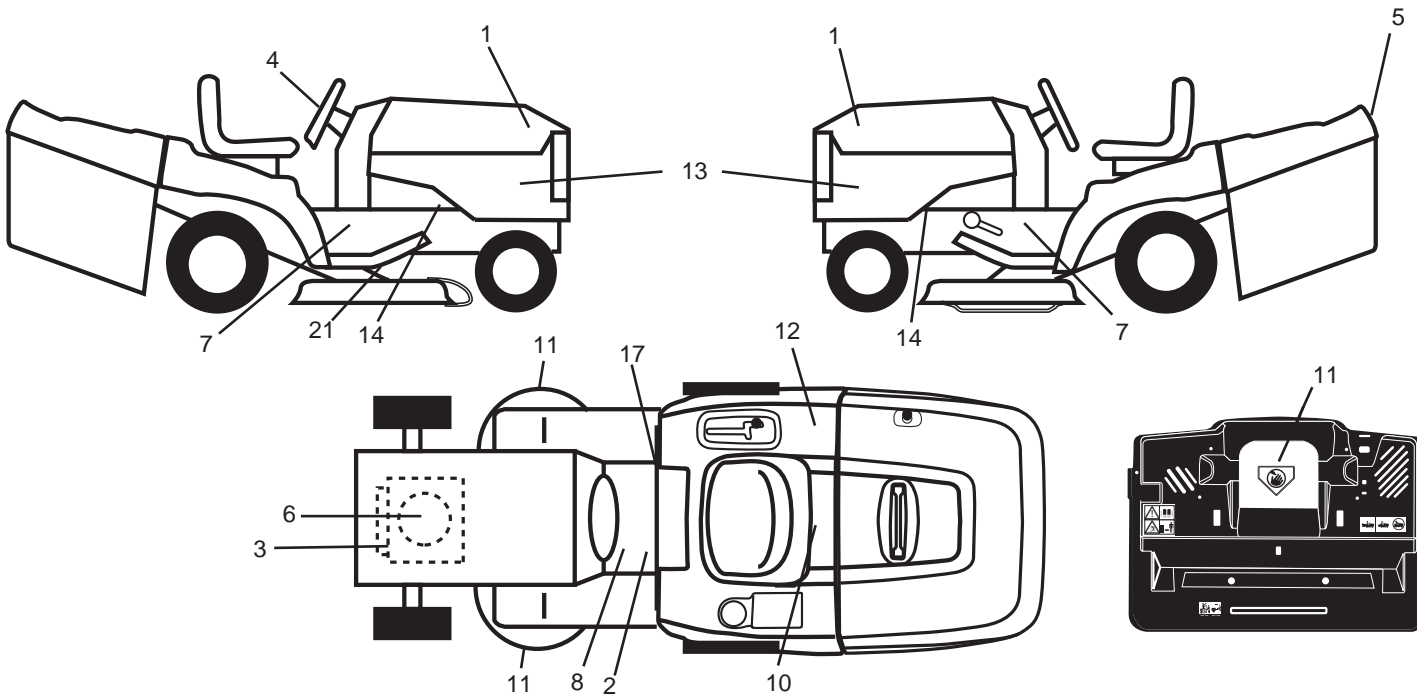

KEY NO.	PART NO.	DESCRIPTION
1	532 43 12-21	Decal Hood RH
2	532 40 03-89	Decal Warning Symbols CE
3	532 41 79-26	Decal HP Engine
4	532 42 42-36	Decal Steering Wheel
5	532 43 12-23	Decal Fender Logo
6	532 19 68-41	Decal Warning Engine Symbols
7	532 40 11-46	Decal Warning Service/Fire
8	532 15 97-37	Decal Brake/Clutch Symbol
10	532 14 50-05	Decal Bat. Dan./Poi. P/L Sym. Wpn.
11	532 18 21-66	Decal Mower Cut Finger Symbol

KEY NO.	PART NO.	DESCRIPTION
12	532 18 04-32	Decal Fender 100 DB/CE
13	532 43 35-81	Decal Side Panel
14	532 15 97-36	Decal Chassis Hot Muffler
17	532 14 08-37	Decal Saddle Brake Parking
21	532 16 62-86	Decal Deck Sch 92 CRD
—	532 18 10-91	Pad Footrest LH
—	532 18 10-90	Pad Footrest RH
—	532 13 83-11	Decal Lift Handle
—	532 43 30-30	Manual Operator's (Euro)
—	532 43 49-40	Manual Parts

**WHEELS & TIRES**

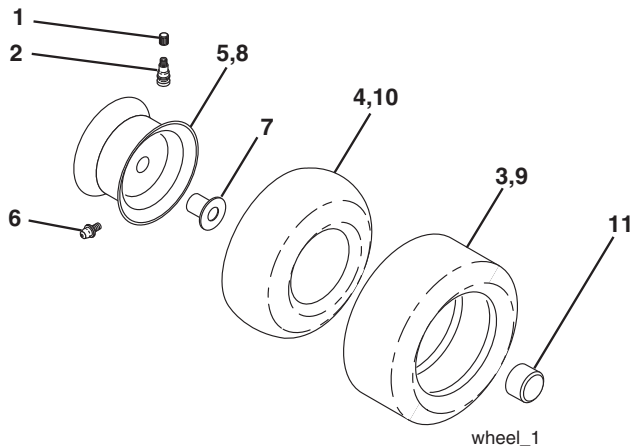

KEY NO.	PART NO.	DESCRIPTION
1	532 05 91-92	Cap Valve Tire
2	532 06 51-39	Stem Valve
3	532 10 62-22	Tire F Ts 15 x 6 0 - 6
4	532 05 99-04	Tube Inner Front #35060
5	532 12 51-21	Rim Asm. Front
6	532 12 49-57	Fitting Grease
7	532 12 49-59	Bearing Flange
8	532 12 51-22	Rim Asm. 8" Rear
9	532 42 05-31	Tire Rear 18 x 9.5-8 "Turf Saver LT"
10	532 12 49-26	Tube Rear 9 5 x 8
11	532 17 50-39	Cap Axle Blk. 1 50 x 1 00
--	532 14 43-34	Sealant, Tire (10 oz. tube)

**NOTE:** All component dimensions given in U.S. inches.  
1 inch = 25.4 mm

# TRACTOR - - MODEL NO. M12597RB (96061028701) PRODUCT NO. 960 61 02-87 BAGGER

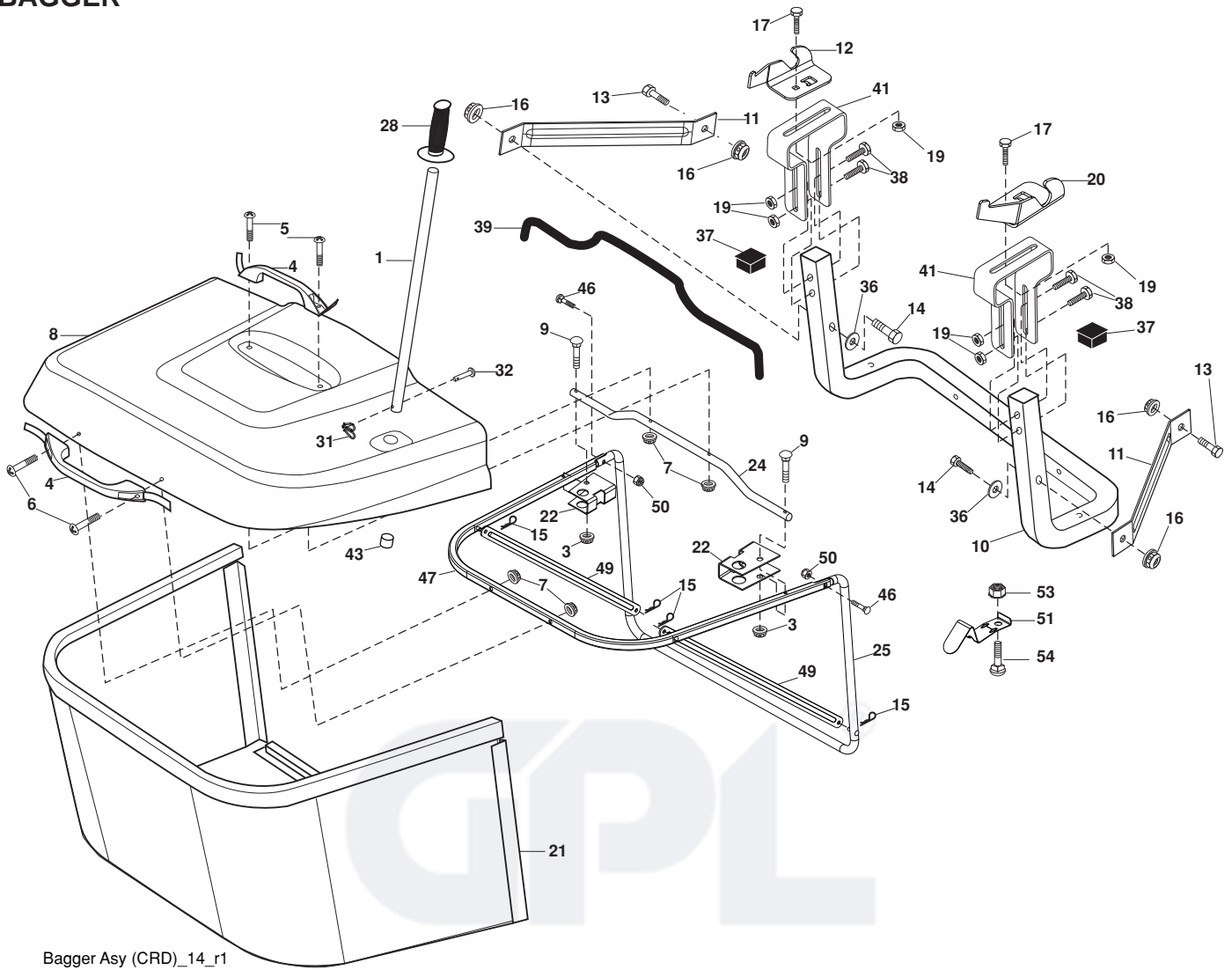

Bagger Asy (CRD)\_14\_r1

KEY NO.	PART NO.	DESCRIPTION	KEY NO.	PART NO.	DESCRIPTION
1	532 42 86-10	Tube Handle Bagger CRD	25	532 19 37-05	Tube Front Bagger CRD
3	532 12 39-76	Nut Lock 1/4 Lge. Flg. Gr. 5 Zinc	28	532 16 57-87	Grip Handle Black
4	532 16 99-16	Handle Bagger w/Lvrs. Blk. CRD	31	532 16 94-84	Retainer Clip
5	874 98 10-24	Screw Pan Head #10-24 x 1.50 Blk.	32	532 12 68-75	Rivet Rd. Hd. Drilled 3/8 Dia
6	874 98 10-32	Screw Pan Hd	36	819 13 20-12	Washer 13/32 x 1-1/4 x 12 Ga.
7	873 40 10-00	Nut Wiz Lock Hex Serr./Hd. 10-24	37	532 17 54-01	Plug Support Bagger CRD
8	532 18 25-14	Cover Bagger	38	872 01 05-20	Bolt 5/16-18 x 2-1/2
9	872 14 04-18	Bolt Carriage 1/4-20 x 2.25 d. x Gr. 5	39	532 41 62-57	Seal
10	532 18 12-82	Tube Support Bagger CRD	41	532 43 27-55	Bracket Bagger SD Electric
11	532 16 57-19	Bracket Support Upper Bag CRD	43	532 17 40-83	Plug Tubing
12	532 18 88-48	Bracket Pivot LH	46	872 11 05-10	Bolt Carr. 5/16-18 x 1-1/4 Gr. 5
13	874 76 06-12	Bolt Fin. Hex 3/8-16 unc x 3/4	47	532 19 37-04	Tube Upper Bagger
14	874 52 06-36	Bolt Carr.	49	532 19 33-05	Bar Spreader
16	873 90 06-00	Nut Lock Flg. 3/8-16 unc	50	873 80 05-00	Nut Lock Thx. w/Ins. 5/16-18 unc
15	532 12 46-70	Retainer Spring	51	532 19 99-03	Latch Spring Bagger
17	872 14 05-06	Bolt, Rdhd. Sht. Sqnk. 5/16-18 unc x 3/4	54	872 14 04-06	Bolt Carr.
19	873 90 05-00	Nut Lock Hexflange 5/16-18	53	873 51 04-00	Nut Keps Hex 1/4-20 unc
20	532 18 88-47	Bracket Pivot RH			
21	532 40 61-80	Bag Asm. CRD			
22	532 42 82-36	Bracket Side Bagger CRD			
24	532 16 57-83	Tube Pivot Bagger CRD			

**NOTE:** All component dimensions given in U.S. inches  
1 inch = 25.4 mm

GPL®

