

ILLUSTRATED PARTS LIST

MFG. ID NO. 96061031300

CUSTOMER CATALOG NO. M12597RB

PRODUCT NO. 960 61 03-13



**TRACTOR - - MODEL NO. M12597RB 96061031300, PRODUCT NO. 960 61 03-13
DECALS 27**

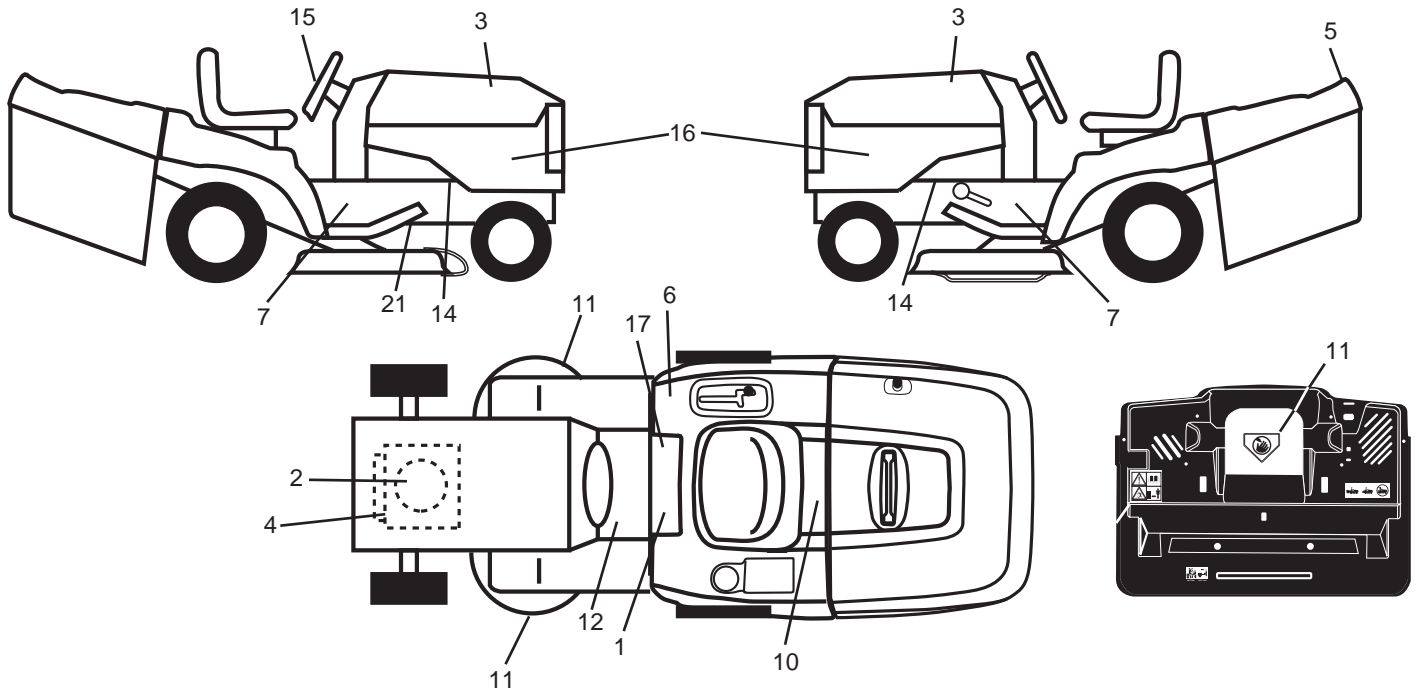

KEY NO.	PART NO.	DESCRIPTION
1	532 40 03-89	Decal, Warning Syms. CE
2	532 43 74-10	Decal, Hp Engine
3	532 43 78-24	Decal, Hood RH/LH
4	532 19 68-41	Decal, Warning Eng. Syms.
5	532 43 78-33	Decal, Fndr
6	532 18 04-32	Decal, 100 DBA/CE
7	532 18 56-51	Decal, Chassis Turbo
10	532 14 50-05	Decal, Bat Dan/Poi P/L Sym Wpn
11	532 18 21-66	Decal, Mower Cut Finger CE
12	532 15 97-37	Decal, Brake/Clutch Symbol LT
14	532 15 97-36	Decal, Chassis Hot Muffler
15	532 43 79-66	Decal, Steering Wheel

KEY NO.	PART NO.	DESCRIPTION
16	532 43 78-28	Decal, Side Panel
17	532 14 08-37	Decal, Saddle Brake Parking
21	532 16 62-86	Decal, Hex Belt Sch 92 CRD
--	532 13 83-11	Decal, Lift Handle
--	532 18 10-91	Pad Footrest LH
--	532 18 10-90	Pad Footrest RH
--	532 43 87-83	Manual Operator's (Euro)
--	532 43 87-86	Manual Operator's (Scand)
--	532 43 87-88	Manual Operator's (E-Bloc)
--	532 43 87-90	Manual Operator's (Baltic)

WHEELS & TIRES

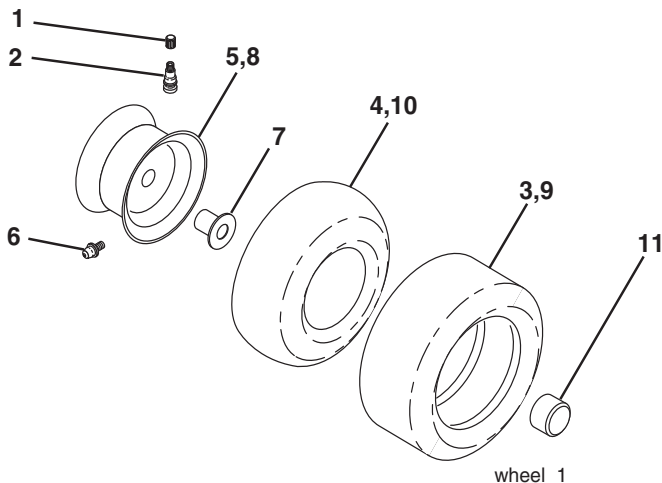

KEY NO.	PART NO.	DESCRIPTION
1	532 05 91-92	Cap Valve Tire
2	532 06 51-39	Stem Valve
3	532 10 62-22	Tire F Ts 15 x 6 0 - 6 Service
4	532 05 99-04	Tube Inner Front #35060
5	532 12 51-21	Rim Asm 6" Front Service
6	532 12 49-57	Fitting Grease
7	532 12 49-59	Bearing Flange
8	532 12 51-22	Rim Asm 8" Rear Service
9	532 13 84-68	Tire R Ts 20 x 8-8 C. Service
10	532 12 49-26	Tube Rear 9 5 x 8 Service
11	532 17 50-39	Cap Axle Blk 1 50 x 1 00
--	532 14 43-34	Sealant, Tire (10 oz. tube)

NOTE: All component dimensions given in U.S. inches
1 inch = 25.4 mm

TRACTOR - - MODEL NO. M12597RB 96061031300, PRODUCT NO. 960 61 03-13 SCHEMATIC **38**

SCH08

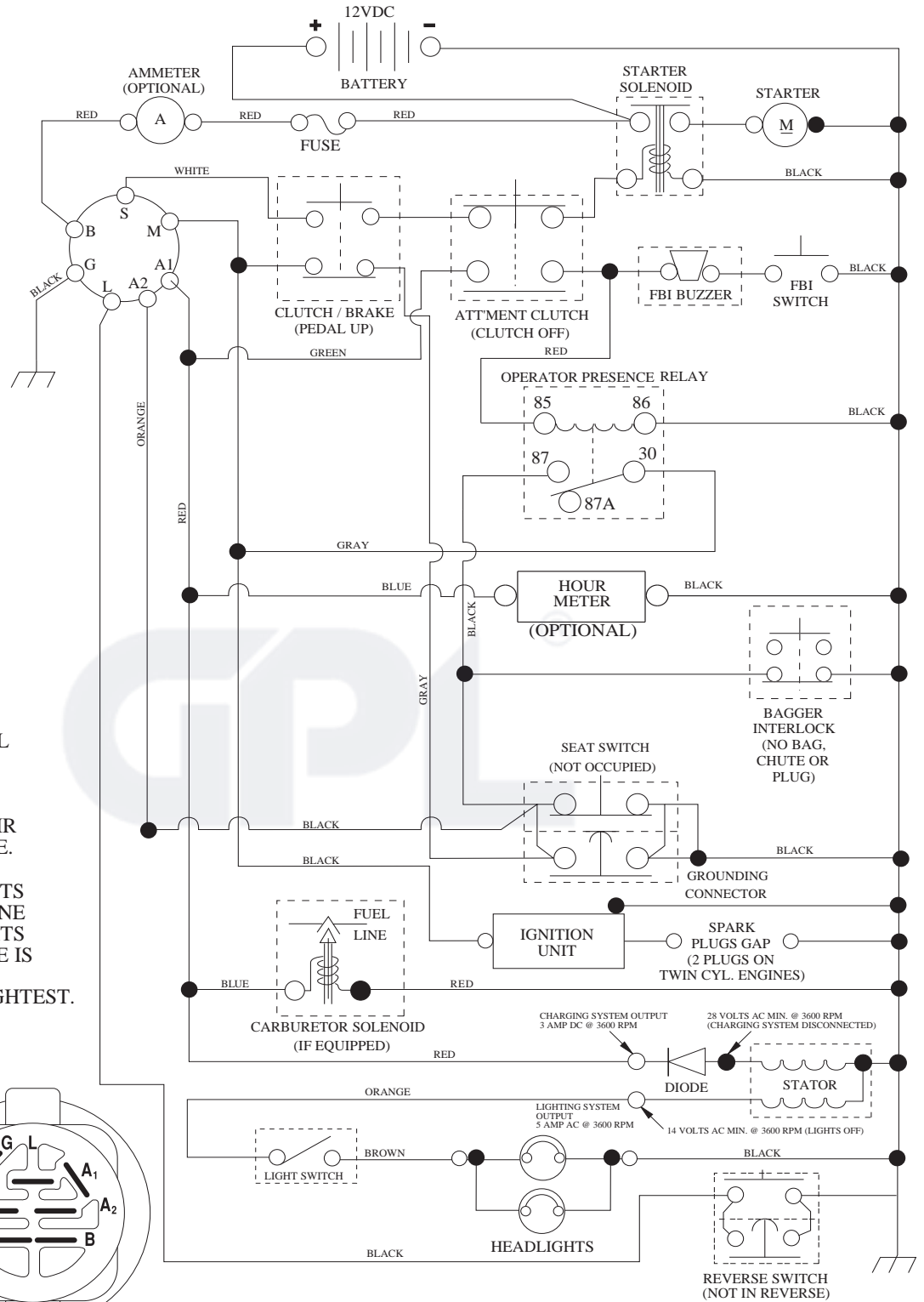

NOTE
YOUR TRACTOR IS EQUIPPED WITH A SPECIAL ALTERNATOR SYSTEM. THE LIGHTS ARE NOT CONNECTED TO THE BATTERY, BUT HAVE THEIR OWN ELECTRICAL SOURCE. BECAUSE OF THIS, THE BRIGHTNESS OF THE LIGHTS WILL CHANGE WITH ENGINE SPEED. AT IDLE THE LIGHTS WILL DIM. AS THE ENGINE IS SPEEDED UP, THE LIGHTS WILL BECOME THEIR BRIGHTEST.

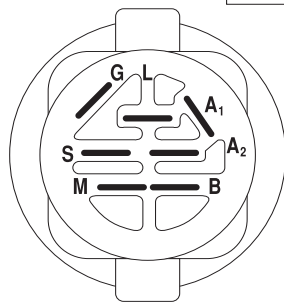

IGNITION SWITCH

POSITION	CIRCUIT	"MAKE"
OFF	M+G+A1	
RUN/OVERRIDE	B+A1	
RUN	B+A1	L+A2
START	B + S + A1	

WIRING INSULATED CLIPS

NOTE: IF WIRING INSULATED CLIPS WERE REMOVED FOR SERVICING OF UNIT, THEY SHOULD BE RE-INSTALLED TO PROPERLY SECURE YOUR WIRING.

REMOVABLE CONNECTIONS

NON-REMOVABLE CONNECTIONS

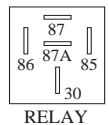

RELAY

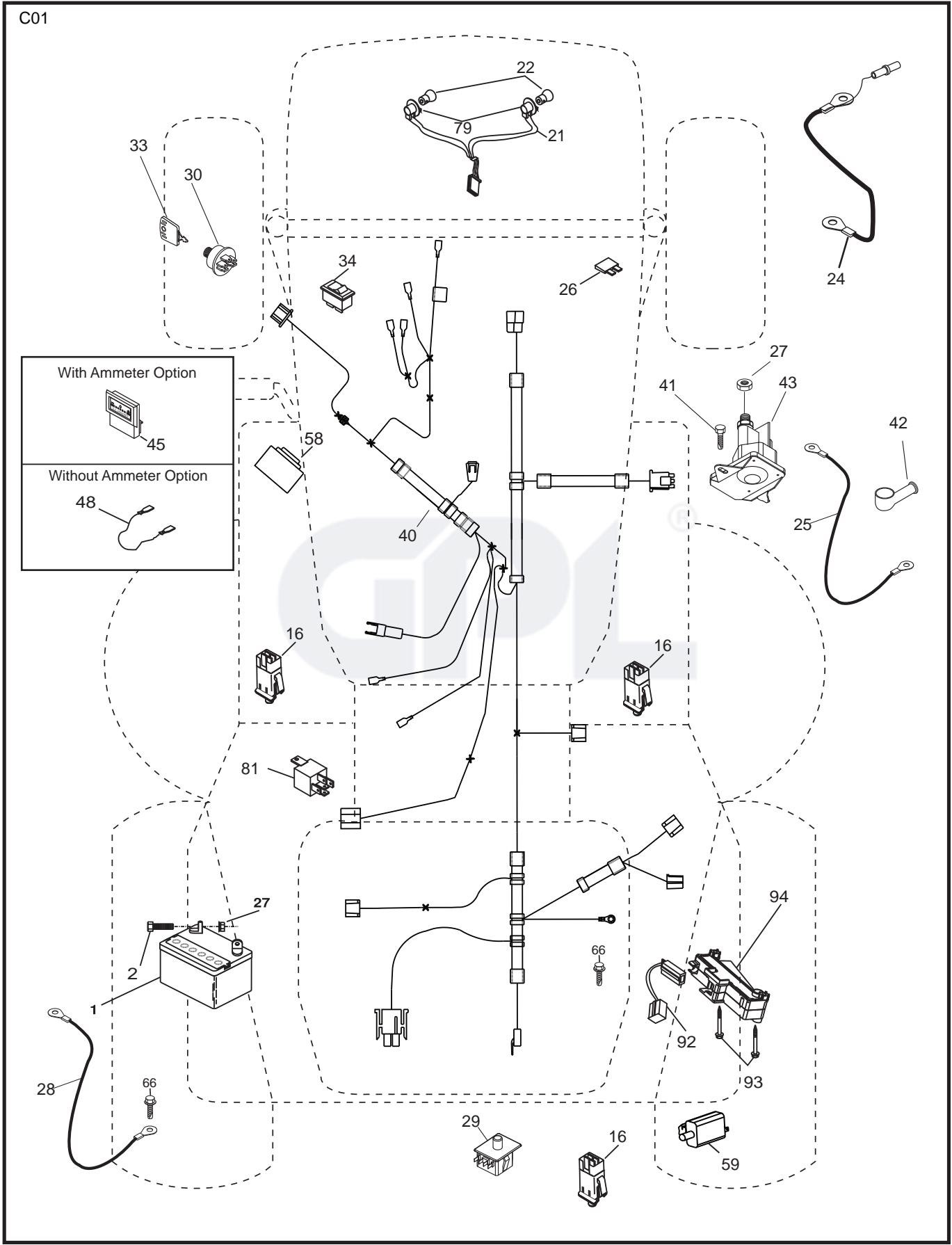

**TRACTOR - - MODEL NO. M12597RB 96061031300, PRODUCT NO. 960 61 03-13
ELECTRICAL 32**

KEY NO.	PART NO.	DESCRIPTION
1	532 16 34-65	Battery
2	874 76 04-12	Bolt Hex Hd 1/4-20 unc x 3/4
16	532 17 61-38	Switch Interlock Push-In
21	532 18 37-59	Harness Asm. Light
22	532 00 41-52	Bulb Light #1156
24	532 42 12-99	Cable Starter 6 Ga. 11" Red
25	532 16 59-87	Cable Battery Crd 56" Red
26	532 17 51-58	Fuse 20 Amp
27	873 51 04-00	Nut Keps Hex 1/4-20 unc
28	532 12 77-25	Cable Ground 6 Ga. 18" Black
29	532 19 27-49	Switch Seat
30	532 19 33-50	Switch Ignition
33	532 41 19-35	Key/Chain
34	532 11 07-12	Switch Light/Reset
40	532 19 74-36	Harness Ign
41	871 11 04-08	Bolt Flk Fin Hex 1/4-20 unc x 1/2
42	532 13 15-63	Cover Terminal Red
43	532 19 25-07	Solenoid
48	532 14 08-44	Adapter Ammeter Rectangular
58	532 16 94-19	Buzzer Crd
59	532 18 03-79	Switch FBI CRD
66	817 49 06-08	Screw Thdrol 3/8-16 x 1/2 Ty-Tt
79	532 17 52-42	Socket Asm. Bulb Twistlock
81	532 10 97-48	Relay Asm
92	532 19 66-15	Harness Pigtail
93	532 19 25-40	Screw Plastite 10-14 x 2.0
94	532 19 18-34	Module Reverse ROS

NOTE: All component dimensions given in U.S. inches
1 inch = 25.4 mm.

**TRACTOR - - MODEL NO. M12597RB 96061031300, PRODUCT NO. 960 61 03-13
CHASSIS AND ENCLOSURES 39**

KEY NO.	PART NO.	DESCRIPTION	KEY NO.	PART NO.	DESCRIPTION
1	532 17 46-20	Chassis	165	532 18 13-56	Cover Battery CRD LT
2	532 18 03-84	Drawbar	170	532 19 94-88	Backplate CRD
3	817 06 06-12	Screw 3/8-16 x .75	171	872 14 06-20	Bolt Rdhd Sqnk 3/8-16 x 2-1/2 Gr. 5
5	532 15 52-72	Bumper Hood/Dash	172	819 13 20-16	Washer 13/32 x 1-1/4 x 16 Ga.
6	532 18 44-19	Saddle	173	873 51 06-00	Nut, Keps Hex 3/8-16 unc
8	532 12 64-71	Clip Insulator 13/32 Mtg. Hole	175	532 18 82-03	Trap Door CRD
9	532 19 46-88	Dash	179	532 18 82-02	Rod Pivot FBI CRD
10	872 14 06-08	Bolt, Carriage 3/8-16 x 3/4	184	532 17 46-62	Bracket Actuator Bagger CRD
11	532 17 49-96	Panel, Dash, LH	185	532 18 11-01	Knob Rod
13	532 18 17-19	Panel, Asm. Dash RH	186	532 16 07-93	Latch Asm Multch Bagger
15	874 18 05-12	Screw, Machine, Truss Head 5/16-18 unc x 3/4	187	532 12 50-04	Nut Weld .327/.304 #10-24
16	873 51 05-00	Nut	188	819 06 12-16	Washer #10
17	532 18 27-16	Hood Assembly	189	810 07 10-00	Washer Lock #10
18	532 18 49-21	Bumper Hood	190	871 08 10-10	Screw Pan Hd Phillips 10-24 x 5/8
24	874 78 06-16	Bolt	198	532 16 89-37	Nut Push
25	819 13 13-12	Washer 13/32 x 13/16 x 12 Ga.	205	817 49 06-08	Screw 3/8-16 x 1/2
26	873 80 06-00	Nut	207	817 67 05-08	Screw THDROL 5/16-18 x 1/2
28	532 43 15-22	Grille	208	817 67 06-08	Screw Thdrol 3/8-16 x 1/2
30	532 19 73-64	Fender	209	817 00 06-12	Screw Hex Wsh Thdrol 3/8-16 x 3/4
31	532 16 51-56	Bracket, Fender Support	212	532 18 42-48	Insert Lens Reflective
33	532 18 25-07	Footrest, LH	256	532 18 13-61	Cover Fender Rack CRD
34	532 18 25-08	Footrest, RH	258	532 19 05-07	Lens Grille RH
35	872 11 06-06	Bolt	259	532 19 05-08	Lens Grille LH
37	817 49 05-08	Screw Thdrol 5/16-18 x 1/2 TYT	260	532 40 83-82	Cover Lens
38	532 18 17-48	Bracket Asm Pivot Mower Rear	261	532 40 83-95	Insert Grille
39	532 40 78-07	Bracket Pivot Laser	265	532 18 57-04	Seal Side RH Bagger
69	532 14 24-32	Screw Hex 1/4-1/2	266	532 18 57-03	Seal Side LH Bagger
89	532 19 58-09	Console	278	532 41 63-58	Screw #10 x .075 BOS Thread
145	532 40 91-67	Rod Pivot Chassis/Hood	--	532 00 54-79	Plug, Button
162	532 18 03-82	Bracket Exten Chassis LH CRD			
163	532 18 03-83	Bracket Exten Chassis RH CRD			
164	532 16 56-05	Support Battery CRD			

NOTE: All component dimensions given in U.S. inches
1 inch = 25.4 mm.

TRACTOR - - MODEL NO. M12597RB 96061031300, PRODUCT NO. 960 61 03-13
 DRIVE **40**

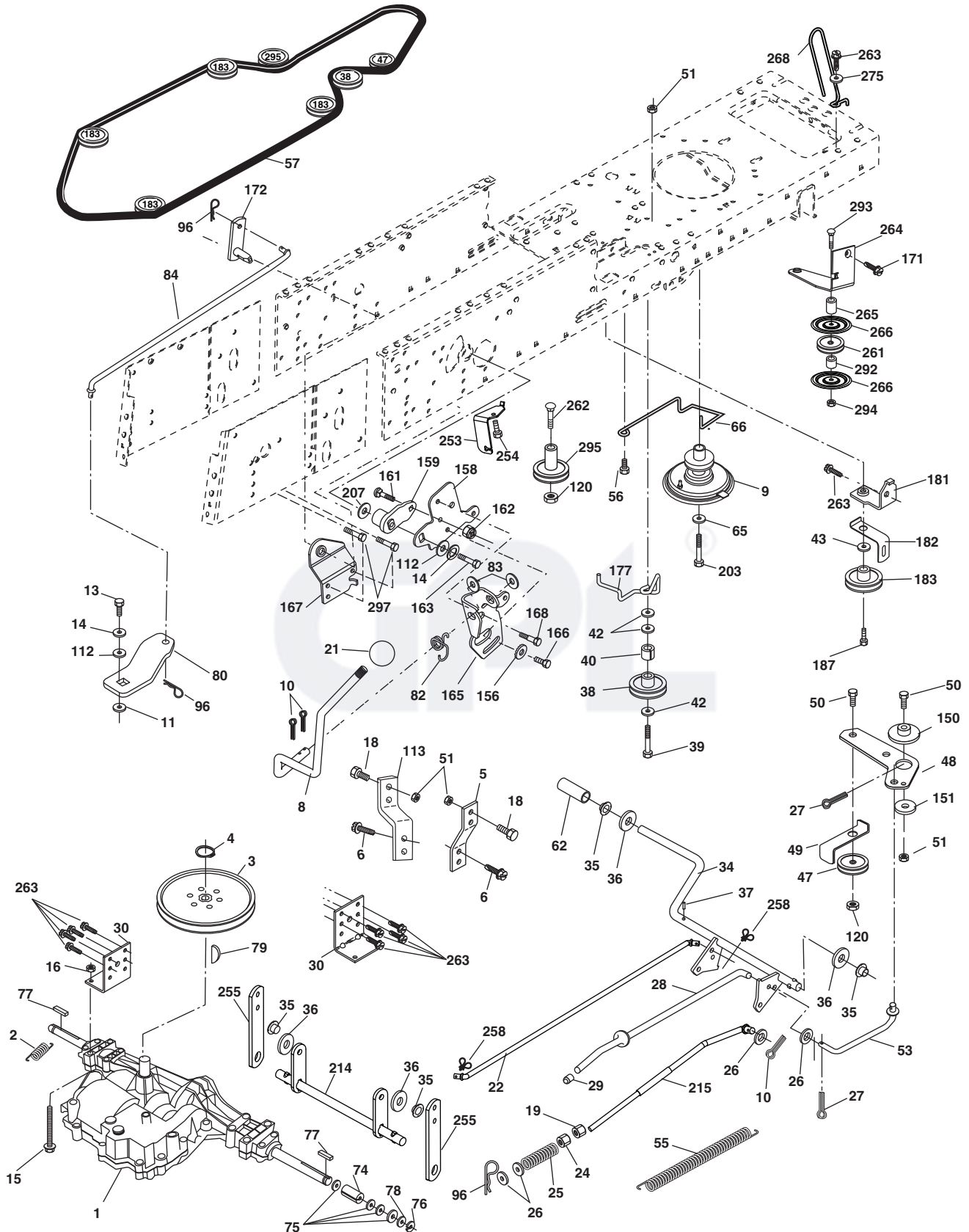

**TRACTOR - - MODEL NO. M12597RB 96061031300, PRODUCT NO. 960 61 03-13
DRIVE 40**

KEY NO.	PART NO.	DESCRIPTION	KEY NO.	PART NO.	DESCRIPTION
1	---	Peerless 206-546 (Order parts from transaxle manufacturer.)	82	532 16 57-11	Spring, Torsion
2	532 14 66-82	Spring Brake Return	83	819 17 12-16	Washer 17/32 x 3/4 x 16 Ga.
3	532 16 59-99	Pulley Transaxle	84	532 16 56-20	Link, Shift
4	812 00 00-28	Ring Retainer	96	532 12 47-88	Spring, Retainer 1"
5	532 12 15-20	Strap Torque RH	112	819 09 12-10	Washer 9/32 x 3/4 x 10 Ga.
6	817 06 05-12	Screw 5/16-18 x 3/4	113	532 12 72-85	Strap Torque LH
8	532 19 27-06	Rod, Shift Fender Adjust Lt	120	873 90 06-00	Nut Lock Flg. 3/8-16 unc
9	532 40 85-79	Clutch Asm Noram	150	532 16 58-50	Bushing, Bellcrank Grnd Dr
10	876 02 04-16	Pin, Cotter 1/8 x 1	151	819 13 32-10	Washer 13/32 x 2 x 10 Ga.
11	532 10 57-01	Washer Plate Shift	156	532 16 60-02	Washer Srrtd 5/16 ID x 1.125
13	874 55 04-12	Bolt 1/4-28 UNF Gr. 8 w/Patch	158	532 16 55-89	Bracket Shift Mount
14	810 04 04-00	Washer, Lock Hvy Helical	159	532 18 39-00	Hub Shift
15	874 49 05-44	Bolt Hex FGHD 5/16-18 x Gr. 5	161	872 14 04-06	Bolt Rdhd Sqkn 1/4-20 x 3/4 Gr. 5
16	873 80 05-00	Nut Lock Hex w/Ins 5/16-18 unc	162	873 68 04-00	Nut Crownlock 1/4-20 unc
18	874 78 06-16	Bolt Fiin Hex 3/8-16 unc x 1 Gr. 5	163	874 78 04-16	Bolt Hex Fin 1/4-20 unc x 1 Gr. 5
19	873 80 06-00	Nut Lock Hex w/Ins 3/8-16 unc	165	532 16 56-23	Bracket Pivot Lever
21	532 10 69-33	Knob	166	817 49 05-10	Screw 5/16-18 x 5/8
22	532 17 56-07	Rod Brake Main	167	532 16 55-88	Bracket Support Shift CRD
24	873 35 06-00	Nut Hex Jam 3/8-16 unc	168	532 16 54-92	Bolt Shoulder 5/16-18 x .561
25	532 10 68-88	Spring, Rod, Brake	171	817 49 06-08	Screw Thdrol 3/8-16 x 1/2 Ty-Tt
26	819 13 13-16	Washer 13/32 x 13/16 x 16 Ga.	172	532 16 56-35	Shaft Asm Shifter Frt CRD
27	876 02 04-12	Pin, Cotter 1/8 x 3/4	177	532 16 59-32	Keeper Flat Idler 3.06" CRD
28	532 17 57-65	Rod, Parking Brake	181	532 18 02-11	Bracket Idler Ground Drive CRD
29	532 07 16-73	Cap, Parking Brake	182	532 18 26-82	Keeper Belt 2.5" Od V-Idler CRD
30	532 16 95-92	Bracket, Mfg. Transaxle	183	532 19 95-34	Pulley V-Idler CRD
34	532 17 55-78	Shaft, Asm Pedal Foot CRD	187	817 58 05-20	Screw Thdrol 5/16-18 x 1.25
35	532 12 01-83	Bearing, Nylon	203	871 17 07-80	Bolt Hex 7/16-20 x 5
36	819 21 16-16	Washer 21/32 x 1 x 16 Ga.	207	532 16 98-45	Washer Nylon Rear
37	532 12 49-63	Pin, Roll 3/16 x 1"	214	532 17 56-09	Shaft Asm. Brake
38	532 16 59-36	Pulley Flat Composite 3.06"	215	532 41 01-42	Rod Brake Hydro
39	874 76 06-44	Bolt Fin Hex 3/8-16 unc x 2-3/4	253	532 17 50-28	Bracket Cable Chassis
40	532 12 49-65	Spacer, Split 395 x 59 Bzp	254	817 00 06-16	Screw 3/8-16 x 1
42	819 13 13-12	Washer 13/32 x 13/16 x 12 Ga.	255	532 17 56-08	Brace Shaft Brake Mtg.
43	819 11 10-12	Washer 11/32 x 5/8 x 12 Ga.	258	532 17 80-62	Clip Retainer
47	532 12 77-83	Pulley, Idler, V Groove Plastic	261	532 13 14-94	Pulley Idler
48	532 15 44-07	Bellcrank Clutch Grnd Drv	262	872 11 06-22	Bolt Carr. 3/8-16 x 2-3/4 Gr. 5
49	532 12 32-05	Retainer, Belt Style Spring	263	817 00 06-12	Screw 3/8-16 x 3/4
50	872 11 06-12	Bolt Carr. Sh. 3/8-16 x 1-1/2 Gr. 5	264	532 43 11-74	Bracket Idler Chassis
51	873 68 06-00	Nut, Crownlock 3/8-16 unc	265	532 42 69-13	Spacer Idler Chassis
53	532 19 96-52	Link, Clutch 7.66	266	532 18 20-61	Shield Idler Mower
55	532 10 57-09	Spring, Return, Clutch	268	532 18 24-02	Guard Muffler RH
56	817 06 06-20	Screw 3/8-16 x 1-1/4	275	819 13 16-14	Washer 13/32 x 1 x 14 Ga.
57	532 16 56-31	V-Belt	292	532 40 02-71	Spacer Noram
62	532 12 48-72	Cover, Pedal	293	872 14 06-28	Bolt 3/8-16 x 3-1/2
65	810 04 07-00	Washer	294	532 19 70-33	Nut 3/8-16
66	532 15 47-78	Keeper, Belt Engine F-Proof	295	532 17 91-14	Pulley Idler Composite
74	532 13 70-57	Spacer, Split	297	817 49 06-10	Screw 3/8-16 x 5/8
75	532 12 17-49	Washer 25/32 x 1-1/4 x 16 Ga.			
76	812 00 00-01	Ring, E			
77	532 12 35-83	Key, Square			
78	532 12 17-48	Washer 25/32 x 1-5/8 x 16 Ga.			
79	532 12 50-96	Key Woodruff			
80	532 14 50-90	Lever			

NOTE: All component dimensions given in U.S. inches
1 inch = 25.4 mm

TRACTOR - - MODEL NO. M12597RB 96061031300, PRODUCT NO. 960 61 03-13
STEERING ASSEMBLY **41**

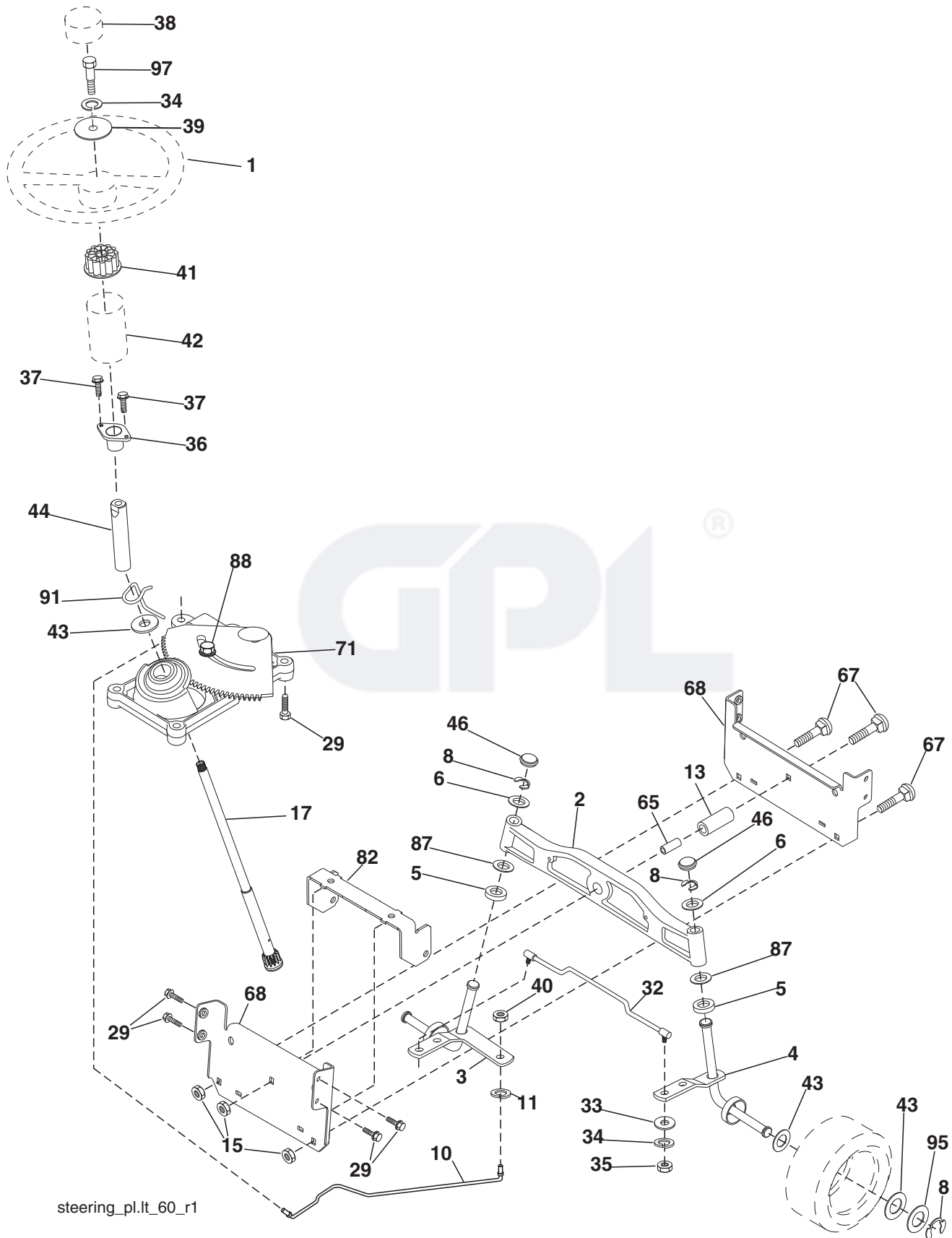

TRACTOR - - MODEL NO. M12597RB 96061031300, PRODUCT NO. 960 61 03-13
STEERING ASSEMBLY 41

KEY NO.	PART NO.	DESCRIPTION
1	532 42 45-43	Steering Wheel
2	532 18 47-06	Cast Iron Axle Assembly
3	532 16 98-40	Spindle Assembly, LH
4	532 16 98-39	Spindle Assembly, RH
5	532 12 49-31	Bearing, Race, Thrust, Hardened
6	532 12 17-48	Washer 25/32 x 1-5/8 x 16 Ga.
8	812 00 00-29	Ring, Clip
10	532 17 51-21	Link, Drag
11	810 04 06-00	Washer, Lock
13	532 13 65-18	Spacer Brg Axle Front
15	873 90 06-00	Nut, Lock Flg. 3/8-16 unc
17	532 19 07-53	Shaft Assembly, Steering
29	817 00 06-12	Screw, 3/8-16 x 3/4
32	532 17 01-62	Rod, Tie
33	819 11 12-16	Washer 11/32 x 3/4 x 16 Ga.
34	810 04 05-00	Washer Lock Hvy Hlcl Spr 5/16
35	873 54 05-00	Nut Crownlock 5/16-24 unf
36	532 15 50-99	Bushing, Steering
37	532 15 29-27	Screw TT #10-32 x 5 x 3/8 Flange
38	532 42 41-47	Cap Wheel Steering
39	819 11-38-12	Washer 11/32 ID x 2-3/8 OD 12 Ga.
40	873 54 06-00	Nut Crownlock 3/8-24
41	532 18 67-37	Adapter, Steering Wheel
42	532 16 96-33	Boot, Steering Dash P/L Mtl
43	532 12 17-49	Washer 25/32 x 1-1/4 x 16 Ga.
44	532 19 07-52	Extension Steering
46	532 12 12-32	Cap, Spindle
65	532 41 47-36	Spacer Brace Axle
67	872 11 06-18	Bolt Rdhd Sq 3/8-16 unc x 2-1/4
71	532 17 51-46	Steering Asm.
68	532 16 98-27	Brace Axle
82	532 19 99-78	Bracket Susp Chassis Front
87	532 17 39-66	Washer Flat .781 x 1-1/2 x .14
88	532 17 51-18	Bolt Shoulder 7/16-20 unc
91	532 17 55-53	Clip Steering
95	532 18 89-67	Washer Harden .793 x 1.637 x 060
97	532 42 89-82	Bolt 5/16-18 x 4 w/Patch

NOTE: All component dimensions given in U.S. inches
1 inch = 25.4 mm.

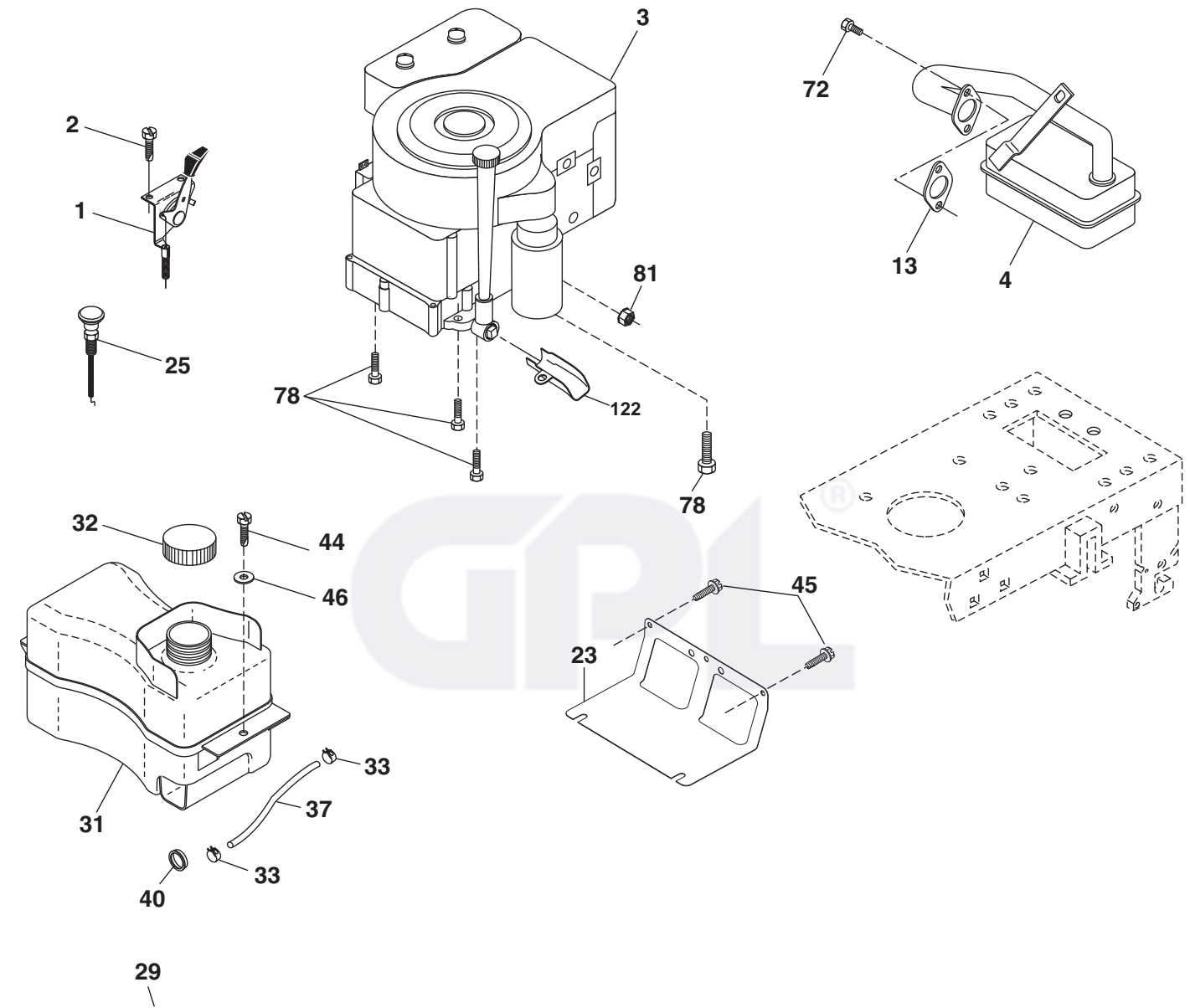

OPTIONAL EQUIPMENT
Spark Arrester

engine-CRD_bs_19

**TRACTOR - - MODEL NO. M12597RB 96061031300, PRODUCT NO. 960 61 03-13
ENGINE 24**

KEY NO.	PART NO.	DESCRIPTION
1	532 17 05-51	Control Throt/Ch Flag
2	817 72 04-08	Screw Hex Thd Cut 1/4-20 x 1/2
3	- - - - -	Engine B&S 219807-1402-B1 (Order parts from engine manufacturer.)
4	532 17 97-58	Muffler
13	532 16 52-91	Gasket
23	532 16 98-37	Shield Browning/Debris Guard
25	532 19 06-95	Control Choke
29	532 13 71-80	Arrester Spark
31	532 40 75-16	Tank Fuel
32	532 43 02-20	Cap Fuel
33	532 12 34-87	Clamp Hose Blk
37	532 13 70-40	Line Fuel 20"
40	532 12 40-28	Bushing Snap
44	817 67 04-12	Screw Hexwsh Thdrol 1/4-20 x 3/4
45	817 00 06-12	Screw Hexwsh Thdr 3/8-16 x 3/4
46	819 09 14-16	Washer 9/32 x 7/8 x 16 Ga.
72	532 19 23-34	Screw Socket Hd 5/16-18 x .75
78	817 06 06-20	Screw 3/8-16 x 1-1/4
81	873 51 04-00	Nut Keps 1/4-20 unc
122	532 42 19-22	Extension Drain Oil

NOTE: All component dimensions given in U.S. inches
1 inch = 25.4 mm

Engine Power Rating Information

The gross power rating for individual gas engine models is labeled in accordance with SAE (Society of Automotive Engineers) code J1940 (Small Engine Power & Torque Rating Procedure), and rating performance has been obtained and corrected in accordance with SAE J1995 (Revision 2002-05). Torque values are derived at 3060 RPM; horsepower values are derived at 3600 RPM. Actual gross engine power will be lower and is affected by, among other things, ambient operating conditions and engine-to-engine variability. Given both the wide array of products on which engines are placed and the variety of environmental issues applicable to operating the equipment, the gas engine will not develop the rated gross power when used in a given piece of power equipment (actual "on-site" or net power). This difference is due to a variety of factors including, but not limited to, accessories (air cleaner, exhaust, charging, cooling, carburetor, fuel pump, etc.), application limitations, ambient operating conditions (temperature, humidity, altitude), and engine-to-engine variability. Due to manufacturing and capacity limitations, Briggs & Stratton may substitute an engine of higher rated power for this Series engine.

TRACTOR - - MODEL NO. M12597RB 96061031300, PRODUCT NO. 960 61 03-13
SEAT ASSEMBLY 42

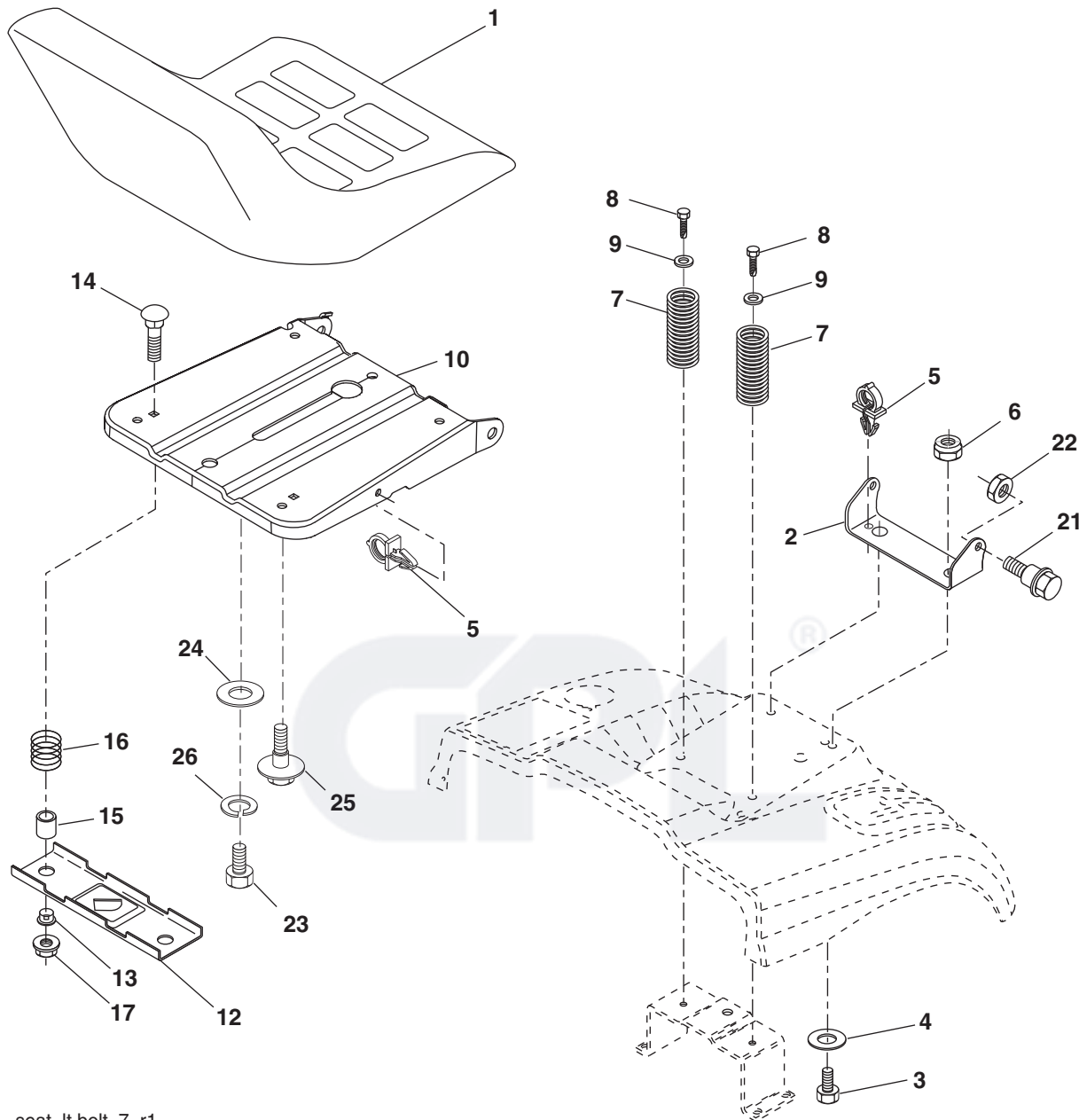

seat_lt.bolt_7_r1

KEY NO.	PART NO.	DESCRIPTION
1	532 40 10-42	Seat
2	532 14 05-51	Bracket Pnt Pivot Seat (Blk)
3	871 11 06-16	Bolt Fin Hex 3/8-16 unc x 1
4	819 13 16-10	Washer Flat 13/32 x 1 x 10 Ga.
5	532 14 50-06	Clip Push In Hinged
6	873 80 06-00	Nut Lock Hex 3/8-16 unc
7	532 12 41-81	Spring Seat Cprsn 2 250 Blk Zi
8	817 00 06-16	Screw 3/8-16 x 1-1/2
9	819 13 16-14	Washer 13/32 x 1 x 14 Ga.
10	532 19 55-30	Pan Pnt Seat (Blk)
12	532 17 46-48	Bracket Pnt Mounting Switch
13	532 12 12-48	Bushing Snap Blk Nyl 50 Id
14	872 05 04-12	Bolt Rdhd Sht Nk 1/4-20 x 1-1/2

KEY NO.	PART NO.	DESCRIPTION
15	532 13 43-00	Spacer Split
16	532 12 12-50	Spring Cprsn
17	532 12 39-76	Nut Lock 1/4 Lge Flg Gr. 5 Zinc
21	532 17 18-52	Bolt Shoulder 5/16-18 unc-2A
22	873 80 05-00	Nut Hex Lock w/Ins 5/16-18
23	871 11 08-14	Bolt Hex
24	819 17 19-12	Washer 17/32 x 1-3/16 x 12 Ga.
25	532 12 70-18	Bolt Shoulder 5/16-18 x .62
26	810 04 08-00	Washer Lock

NOTE: All component dimensions given in U.S. inches
 1 inch = 25.4 mm

TRACTOR - - MODEL NO. M12597RB 96061031300, PRODUCT NO. 960 61 03-13
MOWER LIFT 45

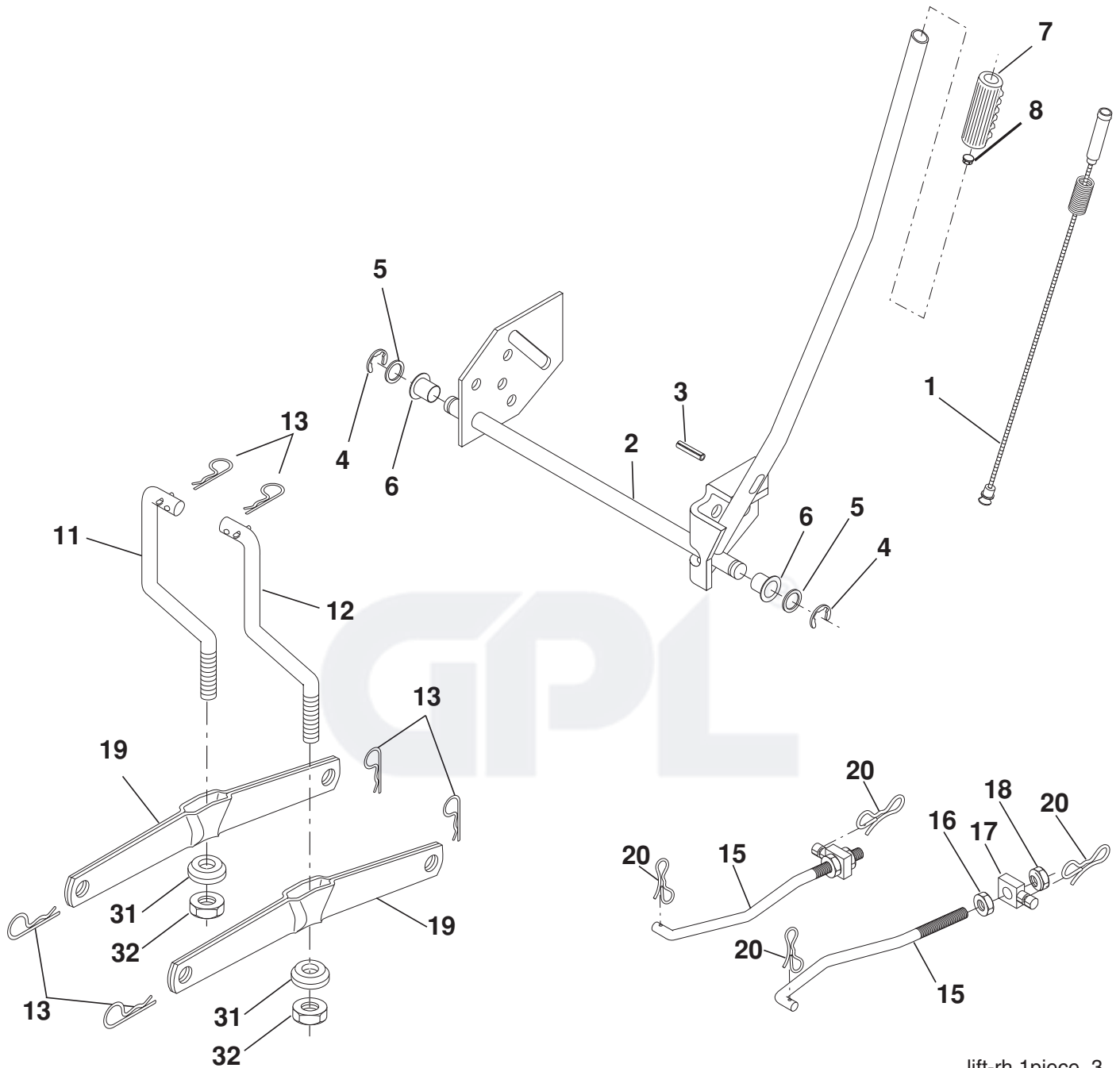

lift-rh.1piece_3

KEY NO.	PART NO.	DESCRIPTION
1	532 40 49-81	Plunger Asm Lift Lever
2	532 15 94-71	Shaft Asm. Lift
3	532 10 57-67	Pin Groove
4	812 00 00-02	E Ring #5133-62
5	819 21 16-21	Washer 21/32 x 1 x 21 Ga.
6	532 12 01-83	Bearing Nylon
7	532 10 94-13	Grip Handle Bicycle
8	532 12 45-26	Button Plunger Black
11	532 13 98-65	Link Asm Lift LH
12	532 13 98-66	Link Asm Lift RH
13	532 12 46-70	Retainer Spring

KEY NO.	PART NO.	DESCRIPTION
15	532 17 32-88	Link Front
16	873 35 08-00	Nut Jam Hex 1/2-13 unc
17	532 17 56-89	Trunnion Blk Zinc
18	873 80 08-00	Nut Lock w/Wsh 1/2-13 unc
19	532 13 98-68	Arm Suspension Mower
20	532 19 42-09	Pin Cotter 7/16 Bowtie Lock
31	532 16 98-65	Bearing, Pvt. Lift.
32	873 54 06-00	Nut Crownlock 3/8-24

NOTE: All component dimensions given in U.S. inches
 1 inch = 25.4 mm

TRACTOR - - MODEL NO. M12597RB 96061031300, PRODUCT NO. 960 61 03-13
MOWER DECK 44

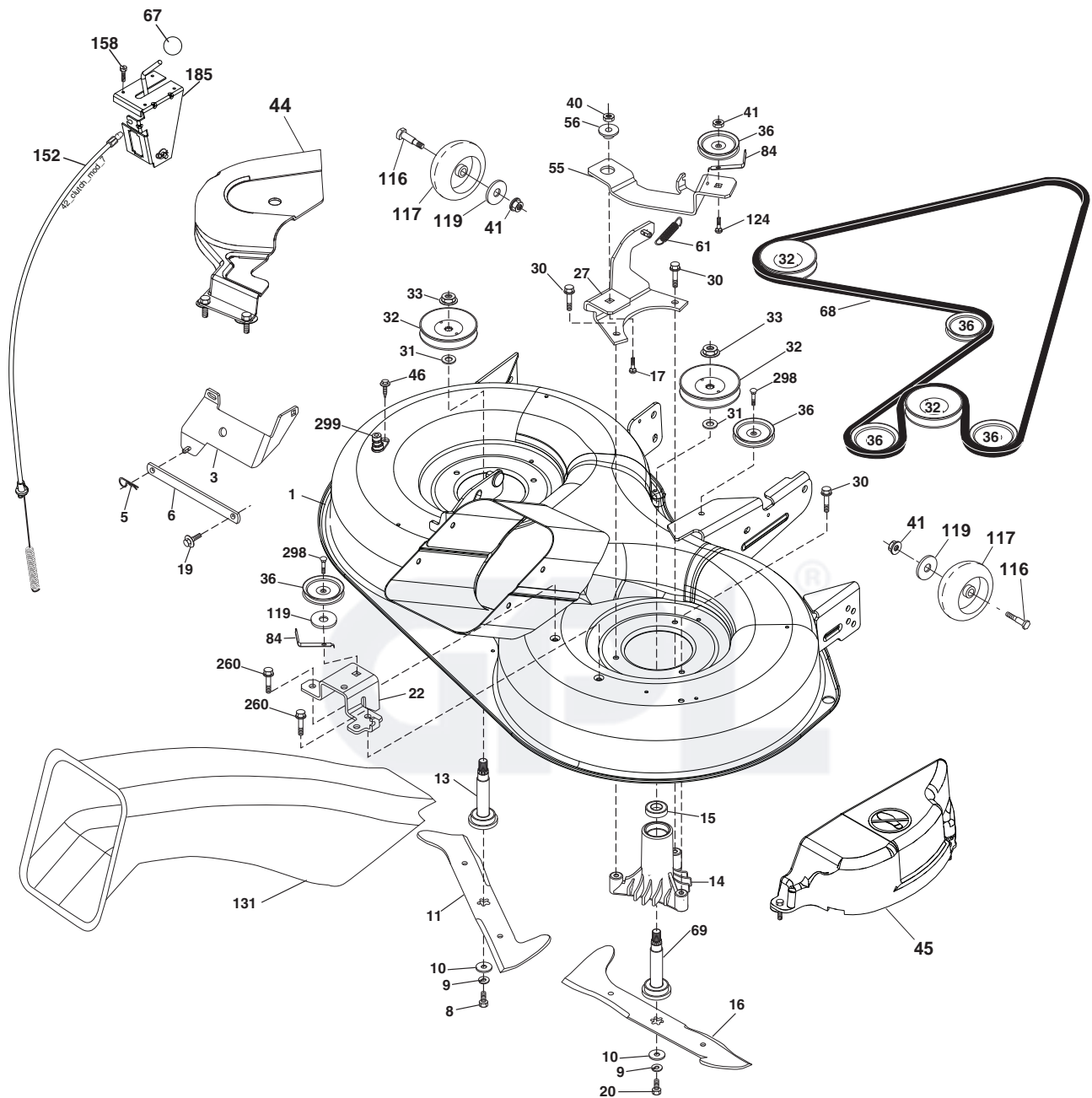

Deck-CRD_97cm_Elect_1_r5

**TRACTOR - - MODEL NO. M12597RB 96061031300, PRODUCT NO. 960 61 03-13
MOWER DECK 44**

KEY NO.	PART NO.	DESCRIPTION	KEY NO.	PART NO.	DESCRIPTION
1	532 42 91-21	Housing Asm. Mower	56	532 16 57-23	Spacer Retainer Mower
3	532 43 18-64	Bracket Asm. S-Bar Chass	61	532 19 94-86	Spring Tension Belt
5	532 12 46-70	Retainer Spring	67	532 10 69-32	Knob Rd. 3/8-16
6	532 16 55-57	Bar Sway	68	532 42 95-32	V Belt Mower
8	532 18 17-12	Bolt 3/8-24 x 1.25 Gr. 8 Patched	69	532 16 54-82	Shaft Asm w/Lwr Brg RH Thd
9	810 03 06-00	Washer Lock Hvy 3/8 Unplated	84	532 15 60-85	Keeper Belt Idler
10	532 14 02-96	Washer Hard Blade Mower Vented	116	532 19 34-06	Bolt Shoulder
11	532 42 79-84	Blade 3-1 LH	117	532 17 48-73	Wheel Gauge
13	532 13 76-45	Shaft Asm. w/Lower Bearing	119	819 13 20-12	Washer 13/32 x 1-1/4 x 12 Ga.
14	532 12 87-74	Housing Mandrel Vented (Machd)	124	872 11 06-12	Bolt Carr Sh 3/8-16 x 1-1/2 Gr. 5
15	532 11 04-85	Bearing Ball Mandrel	131	532 16 56-61	Chute Bagger
16	532 42 79-85	Blade 3-1 RH	152	532 17 60-74	Cable Clutch
17	872 14 06-10	Bolt Carriage 3/8-16 x 1-1/4	158	817 72 04-08	Screw Thd. Cut 1/4-20 x 1/2
19	532 13 28-27	Bolt Shoulder 5/16-18 Thd Form	185	532 18 82-34	Head Asm. Cable Clutch
20	532 18 17-13	Bolt 3/8-24 x 1.25 Gr. 8 Ptch Lhthd	260	817 67 06-08	Screw 3/8-16 x 1/2
22	532 43 11-69	Bracket Idler Sprt 92 CRD	298	817 49 06-28	Screw 3/8-16 x 1-3/4
27	532 42 79-81	Bracket Asm. Susp. Rear RH	299	532 41 55-98	Port Washout
30	532 17 39-84	Screw Thd Rolling	---	532 18 18-57	Mandrel Assembly (Includes hous- ing, shaft assembly, and bearing only - pulley/nut/washer and blade bolt/washers not included)
31	532 18 76-90	Washer Spacer Mower Vented			
32	532 15 35-32	Mandrel Pulleys			
33	532 40 02-34	Nut Flg Top Lock			
36	532 14 67-63	Pulley Idler V-Groove Dim 4.25	---	532 18 18-58	Mandrel Asm CRDLH Threads SVC
40	873 68 06-00	Nut Crownlock 3/8-16 unc	---	532 43 34-84	Replacement Mower, Complete (Std. Deck - Order separately gauge wheel components key nos. 116-119)
41	873 90 06-00	Nut Lock Flg. 3/8-16 unc			
44	532 43 49-46	Cover Mandrel LH			
45	532 44 14-79	Cover Mandrel RH			
46	532 13 77-29	Screw			
55	532 19 94-98	Arm Idler			

NOTE: All component dimensions given in U.S. inches
1 inch = 25.4 mm

TRACTOR - - MODEL NO. M12597RB 96061031300, PRODUCT NO. 960 61 03-13
BAGGER 46

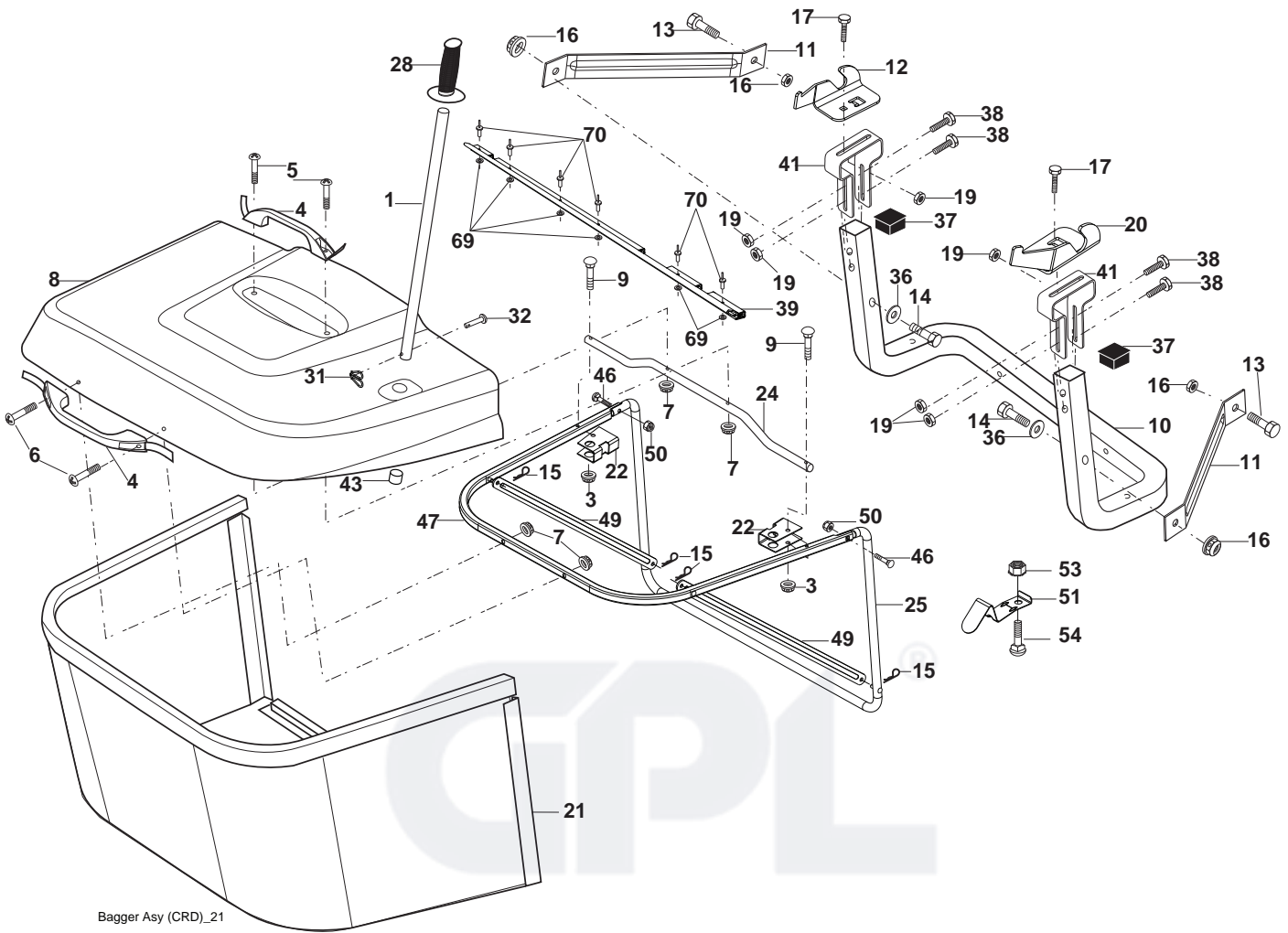

Bagger Asy (CRD)_21

KEY NO.	PART NO.	DESCRIPTION	KEY NO.	PART NO.	DESCRIPTION
1	532 42 86-10	Tube Handle Bagger CRD	28	532 16 57-87	Grip Handle Black
3	532 12 39-76	Nut Lock 1/4 Lge Flg Gr. 5 Zinc	31	532 16 94-84	Retainer Clip
4	532 16 99-16	Handle Bagger w/Lvrs Gr. 5 Zinc	32	532 12 68-75	Rivet Rd Hd Drilled 3/8 Dia
5	874 98 10-24	Screw Pan Head #10-24 x 1.50 Blk	36	819 13 20-12	Washer 13/32 x 1-1/4 x 12 Ga.
6	874 98 10-32	Screw Pan Hd	37	532 17 54-01	Plug Support Bagger CRD
7	873 40 10-00	Nut Wiz Lock Hex Serr/Hd #10-24	38	872 01 05-20	Bolt 5/16-18 x 2-1/2
8	532 43 69-33	Cover Bagger	39	532 41 62-57	Seal Trim 37"
9	872 14 04-18	Bolt Carriage 1/4-20 x 2.25d x Gr. 5	41	532 43 27-55	Bracket Vert Adj Bagger CRD
10	532 18 12-82	Tube Support Bagger CRD	43	532 17 40-83	Plug Tubing End
11	532 16 57-19	Bracket Support Upper Bag CRD	46	872 11 05-10	Bolt Carr. 5/16-18 x 1-1/4 Gr. 5
12	532 18 88-48	Bracket Pivot LH	47	532 19 37-04	Tube Upper Bagger
13	874 76 06-12	Bolt Fin Hex 3/8-16 unc 3/4	49	532 19 33-05	Bar Spreader Bagger
14	874 52 06-36	Bolt Fin Hex 3/8-16 x 2 x 1/4 Gr. 5	50	873 80 05-00	Nut Lock Hex w/Insert 5/16-18 unc
15	532 12 46-70	Retainer Spring	51	532 19 99-03	Latch Spring Bagger
16	873 90 06-00	Nut Lock Flg 3/8-16 unc	53	873 51 04-00	Nut Keps Hex 1/4-20 unc
17	872 14 05-06	Bolt Rdhd Sht Sqnk 5/16-18 unc x 3/4	54	872 14 04-06	Bolt RDHD SQNK 1/4-20 x 3/4 Gr. 5
19	873 90 05-00	Nut Lock Hex Flange 5/16-18	69	532 43 56-11	Washer .125
20	532 18 88-47	Bracket Pivot RH	70	532 43 56-03	Rivet Pop .125 x .750
21	532 40 61-80	Bag Asm CRD			
22	532 42 82-36	Bracket Side Bagger CRD			
24	532 16 57-83	Tube Pivot Bagger CRD			
25	532 19 37-05	Tube Front Bagger CRD			

NOTE: All component dimensions given in U.S. inches
 1 inch = 25.4 mm

GPL[®]