

REPAIR PARTS MANUAL
MODEL NO. YT46 (96043019700)
LAWN TRACTOR

Jonsered®

HOW TO USE THIS MANUAL

This manual is designed to provide the customer with a means to identify the parts on his/her tractor when ordering repair parts. The illustrations may or may not represent the actual assemblies; therefore, it is not recommended to use this manual as a guide to assemble or disassemble the tractor. Some hardware and parts are drawn larger in order to more readily identify them.

Each tractor has its own model number.

The model number for your tractor can be found on the fender under the seat.

When ordering parts, always give the following information:

- Product - "TRACTOR"
- MODEL NUMBER - "YT46" (96043019700)"
- Part Number
- Part Description

TABLE OF CONTENTS

SCHEMATIC	3
ELECTRICAL.....	4-5
CHASSIS	6-7
DRIVE.....	8-9
ENGINE.....	10-11
STEERING	12-13
MOWER DECK	14-15
MOWER LIFT.....	16
SEAT	17
DECALS.....	18

TRACTOR - MODEL NO. YT46 (96043019700), PRODUCT NO. 960 43 01-97 SCHEMATIC

SCH11

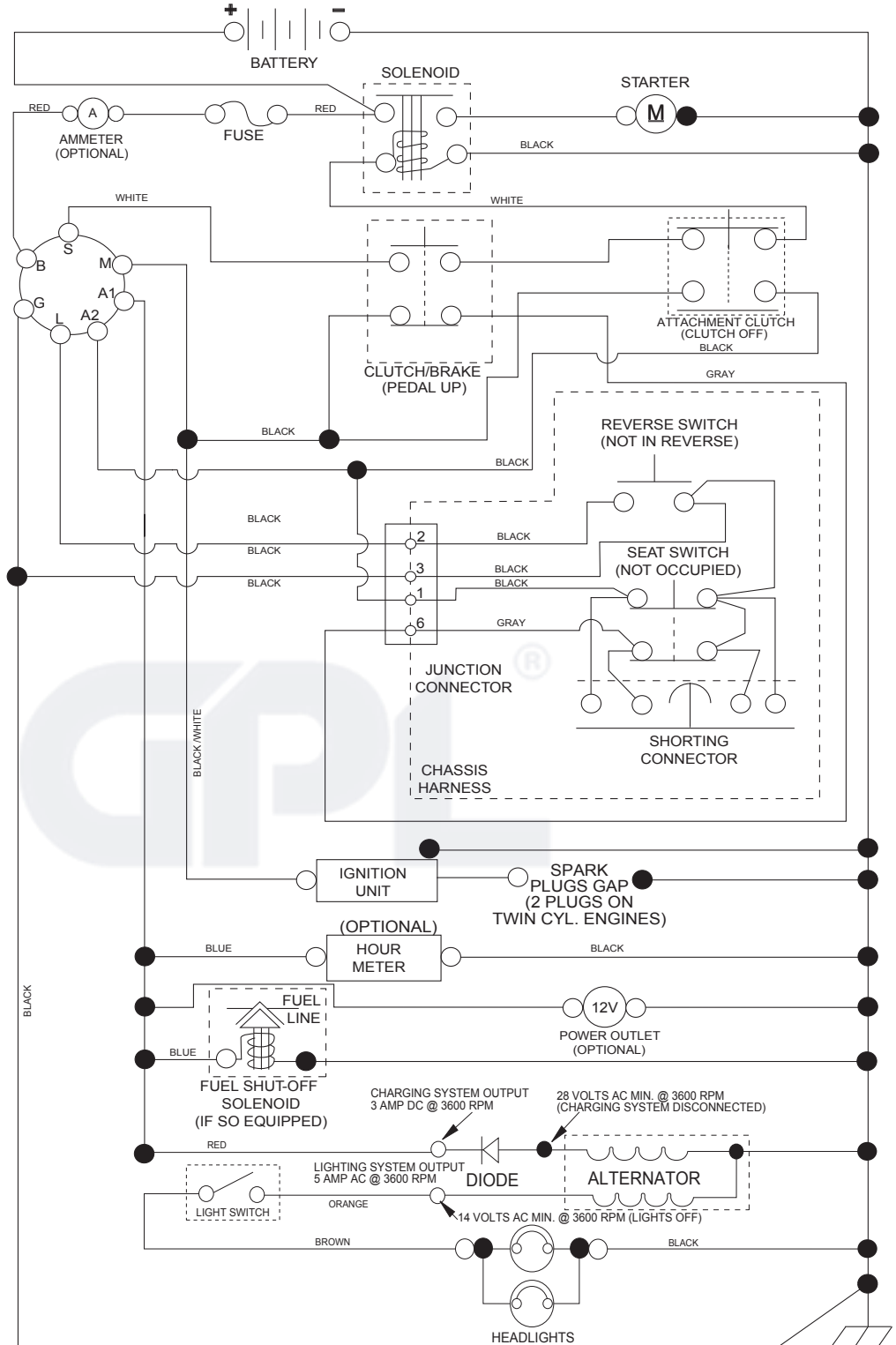

NOTE
YOUR TRACTOR IS EQUIPPED WITH A SPECIAL ALTERNATOR SYSTEM. THE LIGHTS ARE NOT CONNECTED TO THE BATTERY, BUT HAVE THEIR OWN ELECTRICAL SOURCE. BECAUSE OF THIS, THE BRIGHTNESS OF THE LIGHTS WILL CHANGE WITH ENGINE SPEED. AT IDLE THE LIGHTS WILL DIM. AS THE ENGINE IS SPEEDED UP, THE LIGHTS WILL BECOME THEIR BRIGHTEST.

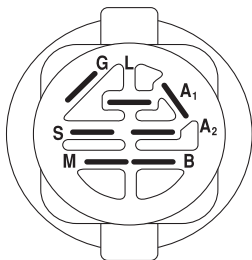

IGNITION SWITCH

POSITION	CIRCUIT "MAKE"
OFF	M+G+A1
RUN/OVERRIDE	B+A1
RUN	B+A1 L+A2
START	B+S+A1

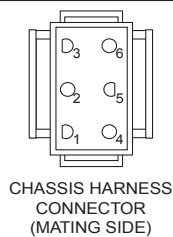

CHASSIS HARNESS CONNECTOR (MATING SIDE)

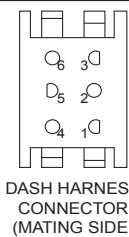

DASH HARNESS CONNECTOR (MATING SIDE)

WIRING INSULATED CLIPS
NOTE: IF WIRING INSULATED CLIPS WERE REMOVED FOR SERVICING OF UNIT, THEY SHOULD BE RE-INSTALLED TO PROPERLY SECURE YOUR WIRING.

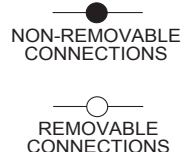

TRACTOR - MODEL NO. YT46 (96043019700), PRODUCT NO. 960 43 01-97
ELECTRICAL

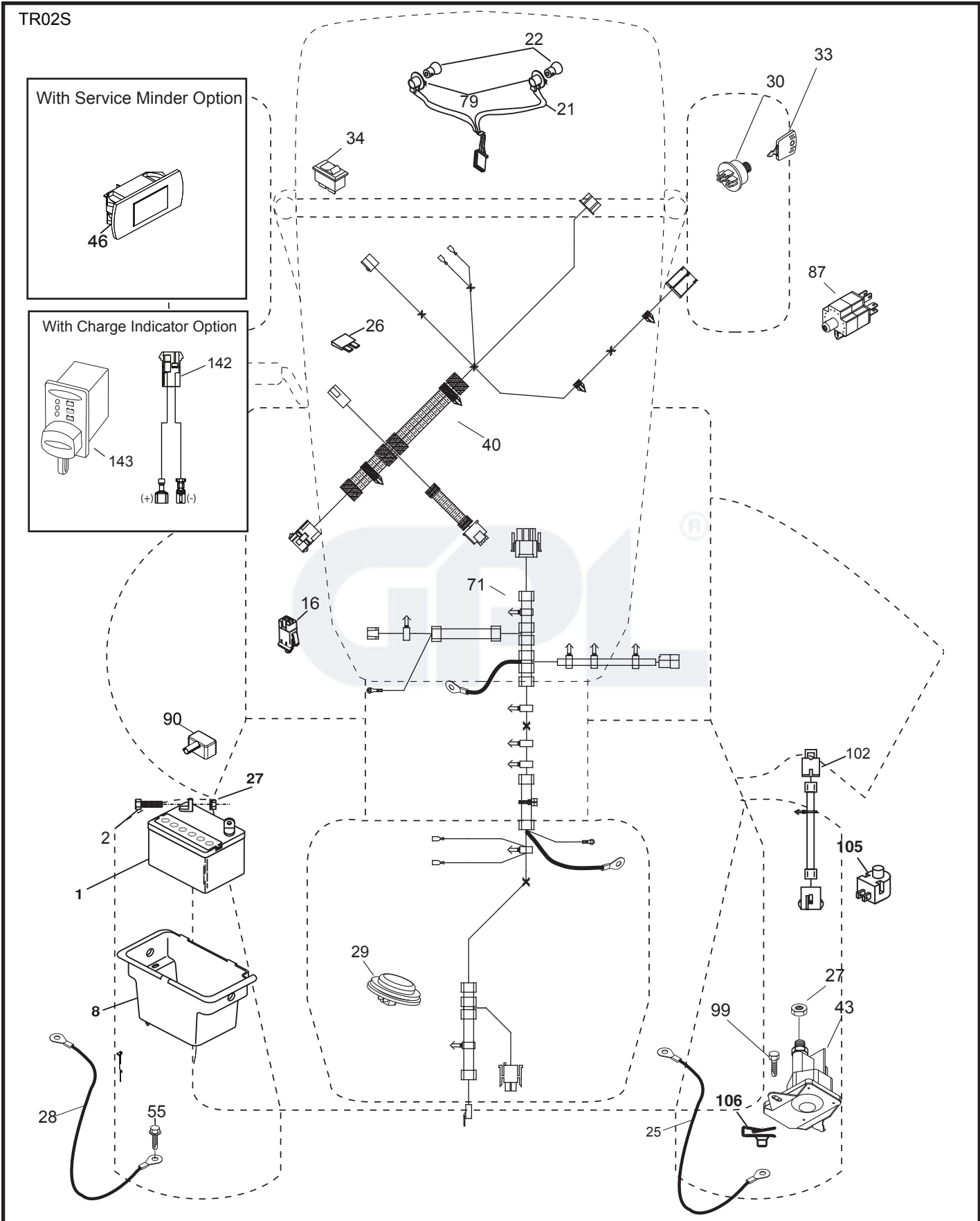

**TRACTOR - MODEL NO. YT46 (96043019700), PRODUCT NO. 960 43 01-97
ELECTRICAL**

KEY PART NO.	PART NO.	DESCRIPTION
1	532 16 34-65	Battery
2	874 76 04-12	Bolt Hex Hd. 1/4-20 unc x 3/4
8	532 19 32-28	Box Battery
16	532 17 61-38	Switch Interlock Push-In
21	532 40 02-52	Harness Socket Light w/4152J
22	532 00 41-52	Bulb Light
25	585 55 55-01	Cable Starter
26	532 17 51-58	Fuse
27	873 51 04-00	Nut Keps Hex 1/4-20 unc
28	532 42 16-86	Cable, Ground
29	532 40 15-45	Switch, Seat
30	532 19 33-50	Switch, Ign.
33	532 41 19-33	Key/Chain
34	532 11 07-12	Switch Light/Reset
40	581 02 31-01	Harness Ign. Dash
43	532 19 25-07	Solenoid
46	586 16 18-01	Gauge Service Reminder
55	817 06 05-12	Screw Thdrol. 5/16-18 x 3/4 TYTT
71	581 02 30-01	Harness Ign. Chassis
79	532 17 52-42	Bulbholder Asm. Incandescent
87	532 19 78-02	Switch Interlock Clutch
90	532 43 53-95	Cover Terminal Battery
99	817 67 04-12	Screw
102	532 40 44-54	Harness Pigtail
105	532 40 75-68	Switch Reverse
106	532 17 48-14	Pal Nut

NOTE: All component dimensions given in U.S. inches
1 inch = 25.4 mm

**TRACTOR - MODEL NO. YT46 (96043019700), PRODUCT NO. 960 43 01-97
CHASSIS**

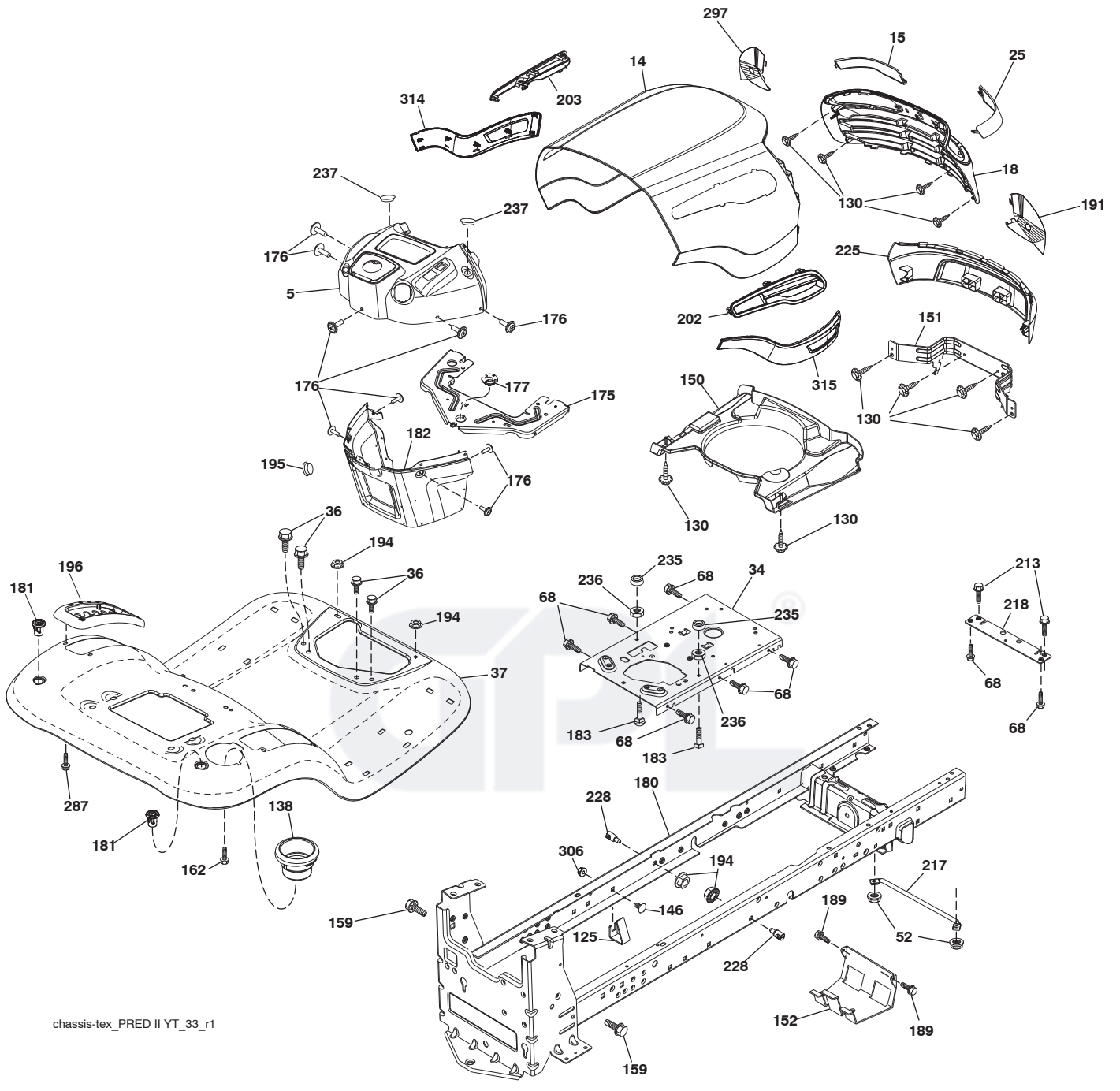

chassis-tex_PRED II YT_33_r1

**TRACTOR - MODEL NO. YT46 (96043019700), PRODUCT NO. 960 43 01-97
CHASSIS**

KEY NO.	PART NO.	DESCRIPTION	KEY NO.	PART NO.	DESCRIPTION
5	532 44 18-82	Dash	183	874 52 05-20	Bolt 5/16-18 x 1-1/4
14	587 89 98-01	Hood	189	817 00 05-12	Screw 5/16-18 x 3/4
15	587 89 86-01	Lens LH	191	532 42 54-07	Insert Reflective RH
18	587 78 54-01	Grille	194	873 90 05-00	Nut Lock Hex Flange 5/16-18
25	587 89 84-01	Lens RH	195	532 40 41-37	Plug Hole Dash Lower
34	580 91 08-01	Plate Engine	196	532 41 45-79	Console Asm. Deck Lift
36	817 06 05-12	Screw 5/16-18 x 3/4	202	587 78 52-01	Vent Side Hood RH
37	532 44 34-76	Fender	203	587 78 51-01	Vent Side Hood LH
52	873 68 05-00	Nut Lock 5/16-18	213	874 76 05-12	Bolt 5/16-18 x 3/4
68	817 49 05-08	Screw Thdrol 5/16-18 x 1/2	217	532 40 91-67	Rod Pivot
125	581 68 48-01	Clip Fuel Line	218	532 19 63-95	X-Piece Hood Stop
130	532 41 63-58	Screw #10 x 0.750	225	587 89 81-01	Bumper
138	532 40 97-30	Cupholder	228	532 19 51-61	Stud Fastner
146	581 85 79-01	Bolt	235	532 40 61-29	Spacer Fender
150	584 86 29-01	Air Duct	236	873 93 05-00	Nut Lock 5/16-18 unc
151	532 44 54-94	Bracket Pivot	237	532 40 37-04	Plug Mount Cargo
152	532 19 95-35	Shield Browning	287	817 60 04-06	Screw 1/4-20 x 3/8
159	817 00 06-12	Screw Hexwsh Thrd 3/8-16 x 3/4	297	532 42 54-06	Insert Reflective LH
162	532 14 24-32	Screw	306	873 90 06-00	Nut Lock
175	532 19 63-04	Crossmember	314	587 77 73-01	Trim Hood Side LH
176	532 40 07-76	Screw 10-24 x 5/8	315	587 77 72-01	Trim Hood Side RH
177	532 19 52-27	Bushing Steering			
180	532 19 54-57	Chassis			
181	532 40 47-96	Bushing Mtg. Fender Crgo			
182	532 40 68-59	Dash Lower			

NOTE: All component dimensions given in U.S. inches
1 inch = 25.4 mm

TRACTOR - MODEL NO. YT46 (96043019700), PRODUCT NO. 960 43 01-97
DRIVE

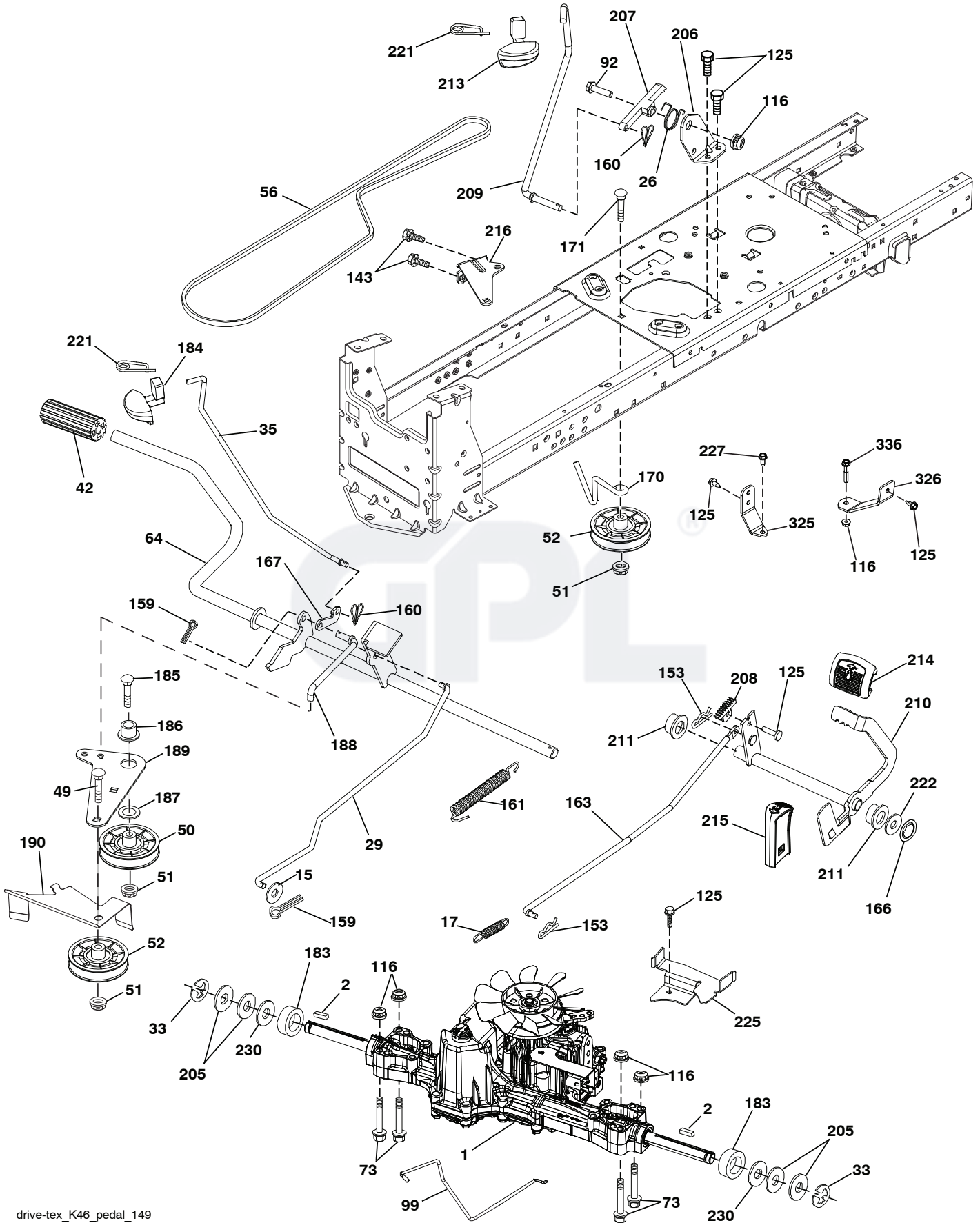

**TRACTOR - MODEL NO. YT46 (96043019700), PRODUCT NO. 960 43 01-97
DRIVE**

KEY NO.	PART NO.	DESCRIPTION	KEY NO.	PART NO.	DESCRIPTION
1	---	Transaxle, Tufftorq K46BT (426120) (Order parts from transaxle manufacturer)	183	532 13 70-57	Spacer Axle
2	532 12 35-83	Key Square	184	587 65 37-01	Handle Parking Brake
15	819 13 13-16	Washer 13/32 x 13/16 x 16 Ga.	185	872 11 06-22	Bolt
17	532 41 36-78	Spring, Brake	186	532 19 43-21	Spacer Retainer
26	532 19 96-79	Spring Return Cruise	187	819 13 32-10	Washer
29	532 40 38-06	Rod, Brake	188	532 19 43-23	Link Clutch Ground Drive
33	812 00 00-01	Ring E	189	532 19 43-17	Bellcrank Ground Drive
35	583 86 45-01	Rod, Brake, Park	190	532 19 43-18	Keeper Bellcrank Ground Drive
42	532 12 48-72	Cover, Foot Pedal	205	532 12 17-48	Washer 25/32 x 1-5/8 x 16 Ga.
49	872 11 06-14	Bolt	206	532 44 85-96	Bracket Mount Latch Cruise
50	532 19 43-27	Pulley Idler Flat	207	532 19 78-68	Latch Control Cruise
51	873 90 06-00	Lock Nut 3/8-16	208	532 19 78-69	Gear Sector Control Cruise
52	532 19 43-26	Idler V-Groove	209	532 19 95-92	Rod Control Cruise
56	532 13 09-69	V-Belt, Drive	210	532 40 09-80	Rocker Asm. Pedal Control
64	532 19 78-65	Shaft Asm. Pedal Brake Control	211	532 12 01-83	Bearing Nylon
73	874 49 05-40	Bolt Hex 5/16-18 x 2 1/2 G.5	213	532 40 31-19	Knob Control Cruise
92	874 76 05-20	Bolt Fin Hex 5/16-18 unc x 1.25	214	532 42 12-63	Pedal Forward
99	532 41 57-42	Rod Spring Bypass	215	532 40 17-23	Pedal Reverse
116	873 90 05-00	Nut Lock Hex Flange 5/16-18	216	532 19 61-31	Bracket Pulley Idler
125	817 00 05-12	Screw 5/16-18 x 3/4	221	532 40 31-87	Retainer Spring Clip Handle
143	817 49 05-08	Screw 5/16-18 x 1/2	222	879 21 20-10	Washer 21/32 x 1-1/4 10 Ga.
153	532 12 47-88	Retainer Spring 1"	225	532 40 33-19	Keeper Belt Transaxle
159	876 02 04-12	Pin Cotter 1/8 x 3/4	227	817 49 05-12	Screw 5/16-18 x 3/4
160	532 16 94-84	Retainer Clip	230	532 18 89-67	Washer .793 x 1.637 x 060
161	532 10 57-09	Spring, Return, Clutch	325	585 66 85-02	Torque Strap K46 LT LH
163	532 44 82-75	Rod Control	326	585 67 08-02	Bracket TRQ STP 46 20" Tire RH
166	532 42 91-64	Nut Push	336	587 25 96-01	Bolt 5/16 - 18 x 1-3/4 Flanged
167	532 40 52-57	Latch Brake Parking			
170	532 19 43-22	Keeper V-Idler			
171	872 11 06-16	Bolt 3/8-16 unc x 2			

NOTE: All component dimensions given in U.S. inches
1 inch = 25.4 mm

**TRACTOR - MODEL NO. YT46 (96043019700), PRODUCT NO. 960 43 01-97
ENGINE**

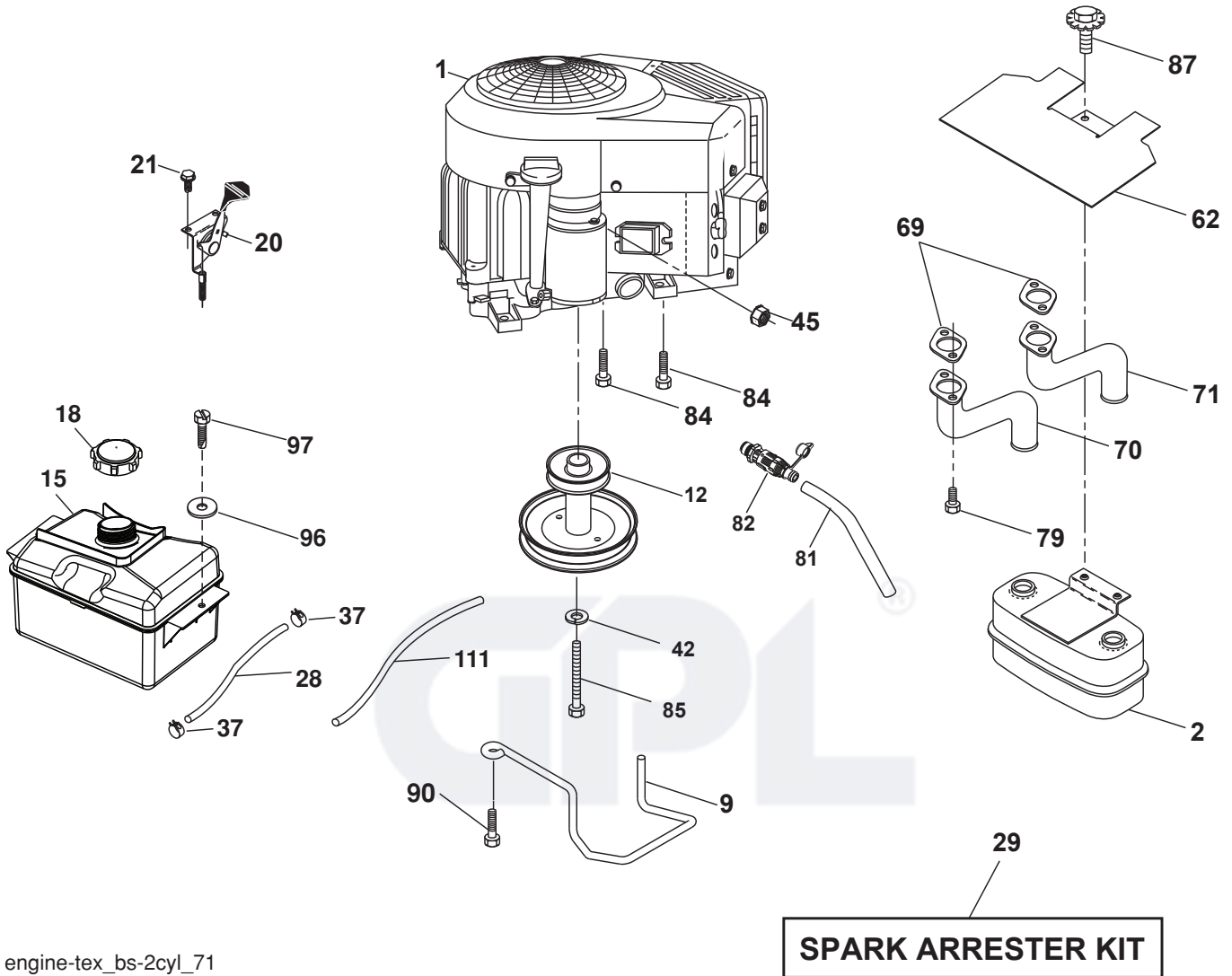

engine-tex_bs-2cyl_71

SPARK ARRESTER KIT

TRACTOR - MODEL NO. YT46 (96043019700), PRODUCT NO. 960 43 01-97 ENGINE

KEY NO.	PART NO.	DESCRIPTION
1	-----	Engine B&S Model No. 44N677-0005-G1 (587639101) (Order parts from engine manufacturer.)
2	532 14 97-23	Muffler
9	584 90 80-01	Keeper Belt Engine
12	532 40 54-72	Pulley Engine
15	532 43 30-07	Tank Fuel
18	581 17 61-01	Cap Fuel
20	532 42 35-02	Control Throttle
21	532 41 63-58	Screw # 10 x 0.750
28	532 40 11-37	Fuel Line
29	532 13 71-80	Spark Arrester Kit
37	532 12 34-87	Clamp Hose
42	810 04 07-00	Washer Lock 7/16
45	873 51 04-00	Nut Keps Hex 1/4-20 unc
62	532 43 40-17	Shield Heat
69	532 16 53-91	Gasket
70	581 88 11-01	Exhaust Tube LH
71	581 88 10-01	Exhaust Tube RH
79	532 18 39-06	Screw Socket Hd. 5/16-18 x 1
81	532 14 84-56	Tube Drain Oil Easy
82	532 42 82-87	Valve Oil Drain
84	817 06 06-20	Screw 3/8-16 x 1-1/4
85	532 17 39-37	Bolt Hex 7/16-20 x 4 x Gr. 5-1.5 Thr
87	537 17 18-77	Bolt 5/16-18 unc x 3/4 w/Sems
90	817 00 06-16	Screw 3/8-16 x 1
96	819 09 14-16	Washer 9/32 x 7/8 x 16 Ga.
97	817 67 04-12	Screw 1/4-20 x 3/4
111	532 41 41-19	Purge Line Carb 3/16

NOTE: All component dimensions given in U.S. inches
1 inch = 25.4 mm

For engine service and replacement parts, call the toll free number for your engine manufacturer listed below:

Briggs & Stratton 1-800-233-3723

Engine Power Rating Information

The gross power rating for individual gas engine models is labeled in accordance with SAE (Society of Automotive Engineers) code J1940 (Small Engine Power & Torque Rating Procedure), and rating performance has been obtained and corrected in accordance with SAE J1995 (Revision 2002-05). Torque values are derived at 3060 RPM; horsepower values are derived at 3600 RPM. Actual gross engine power will be lower and is affected by, among other things, ambient operating conditions and engine-to-engine variability. Given both the wide array of products on which engines are placed and the variety of environmental issues applicable to operating the equipment, the gas engine will not develop the rated gross power when used in a given piece of power equipment (actual "on-site" or net power). This difference is due to a variety of factors including, but not limited to, accessories (air cleaner, exhaust, charging, cooling, carburetor, fuel pump, etc.), application limitations, ambient operating conditions (temperature, humidity, altitude), and engine-to-engine variability. Due to manufacturing and capacity limitations, Briggs & Stratton may substitute an engine of higher rated power for this Series engine.

TRACTOR - MODEL NO. YT46 (96043019700), PRODUCT NO. 960 43 01-97
STEERING ASSEMBLY

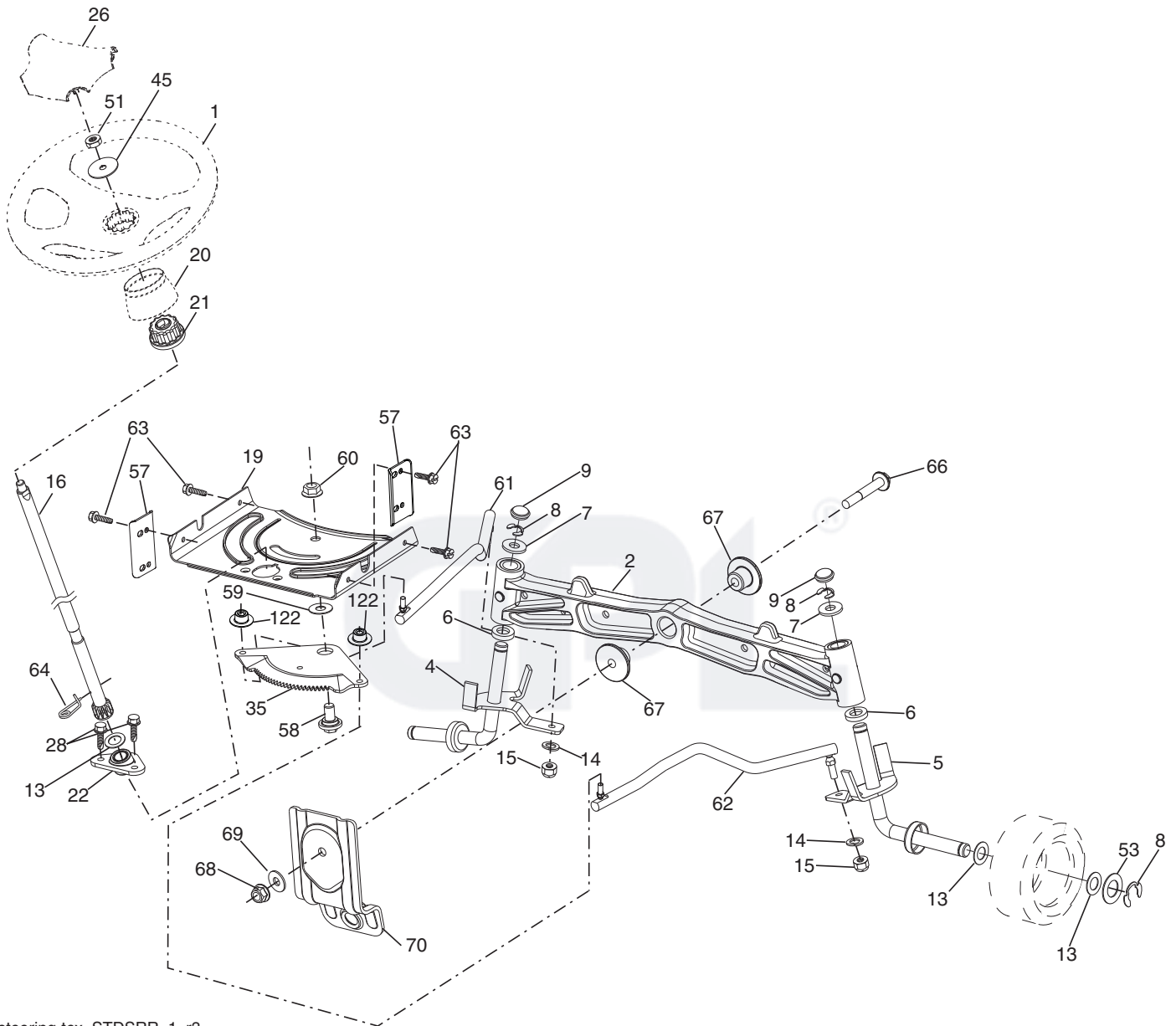

steering-tex_STDSRR_1_r3

**TRACTOR - MODEL NO. YT46 (96043019700), PRODUCT NO. 960 43 01-97
STEERING ASSEMBLY**

KEY NO.	PART NO.	DESCRIPTION
1	532 42 41-46	Wheel, Steering
2	532 19 59-68	Axle Cast Iron
4	532 40 30-87	Spindle Asm., LH
5	532 40 30-88	Spindle Asm., RH
6	532 12 49-31	Washer, Thrust
7	532 12 17-48	Washer 25/32 x 1-5/8 x 16 Ga.
8	812 00 00-29	Ring, Klip #T5304-75
9	532 12 12-32	Cap, Spindle
13	532 12 17-49	Washer 25/32 x 1-1/4 x 16 Ga.
14	810 04 06-00	Washer, Lock Hvy Hlcl Spr 3/8
15	873 54 06-00	Nut, Crown Lock 3/8-24 unf
16	532 40 82-19	Shaft Steering
19	532 19 47-29	Plate Steering
20	532 42 47-40	Boot Steering
21	532 18 67-37	Adapter, Wheel Steering
22	532 42 05-37	Steering Support
26	532 42 41-47	Insert, Wheel Steering
28	817 00 06-12	Screw 3/8-16 x 3/4
35	532 19 47-32	Gear, Sector Plate
45	819 18 38-12	Washer 9/16 ID x 2-3/8 OD 12 Ga.
51	873 94 08-00	Nut Hex Jam Toplock 1/2-20 unf
53	532 18 89-67	Washer Hardened .793 x 1.637 x .060
57	532 40 74-65	Bracket Upstop
58	532 19 47-47	Bolt Shoulder Sector Pivot CFM
59	532 19 47-48	Washer Thrust Sector Steering
60	873 97 10-00	Nut Flange Lock 5/8-11
61	532 19 47-40	Draglink, LH
62	532 19 47-41	Draglink, RH
63	817 00 05-12	Screw 5/16-18 x 3/4
64	532 19 98-49	Retainer Clip Spring Steering
66	871 02 07-48	Bolt Hex Fghd 7/16-14 x 3 Serr
67	532 19 47-37	Bushing PM Front Axle
68	873 90 07-00	Nut Lock Flange 7/16-14 Gr. 5
69	532 19 91-62	Washer 1.5 x .505 x .118
70	585 33 88-01	Bracket Deck Susp. Front
122	532 44 49-62	Cap Gear

NOTE: All component dimensions given in U.S. inches
1 inch = 25.4 mm

**TRACTOR - MODEL NO. YT46 (96043019700), PRODUCT NO. 960 43 01-97
MOWER DECK**

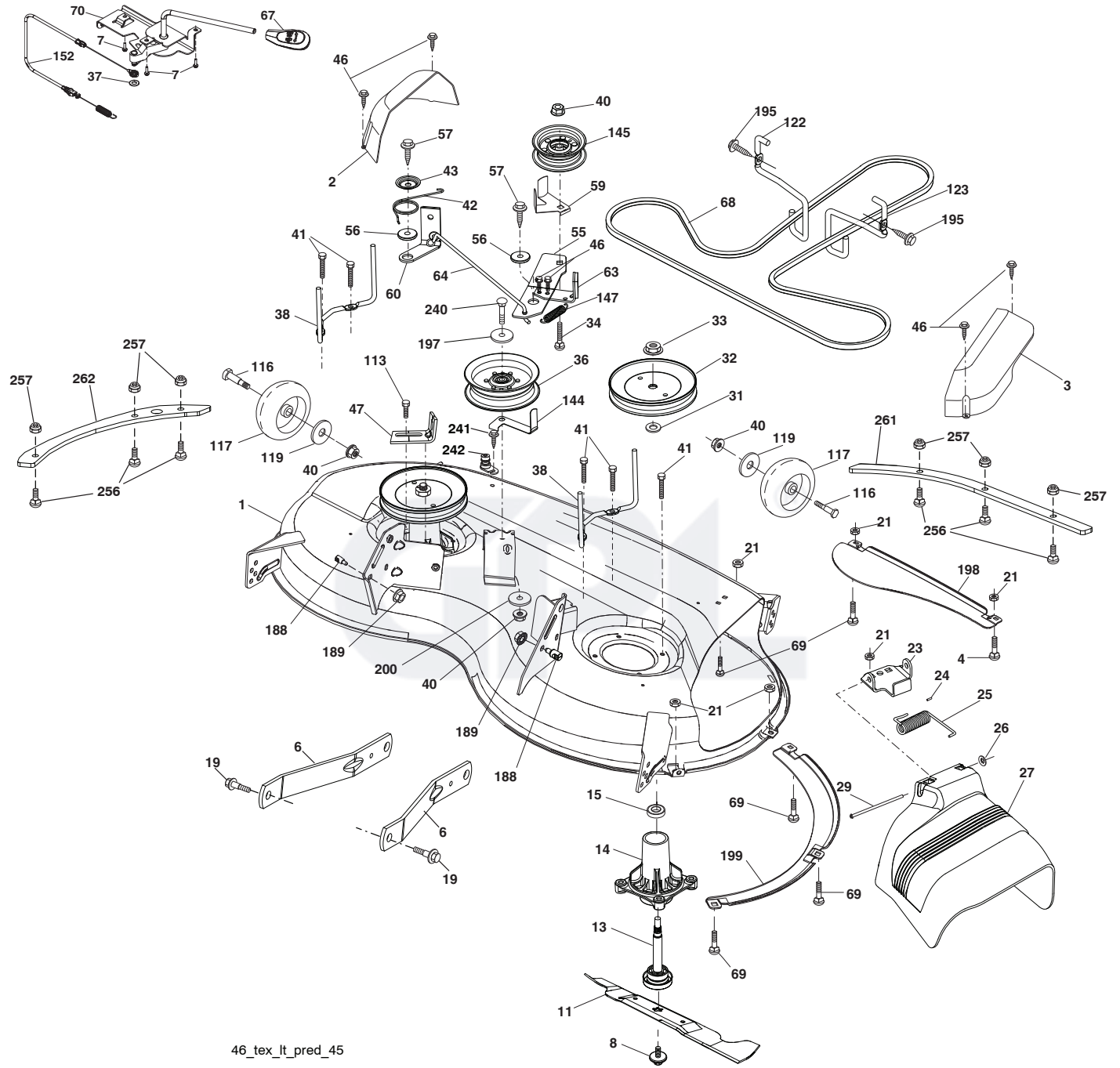

46_tex_lt_pred_45

**TRACTOR - MODEL NO. YT46 (96043019700), PRODUCT NO. 960 43 01-97
MOWER DECK**

KEY NO.	PART NO.	DESCRIPTION	KEY NO.	PART NO.	DESCRIPTION
1	583 90 09-08	Mower Housing	67	532 40 30-12	Handle, Clutch Cable
2	532 40 55-07	Cover Mandrel LH	68	532 40 51-43	V-Belt
3	532 40 55-06	Cover Mandrel RH	69	872 14 05-05	Bolt
4	874 76 05-12	Bolt Hex Hd 5/16-18 unc	70	532 19 99-72	Clutch Asm. Cable
6	532 19 51-86	Arm Suspension	113	817 00 05-10	Screw 5/16-18
7	532 41 63-58	Screw # 10 x 0.750	116	532 19 34-06	Bolt, Shoulder
8	532 19 30-03	Bolt/Washer asm 7/16-20 unf	117	532 17 48-73	Wheel, Gauge
11	532 40 53-80	Blade Mower Hi Lift	119	819 13 20-12	Washer 13/32 x 1-1/4 x 12 Ga.
13	532 19 28-72	Shaft Assembly, Mandrel	122	532 19 72-58	Keeper Belt Eng. LH
14	532 18 72-81	Housing, Mandrel	123	532 19 72-59	Keeper Belt Eng. RH
15	532 11 04-85	Bearing, Ball, Mandrel	144	532 19 92-04	Keeper Belt
19	532 19 65-39	Bolt, Shoulder	145	532 19 31-97	Pulley Idler
21	873 68 05-00	Nut	147	532 40 18-72	Spring Return
23	532 19 25-57	Bracket, Deflector	152	584 24 35-01	Cable Clutch Manual w/Spr.
24	532 10 53-04	Cap, Sleeve	188	532 19 51-61	Stud Fastener
25	532 19 70-26	Spring, Torsion, Deflector	189	873 90 05-00	Nut Lock Hex Flange
26	532 11 04-52	Nut, Push	195	817 00 06-12	Screw 3/8-16 x 3/4
27	532 40 53-57	Shield, Deflector	197	819 13 13-12	Washer 13/32 x 13/16 x 12 Ga.
29	532 13 14-91	Rod, Hinge	198	532 40 31-49	Baffle Center Front
31	532 18 76-90	Washer, Spacer	199	532 40 31-50	Baffle Front RH
32	532 19 74-73	Pulley, Mandrel	200	532 41 35-24	Washer 13/32 x 1 x 1/2 11 Ga.
33	532 40 02-34	Nut, Toplock, Flanged	240	874 52 06-36	Bolt 3/8-16 unc x 2-1/4 Gr. 5
34	872 11 06-12	Bolt Carr Sh. 3/8-16 x 1-1/2 Gr. 5	241	532 15 29-27	Screw
36	532 19 73-79	Pulley, Idler, Flat	242	532 41 55-98	Washout Port
37	819 13 13-16	Washer 13/32 x 13/16 x 16 Ga.	256	587 29 64-04	Screw Buttonhead
38	532 43 25-20	Keeper Belt LH Mandrel	257	873 90 04-00	Nut Hex Flange 1/4-20 unc
40	873 90 06-00	Nut, Lock Flg. 3/8-16 unc	261	585 31 77-05	Plate Reinforcement Front
41	584 95 39-01	Bolt Hex Wshrhd 3/16-18 x 1.19	262	585 31 78-05	Plate Reinforcement Side
42	532 19 84-10	Spring Torsion Brake	--	532 41 64-05	Quick Connect Coupling
43	532 19 72-56	Spring Torsion Retainer	--	532 19 28-70	Mandrel Assembly (Includes housing (Key#14), shaft assembly (Key#13), and bearing only (Key#15) - pulley/nut/washer and blade bolt/washers not included)
46	532 13 77-29	Screw			
47	532 19 72-50	Bracket Clutch Cable			
55	532 19 72-49	Arm, Idler			
56	532 19 90-92	Spacer, Retainer			
57	817 00 06-16	Screw Hexwsh Thd 3/8-16 x 1	--	587 89 34-01	Replacement Mower, Complete
59	532 14 10-43	Guard, Tuv Idler (94)			
60	532 19 94-71	Arm Brake Mower LH			
63	532 19 94-77	Arm Brake Mower			
64	532 40 51-38	Linkage Brake			

NOTE: All component dimensions given in U.S. inches
1 inch = 25.4 mm

**TRACTOR - MODEL NO. YT46 (96043019700), PRODUCT NO. 960 43 01-97
MOWER LIFT**

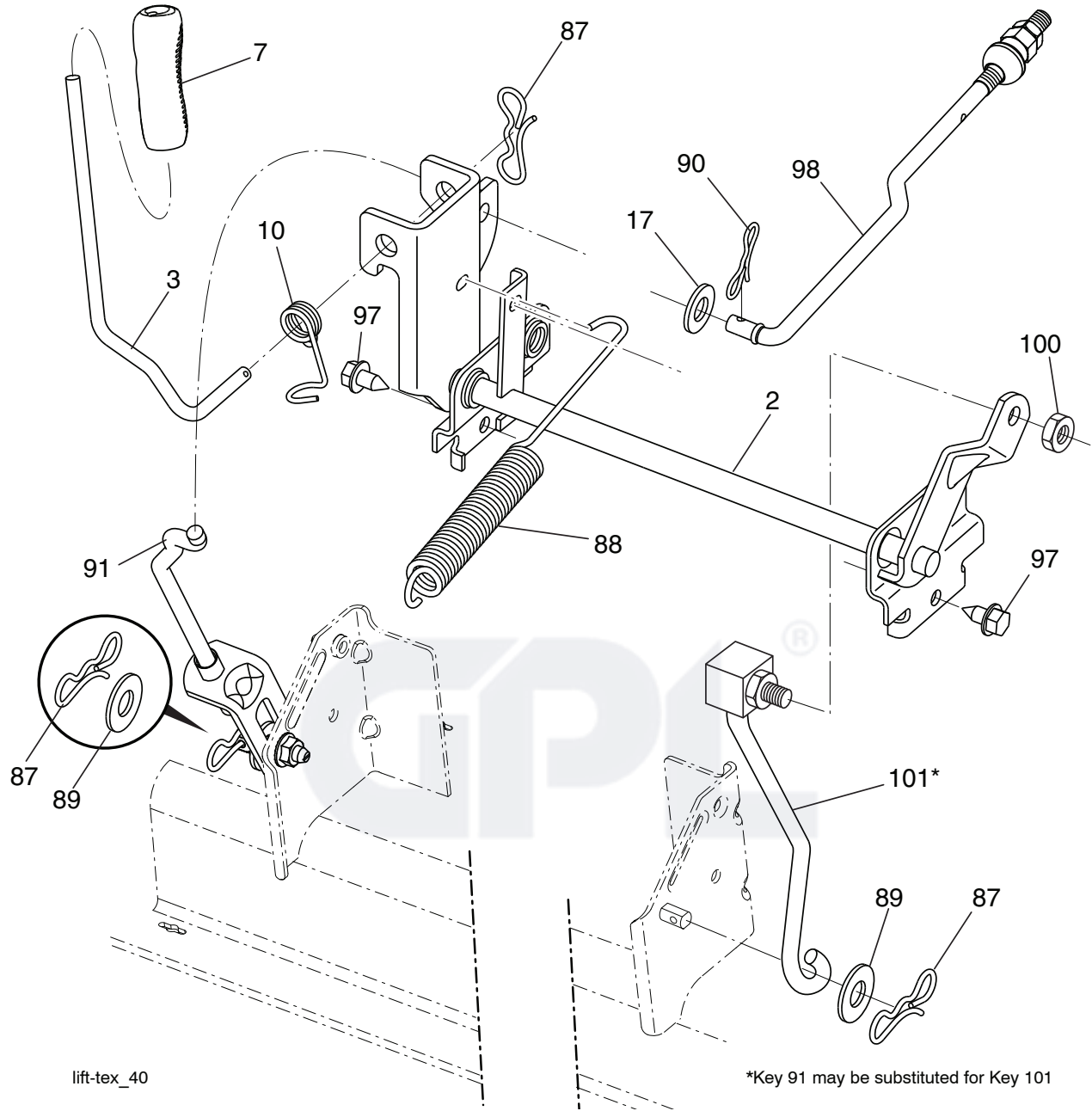

KEY NO.	PART NO.	DESCRIPTION
2	532 42 20-27	Shaft Asm., Lift
3	532 19 52-31	Lever Asm., Lift RH
7	580 96 23-01	Grip, Lever
10	532 19 63-14	Spring Torsion
17	819 13 13-12	Washer 13/32 x 13/16 x 12 Ga.
87	532 19 42-09	Pin Cotter 7/16 Bow Tie Lock
88	532 41 07-10	Spring Lift Assist
89	819 19 19-12	Washer Clear Zinc
90	532 19 42-08	Pin Cotter 5/16 Bow Tie Lock

KEY NO.	PART NO.	DESCRIPTION
91	532 19 51-81	Link Lift Susp Mower Rear
97	817 00 06-12	Screw 3/8-16 x .75 Smgml Tap/R.Z
98	532 19 52-70	Link Lift Susp. Front Mower
100	873 93 06-00	Nut Center Lock 3/8-16 unc
101	532 40 70-03	Link Asm Lift Fixed

NOTE: All component dimensions given in U.S. inches
1 inch = 25.4 mm

**TRACTOR - MODEL NO. YT46 (96043019700), PRODUCT NO. 960 43 01-97
SEAT ASSEMBLY**

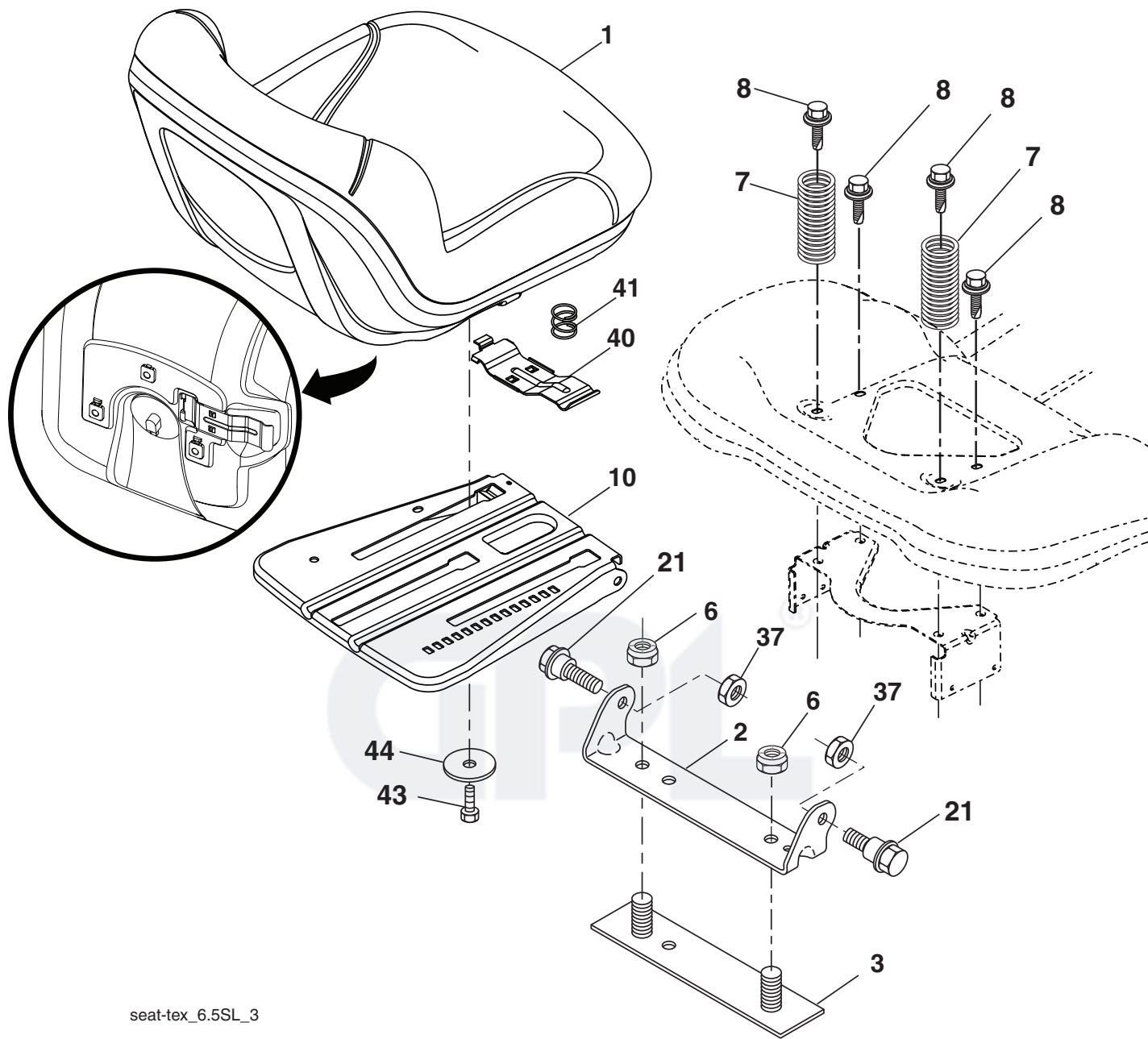

seat-tex_6.5SL_3

KEY NO.	PART NO.	DESCRIPTION
1	532 40 66-25	Seat
2	532 18 01-66	Bracket Pivot Fender
3	532 14 06-75	Strap, Asm Fender
6	873 80 06-00	Nut, Lock w/Ins. 3/8-16 unc
7	532 12 41-81	Spring, Seat Cprsn
8	532 17 18-77	Bolt 5/16-18 unc x 3/4 w/Sems
10	532 19 69-77	Pan, Seat
21	532 17 18-52	Bolt, Shoulder 5/16-18
37	873 80 05-00	Nut, Lock 5/16-18 unc

KEY NO.	PART NO.	DESCRIPTION
40	532 19 76-61	Handle Slide Seat
41	532 19 82-00	Spring Latch Seat
43	874 76 06-12	Bolt Fin Hex 3/8-16 unc x 3/4
44	819 13 38-12	Washer 13/32 x 2-3/8 x 12 Ga.

NOTE: All component dimensions given in U.S. inches
1 inch = 25.4 mm

**TRACTOR - MODEL NO. YT46 (96043019700), PRODUCT NO. 960 43 01-97
DECALS**

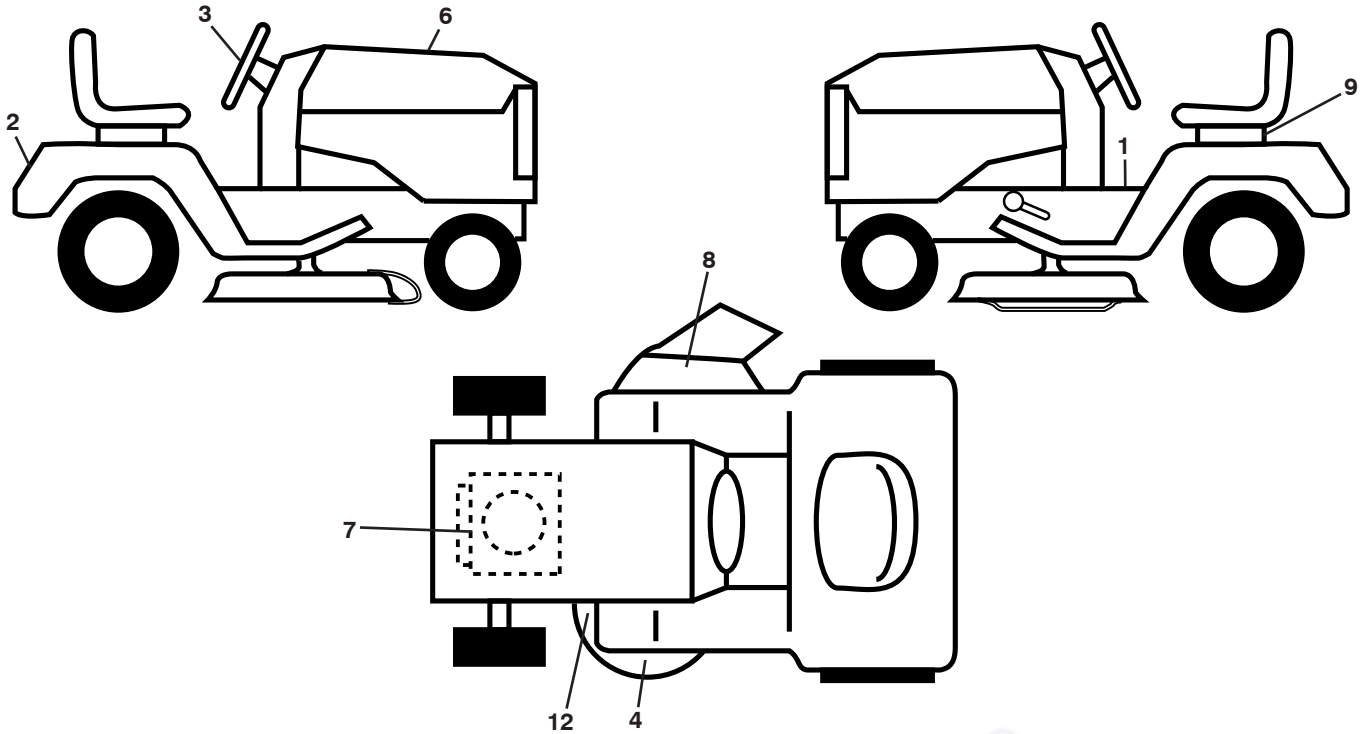

KEY NO.	PART NO.	DESCRIPTION	KEY NO.	PART NO.	DESCRIPTION
1	581 57 89-01	Decal, Fender Warning	9	532 14 50-05	Decal, Battery Dnge/Poi
2	587 67 54-01	Decal, Fender Logo	12	581 58 00-01	Decal, Mower V-Belt Schematic
3	587 73 15-01	Decal, Steering Wheel	--	581 72 48-01	Decal, Bypass
4	587 56 08-01	Decal, Deck	--	532 40 95-05	Pad, Footrest, LH
6	581 62 82-01	Decal, Replacement	--	532 40 95-07	Pad, Foot Pedal Control
7	585 55 69-01	Decal, Engine HP	--	587 69 82-26	Manual, Operator's (Eng./Span.)
8	584 90 46-01	Decal, Deflect. Warning	--	587 69 82-27	Manual, Part's (Eng./Span.)

WHEELS AND TIRES

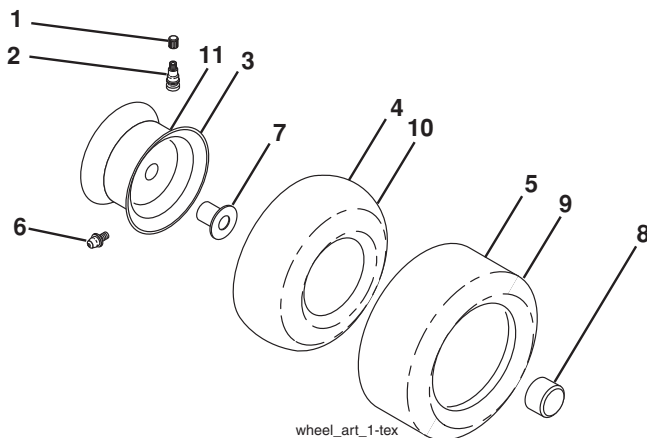

KEY NO.	PART NO.	DESCRIPTION
1	532 05 91-92	Cap Valve Tire
2	532 06 51-39	Stem Valve
3	532 13 83-36	Rim Front
4	532 05 99-04	Tube Front (Service Item Only)
5	532 10 62-22	Tire Front 15 x 6.0-6
6	532 12 49-57	Fitting Grease (Front Wheel Only)
7	532 12 49-59	Bearing Flange (Front Wheel Only)
8	532 17 50-39	Cap Axle Blk 1 50 x 1 00
9	532 13 84-68	Tire R 20 x 8-8 Turf Saver LT
10	532 12 49-26	Tube Rear (Service Item Only)
11	532 13 83-37	Rim Asm 8" Rear
--	532 14 43-34	Sealant, Tire (10 oz. Tube)

NOTE: All component dimensions given in U.S. inches
1 inch = 25.4 mm

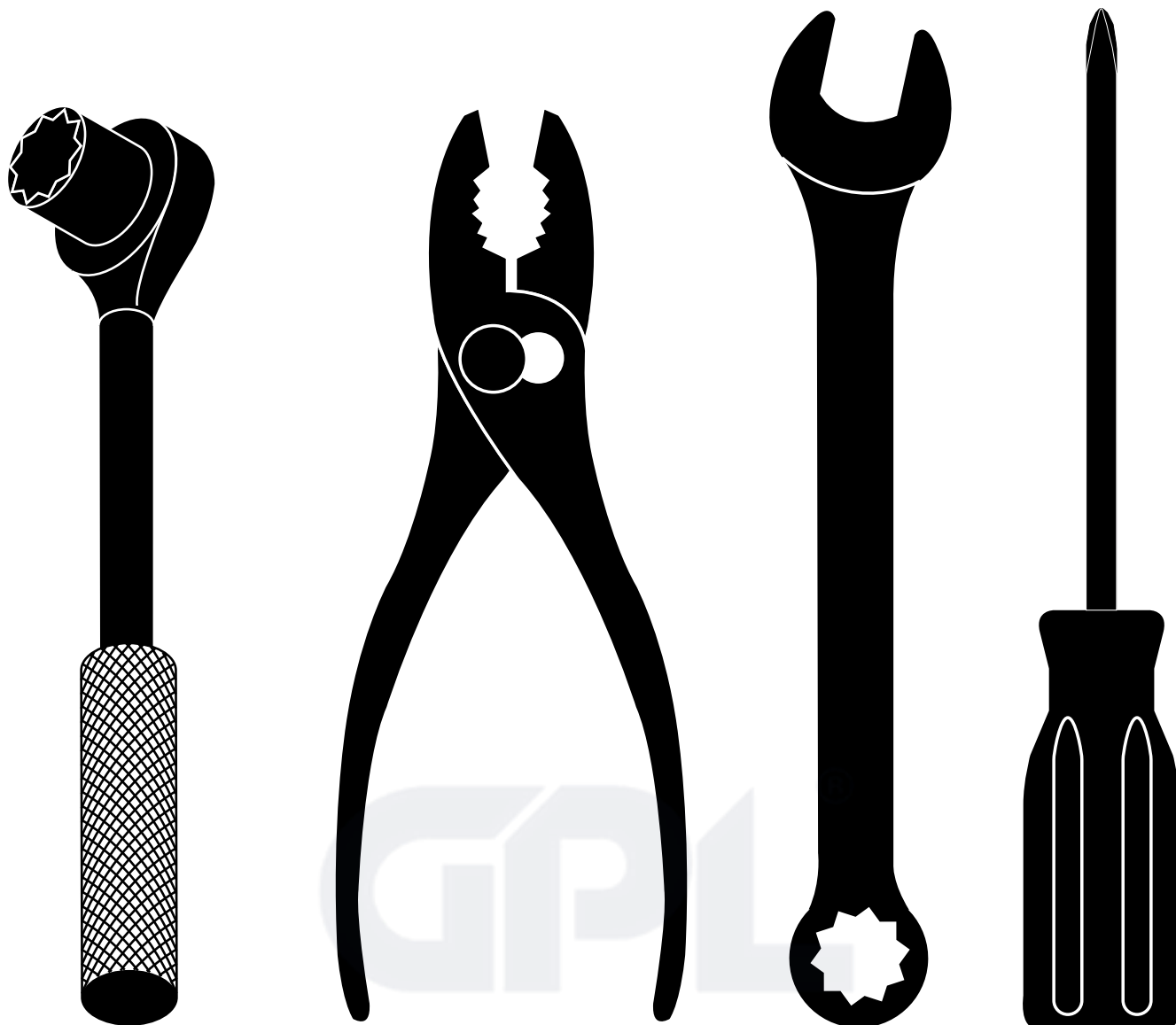

**MANUAL DE REPUESTOS
MODELO NO. YT46 (96043019700)
TRACTOR PARA CÉSPED**

Jonsered®

COMO UTILIZAR ESTE MANUAL

Este manual está diseñado para brindarle al comprador un medio para identificar las piezas del tractor para cuando necesite hacer el pedido de un repuesto. Las ilustraciones pueden o no representar los ensambles reales; por lo tanto, no se recomienda utilizar este manual como una guía para ensamblar o desarmar el tractor. Algunos accesorios y piezas están dibujados en tamaños más grandes para identificarlos con mayor facilidad.

Cada tractor tiene su propio número de modelo.

El número de modelo del tractor se encuentra en el guardabarros debajo del asiento.

Cuando haga el pedido de una pieza, siempre brinde la siguiente información:

- Producto: "TRACTOR"
- NÚMERO DE MODELO: "YT46" (96043019700)"
- Número de pieza
- Descripción de la pieza

ÍNDICE

DIAGRAMA.....	3
DIAGRAMA ELÉCTRICO.....	4-5
CHASIS.....	6-7
TRANSMISIÓN.....	8-9
MOTOR.....	10-11
DIRECCIÓN.....	12-13
PLATAFORMA DE LA CORTADORA DE CÉSPED.....	14-15
ELEVACIÓN DE LA CORTADORA DE CÉSPED.....	16
ASIENTO.....	17
CALCOMANÍAS.....	18

TRACTOR - MODELO NO. YT46 (96043019700), PRODUCTO NO. 960 43 01-97 DIAGRAMA

SCH11-s

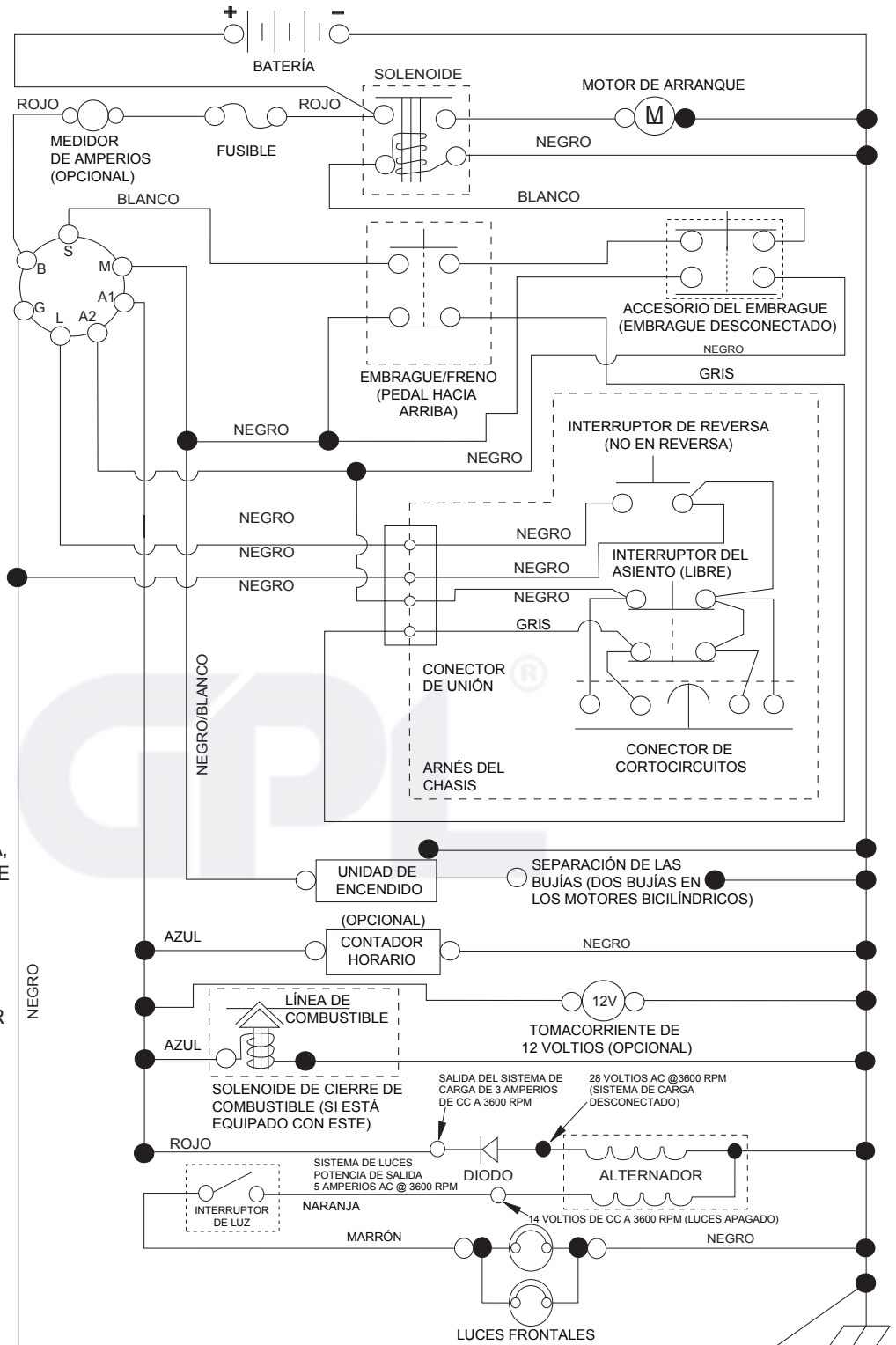

NOTAS:

QUE SU TRACTOR ES EQUIPADO CON UN SISTEMA ESPECIAL DE ALTERNADOR. LAS LUCES NO SON CONECTADAS A LA BATERIA, PERO TIENEN SU PROPIA FUENTE ELECTRICA. A CAUSA DE ESTO, EL BRILLO DE LAS LUCES CAMBIARA CON LA VELOCIDAD DE MOTOR. EN LENTO, LAS LUCES NO SON COMO BRILLANTES. CUANDO EL MOTOR ES ACELERADO, LA LUZ CONSEGUIRÁ MÁS BRILLANTE.

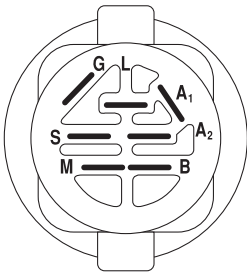

INTERRUPTOR DE ENCENDIDO

POSICIÓN	CIRCUITO «MARCA»
APAGADO	M+G+A1
PONER EN FUNCIONAMIENTO/ANULAR	B+A1
PONER EN FUNCIONAMIENTO	B+A1 L+A2
ARRANCAR	B + S + A1

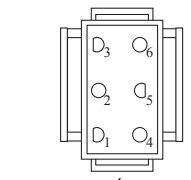

CONEXIÓN DEL ARNÉS DEL CHASIS (LATERAL QUE COINCIDA)

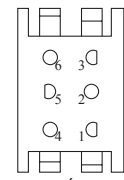

CONEXIÓN PARA EL ARNÉS DEL TABLERO (LATERAL QUE COINCIDA)

NOTA SOBRE LAS ABRAZADERAS DE AISLAMIENTO DEL CABLEADO: SI SE QUITAN LAS ABRAZADERAS DE AISLAMIENTO DEL CABLEADO PARA HACER EL MANTENIMIENTO DE LA UNIDAD, SE LAS DEBERÁ INSTALAR NUEVAMENTE PARA PROTEGER EL CABLEADO ADECUADAMENTE.

● CONEXIONES NO DESMONTABLES

○ CONEXIONES DESMONTABLES

TRACTOR - MODELO NO. YT46 (96043019700), PRODUCTO NO. 960 43 01-97
DIAGRAMA ELÉCTRICO

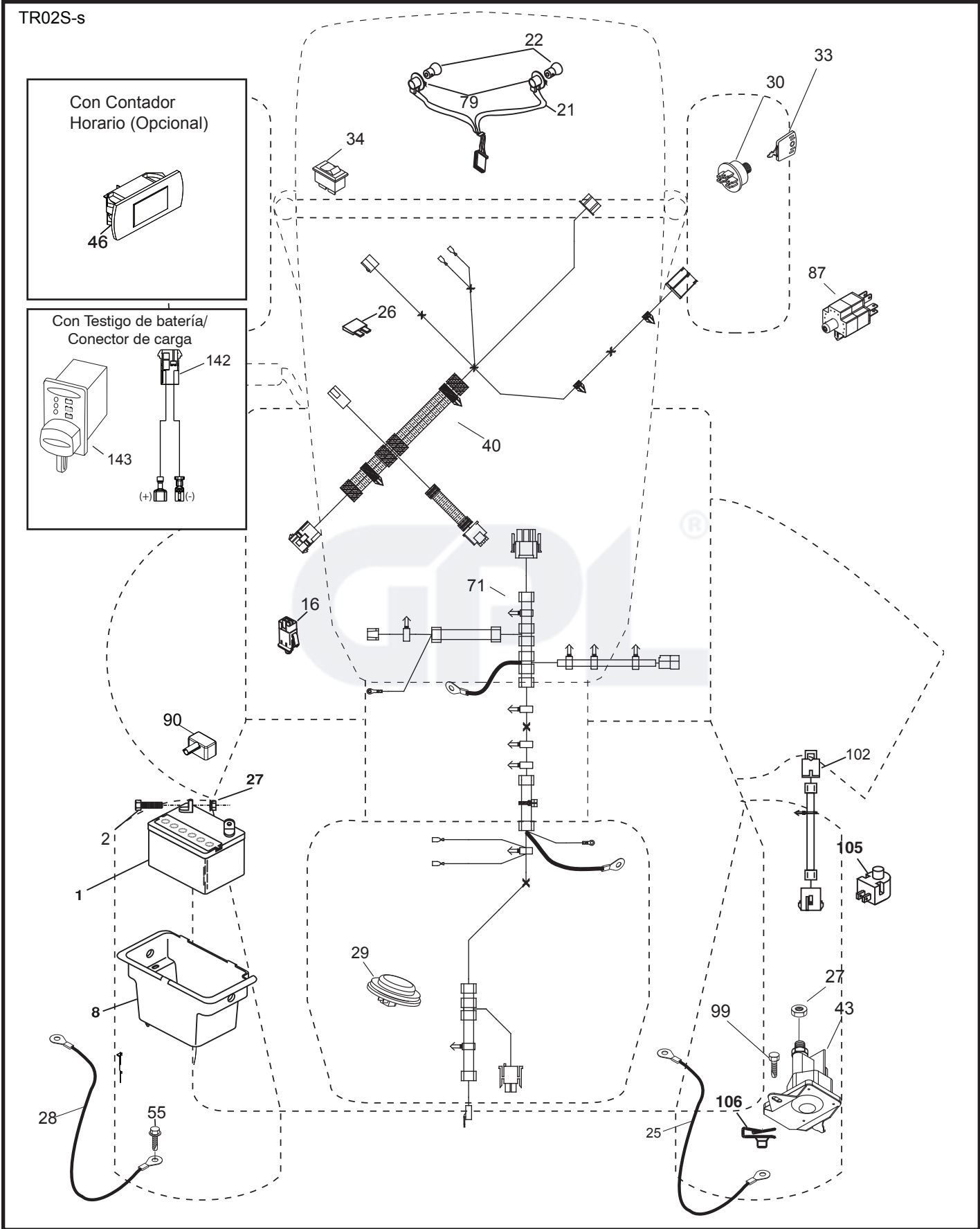

**TRACTOR - MODELO NO. YT46 (96043019700), PRODUCTO NO. 960 43 01-97
DIAGRAMA ELÉCTRICO**

CÓDIGO PIEZA		DESCRIPCIÓN
No.	No.	
1	532 16 34-65	Batería
2	874 76 04-12	Perno de cabeza hexagonal de 1/4-20 unc x 3/4
8	532 19 32-28	Caja de la batería
16	532 17 61-38	Interruptor corta corriente a presión
21	532 40 02-52	Cableado del enchufe para la luz c/4152J
22	532 00 41-52	Bombilla de luz
25	585 55 55-01	Cable
26	532 17 51-58	Fusible
27	873 51 04-00	Tuerca hexagonal 1/4-20 unc
28	532 42 16-86	Cable a tierra
29	532 40 15-45	Interruptor del asiento
30	532 19 33-50	Interruptor de encendido
33	532 41 19-33	Llave/cadena
34	532 11 07-12	Interruptor de luz/de restauración
40	581 02 31-01	Cableado del tablero de encendido
43	532 19 25-07	Solenoides
46	586 16 18-01	Servicio del Indicador
55	817 06 05-12	Tornillo 5/16-18 x 3/4
71	581 02 30-01	Cableado de encendido
79	532 17 52-42	Ensamble del enchufe para la luz
87	532 19 78-02	Interruptor corta corriente del cable de embrague
90	532 43 53-95	Tapa de los bornes de la batería
99	817 67 04-12	Tornillo
102	532 40 44-54	Cableado
105	532 40 75-68	Interruptor
106	532 17 48-14	Tuerca

NOTA: Las dimensiones de todos los componentes están expresadas en pulgadas americanas. 1 pulgada = 25,4 mm

TRACTOR - MODELO NO. YT46 (96043019700), PRODUCTO NO. 960 43 01-97
CHASIS

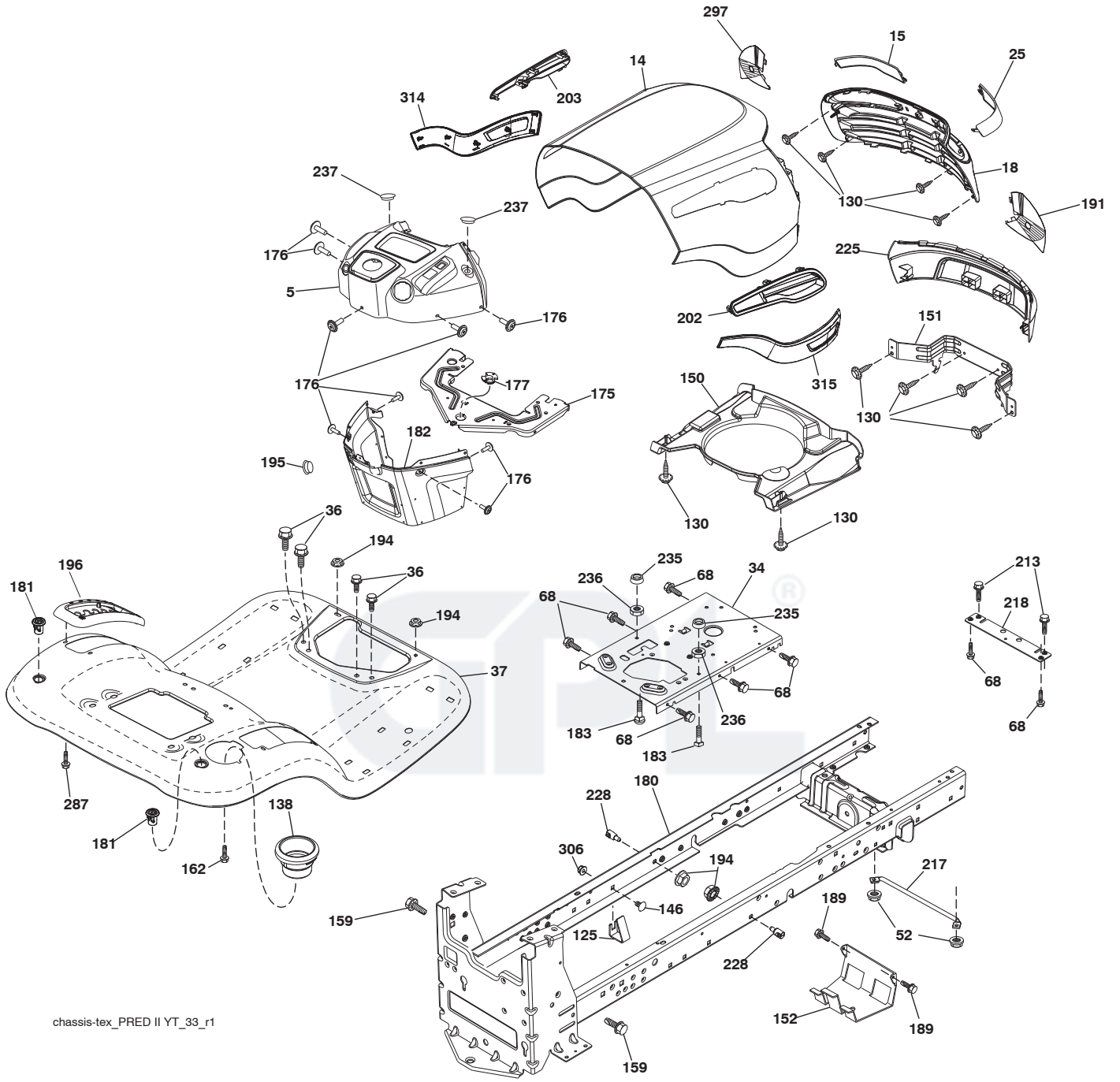

chassis-tex_PRED II YT_33_r1

**TRACTOR - MODELO NO. YT46 (96043019700), PRODUCTO NO. 960 43 01-97
CHASIS**

CÓDIGO PIEZA		DESCRIPCIÓN	CÓDIGO PIEZA		DESCRIPCIÓN
No.	No.		No.	No.	
5	532 44 18-82	Tablero	189	817 00 05-12	Perno 5/16-18 x 3/4
14	587 89 98-01	Capota	191	532 42 54-07	Inserto LD
15	587 89 86-01	Lente izquierdo de la parrilla	194	873 90 05-00	Tuerca de presión de 5/16-18
18	587 78 54-01	Parrilla	195	532 40 41-37	Tapón
25	587 89 84-01	Lente derecho de la parrilla	196	532 41 45-79	Ensamble de la consola de la plataforma de elevación
34	580 91 08-01	Chapa Motor			
36	817 06 05-12	Tornillo de 5/16-18 x 3/4	202	587 78-52-01	Salida de Ventilación (LD)
37	532 44 34-76	Guardabarros	203	587 78 51-01	Salida de Ventilación (LI)
52	873 68 05-00	Tuerca de presión 5/16-18	213	874 76 05-12	Perno
68	817 49 05-08	Tornillo de 5/16-18 x 1/2	217	532 40 91-67	Varilla giratoria
125	581 68 48-01	Soporte	218	532 19 63-95	Tope
130	532 41 63-58	Tornillo No. 10 x 0,75	225	587 89 81-01	Cubierta
138	532 40 97-30	Portavasos	228	532 19 51-61	Sujetador del travesaño
146	581 85 79-01	Perno	235	532 40 61-29	Separador del guardabarros
150	584 86 29-01	Cubierta térmica del conducto	236	873 93 05-00	Tuerca de presión 5/16-18 unc
151	532 44 54-94	Soporte	237	532 40 37-04	Tapón
152	532 19 95-35	Protector contra oscurecimiento	287	817 60 04-06	Tornillo 1/4 - 20 x 3/8
159	817 00 06-12	Tornillo 3/8-16 x 3/4	297	532 42 54-06	Inserto LI
162	532 14 24-32	Tornillo	306	873 90 06-00	Tuerca
175	532 19 63-04	Travesaño	314	587 77 73-01	Borde de Capota (LI)
176	532 40 07-76	Tornillo de 10-24 x 5/8	315	587 77 72-01	Borde de Capota (LD)
177	532 19 52-27	Buje de dirección			
180	532 19 54-57	Chasis			
181	532 40 47-96	Buje de soporte del guardabarros de carga			
182	532 40 68-59	Tablero inferior			
183	874 52 05-20	Perno 5/16-18 x 1-1/4			

NOTA: Las dimensiones de todos los componentes están expresadas en pulgadas americanas. 1 pulgada = 25,4 mm

TRACTOR - MODELO NO. YT46 (96043019700), PRODUCTO NO. 960 43 01-97
TRANSMISIÓN

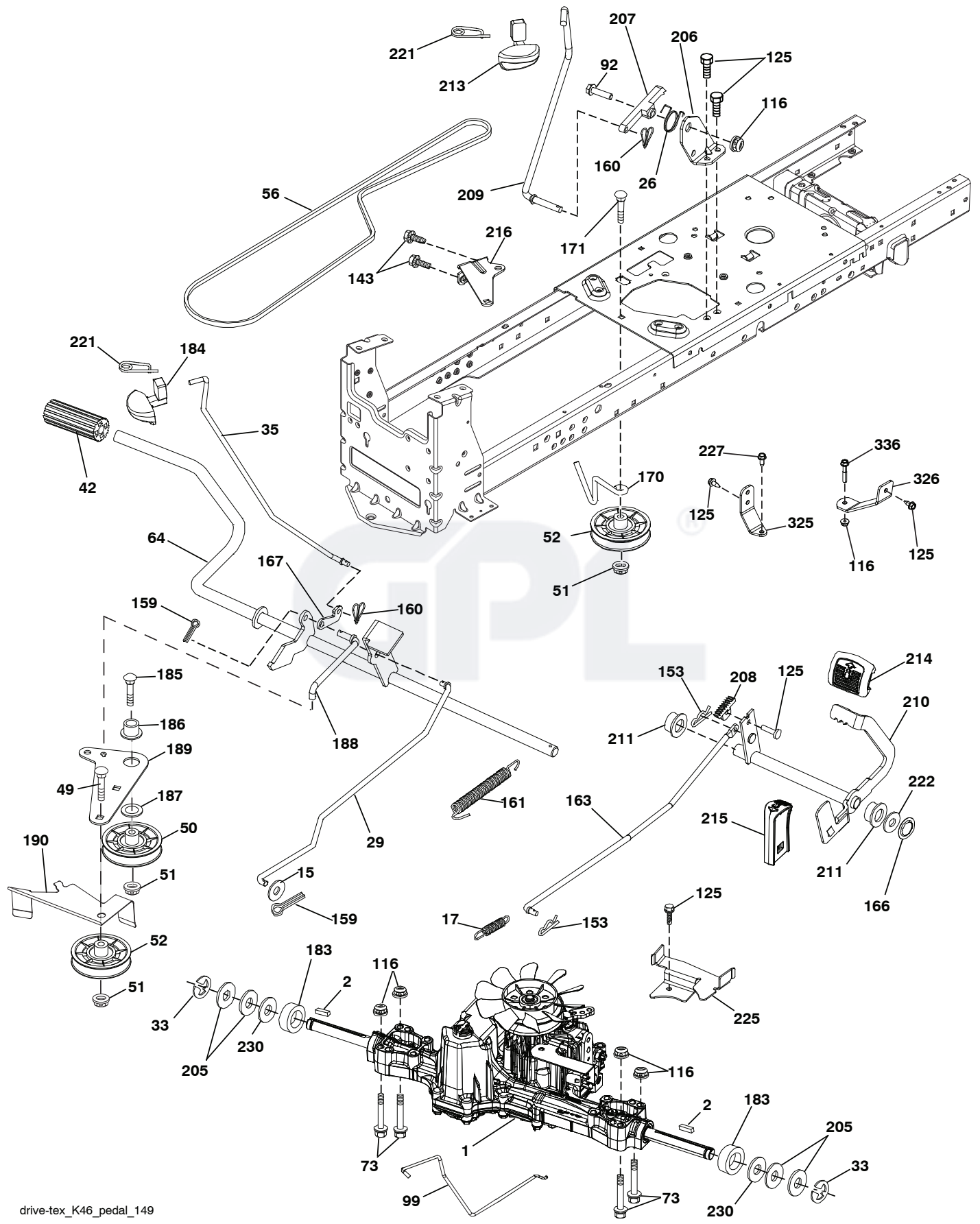

drive-tex_K46_pedal_149

TRACTOR - MODELO NO. YT46 (96043019700), PRODUCTO NO. 960 43 01-97 TRANSMISIÓN

CÓDIGO No.	PIEZA No.	DESCRIPCIÓN	CÓDIGO No.	PIEZA No.	DESCRIPCIÓN
1	---	Transeje, TuffTorq K46BT (426120) (Haga el pedido de las piezas al fabricante del transeje)	185	872 11 06-22	Perno
			186	532 19 43-21	Espaciador de retención
			187	819 13 32-10	Arandela
2	532 12 35-83	Cuña	188	532 19 43-23	Mecanismo de desplazamiento de la varilla de mando del embrague
15	819 13 13-16	Arandelade 13/32x13/16xcalibre 16			
17	532 41 36-78	Resorte de freno	189	532 19 43-17	Palanca acodada del mecanismo de desplazamiento
26	532 19 96-79	Crucero con retorno de muelle			
29	532 40 38-06	Varilla del freno	190	532 19 43-18	Sujetador de la palanca acodada del mecanismo de desplazamiento
33	812 00 00-01	Aro "E"			
35	583 86 45-01	Varilla del freno de mano	205	532 12 17-48	Arandela de 25/32 x 1-5/8 calibre 16
42	532 12 48-72	Cubierta del pedal	206	532 44 85-96	Soporte de montaje del bloqueo del crucero
49	872 11 06-14	Perno			
50	532 19 43-27	Polea loca plana	207	532 19 78-68	Bloqueo del control del crucero
51	873 90 06-00	Tuerca de presión de 3/8-16	208	532 19 78-69	Engranaje del sector de control del crucero
52	532 19 43-26	Polea loca con ranura en "V"			
56	532 13 09-69	Correa trapezoidal de la transmisión	209	532 19 95-92	Varilla de control del crucero
64	532 19 78-65	Ensamble del eje Control del pedal de freno	210	532 40 09-80	Ensamble del control del pedal
			211	532 12 01-83	Rodamiento de nylon
73	874 49 05-40	Perno de 5/16-18 x 2 1/2 G.5	213	532 40 31-19	Perilla de control del crucero
92	874 76 05-20	Perno de cabeza hexagonal con aleta de 5/16-18 unc x 1,25	214	532 42 12-63	Forro del pedal para avanzar
			215	532 40 17-23	Forro del pedal para retroceder
99	532 41 57-42	Varilla del ensamble con resorte de desviación	216	532 19 61-31	Soporte del Polea
			221	532 40 31-87	Abrazadera de retención del resorte de la manija
116	873 90 05-00	Tuerca de presión hexagonal con brida de 5/16-18	222	879 21 20-10	Arandela de 21/32 x 1-1/4 calibre 10
125	817 00 05-12	Tornillo de 5/16-18 x 3/4	225	532 40 33-19	Sujetador de la correa
143	817 49 05-08	Tornillo de 5/16-18 x 1/2	227	817 49 05-12	Tornillo
153	532 12 47-88	Retén del resorte	230	532 18 89-67	Arandela
159	876 02 04-12	Pasador de chaveta de 1/8 x 3/4	325	585 66 85-02	Soporte (LI)
160	532 16 94-84	Abrazadera de retención	326	585 67 08-02	Soporte (LD)
161	532 10 57-09	Resorte de retorno del embrague	336	587 25 96-01	Perno 5/16 - 18 x 1-3/4
163	532 44 82-75	Varilla de control			
166	532 42 91-64	Tuerca de presión			
167	532 40 52-57	Pestillo del freno de mano			
170	532 19 43-22	Sujetador de la correa			
171	872 11 06-16	Perno			
183	532 13 70-57	Separador del eje			
184	587 65 37-01	Manija del freno de mano			

NOTA: Las dimensiones de todos los componentes están expresadas en pulgadas americanas. 1 pulgada = 25,4 mm

**TRACTOR - MODELO NO. YT46 (96043019700), PRODUCTO NO. 960 43 01-97
MOTOR**

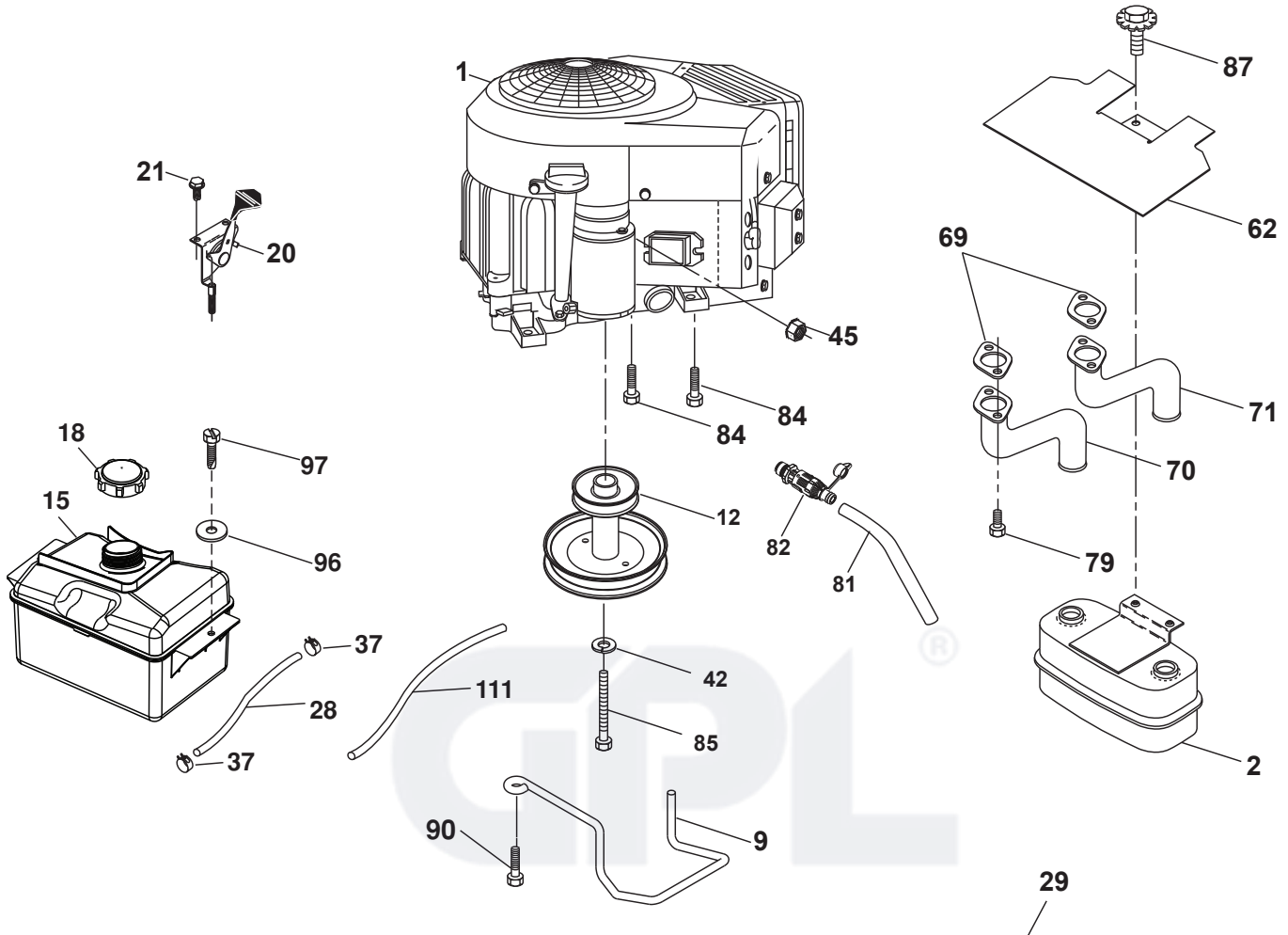

EQUIPO APAGACHISPAS

engine-tex_bs-2cyl_71

TRACTOR - MODELO NO. YT46 (96043019700), PRODUCTO NO. 960 43 01-97 MOTOR

CÓDIGO No.	PIEZA No.	DESCRIPCIÓN
1	-----	Motor B&S modelo No. 44N677-0005-G1 (587639101) (Haga el pedido de las piezas al fabricante del motor.)
2	532 14 97-23	Silenciador
9	584 90 80-01	Ensamble del sujetador de la correa del motor
12	532 40 54-72	Polea del motor
15	532 43 30-07	Tanque de combustible
18	581 17 61-01	Ensamble de la tapa
20	532 17 83-85	Control del regulador
21	532 41 63-58	Tornillo No. 10 x 0,75
28	532 40 11-37	Línea de combustible
29	532 13 71-80	Equipo apagachispas
37	532 12 34-87	Abrazadera de la manguera
42	810 04 07-00	Arandela de presión de 7/16
45	873 51 04-00	Tuerca
62	532 43 40-17	Protector
69	532 16 53-91	Junta
70	581 88 11-01	Silenciador /Tubo LI
71	581 88 10-01	Silenciador /Tubo LD
79	532 18 39-06	Tornillo 5/16-18 x 1
81	532 14 84-56	Tubo de fácil drenaje de aceite
82	532 42 82-87	Conector del drenaje de aceite
84	817 06 06-20	Tornillo 3/8-16 x 1-1/4
85	532 17 39-37	Perno de 7/16-20 x 4
87	537 17 18-77	Perno de 5/16-18
90	817 00 06-16	Tornillo 3/8-16 x 1
96	819 09 14-16	Arandela de 9/32 x 7/8 x calibre 16
97	817 67 04-12	Tornillo 1/4-20 x 3/4
111	532 41 41-19	Línea de purga 3/16

NOTA: Las dimensiones de todos los componentes están expresadas en pulgadas americanas. 1 pulgada = 25,4 mm

Para realizar el mantenimiento del motor y para obtener repuestos, llame al número gratuito del fabricante de su motor que se enumera a continuación:

Briggs & Stratton 1-800-233-3723

Información de Clasificación de Potencia del Motor

La clasificación de potencia para un modelo de motor a gas en particular se designa de acuerdo al código J1940 de SAE (Sociedad de Ingenieros Automotrices) (Procedimiento de Clasificación de Potencia & Torque del Motor Pequeño), y la clasificación de desempeño ha sido obtenida y corregida de acuerdo con el código J1995 de SAE (Revisión 2002-05). Los valores de torque se obtienen a 3060 RPM; los valores de potencia se obtienen a 3600 RPM. La potencia bruta actual del motor será inferior y está afectada, entre otras cosas, por las condiciones ambientales operativas y la variabilidad de motor a motor. Dado ambos un amplio conjunto de productos en los cuales son puestos nuestros motores, y la variedad de emisiones ambientales aplicables al operar el equipo, el motor a gas no desarrollará la potencia nominal cuando sea usado en una parte del equipo acoplado (potencia real "en el-sitio" o potencia neta). Esta diferencia se debe a una variedad de factores que incluyen, pero que no están limitados a, accesorios (filtro de aire, sistema de escape, sistema de carga, sistema de enfriamiento, carburador, bomba de combustible, etc.) limitaciones de la aplicación, condiciones ambientales de operación (temperatura, humedad, altitud), y la variabilidad de motor a motor. Debido a las limitaciones, Briggs & Stratton puede sustituir este motor con clasificación de potencia más alta por esta serie de motor.

TRACTOR - MODELO NO. YT46 (96043019700), PRODUCTO NO. 960 43 01-97
ENSAMBLE DE LA DIRECCIÓN

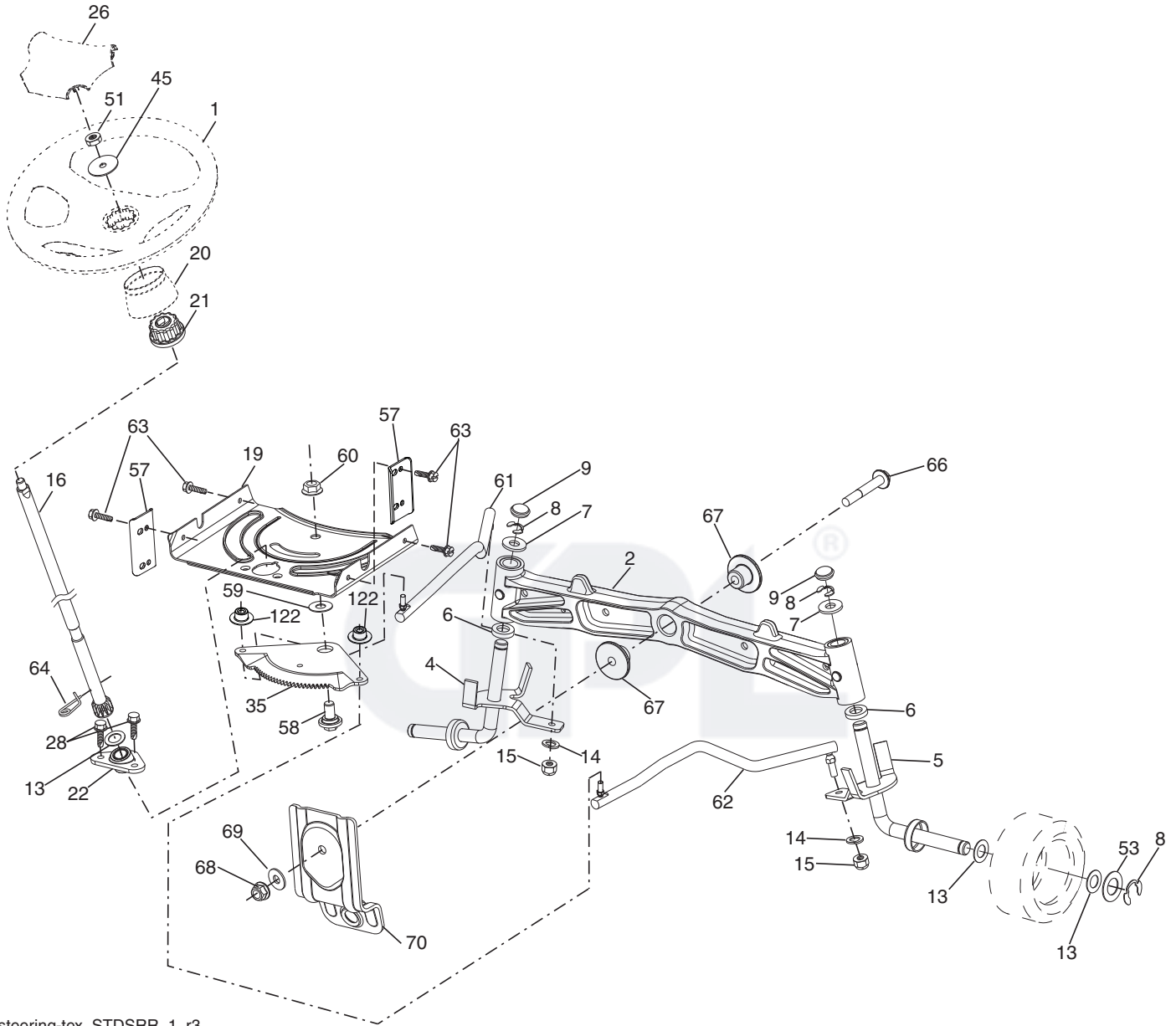

steering-tex_STDSRR_1_r3

**TRACTOR - MODELO NO. YT46 (96043019700), PRODUCTO NO. 960 43 01-97
ENSAMBLE DE LA DIRECCIÓN**

CÓDIGO No.	PIEZA No.	DESCRIPCIÓN
1	532 42 41-46	Volante de dirección
2	532 19 59-68	Eje
4	532 40 30-87	Ensamble del husillo izquierdo
5	532 40 30-88	Ensamble del husillo derecho
6	532 12 49-31	Arandela
7	532 12 17-48	Arandela de 25/32 x 1-5/8 calibre 16
8	812 00 00-29	Abrazadera del aro No. T5304-75
9	532 12 12-32	Tapa del husillo
13	532 12 17-49	Arandela de 25/32 x 1-1/4 calibre 16
14	810 04 06-00	Arandela de presión de 3/8
15	873 54 06-00	Tuerca corona de presión de 3/8-24 unf
16	532 40 82-19	Eje de dirección
19	532 19 47-29	Placa de dirección
20	532 42 47-40	Cubierta de la dirección
21	532 18 67-37	Adaptador del volante de dirección
22	532 42 05-37	Dirección soporte
26	532 42 41-47	Inserto del volante de dirección
28	817 00 06-12	Tornillo de 3/8-16 x 3/4
35	532 19 47-32	Engranaje del sector de la placa
45	819 18 38-12	Arandela de 9/16 ID x 2-3/8 x calibre 12
51	873 94 08-00	Tuerca de presión de 1/2-20 unf
53	532 18 89-67	Arandela reforzada de 793 x 1637 x 0,060
57	532 40 74-65	Tope superior del soporte
58	532 19 47-47	Perno de tope del sector del pivote CFM
59	532 19 47-48	Arandela de empuje del sector de dirección
60	873 97 10-00	Tuerca de presión con brida de 5/8-11
61	532 19 47-40	Barra de acoplamiento izquierda
62	532 19 47-41	Barra de acoplamiento derecha
63	817 00 05-12	Tornillo de 5/16-18 x 3/4
64	532 19 98-49	Abrazadera de retención del resorte de la dirección
66	871 02 07-48	Perno de cabeza 7/16-14 x 3
67	532 19 47-37	Buje PM del eje delantero
68	873 90 07-00	Tuerca de presión con brida de 7/16-14 grado 5
69	532 19 91-62	Arandela de 1,5 x 0,505 x 0,118
70	585 33 88-01	Soporte de la plataforma delantera
122	532 44 49-62	Tapa

NOTA: Las dimensiones de todos los componentes están expresadas en pulgadas americanas. 1 pulgada = 25,4 mm

**TRACTOR - MODELO NO. YT46 (96043019700), PRODUCTO NO. 960 43 01-97
PLATAFORMA DE LA CORTADORA DE CÉSPED**

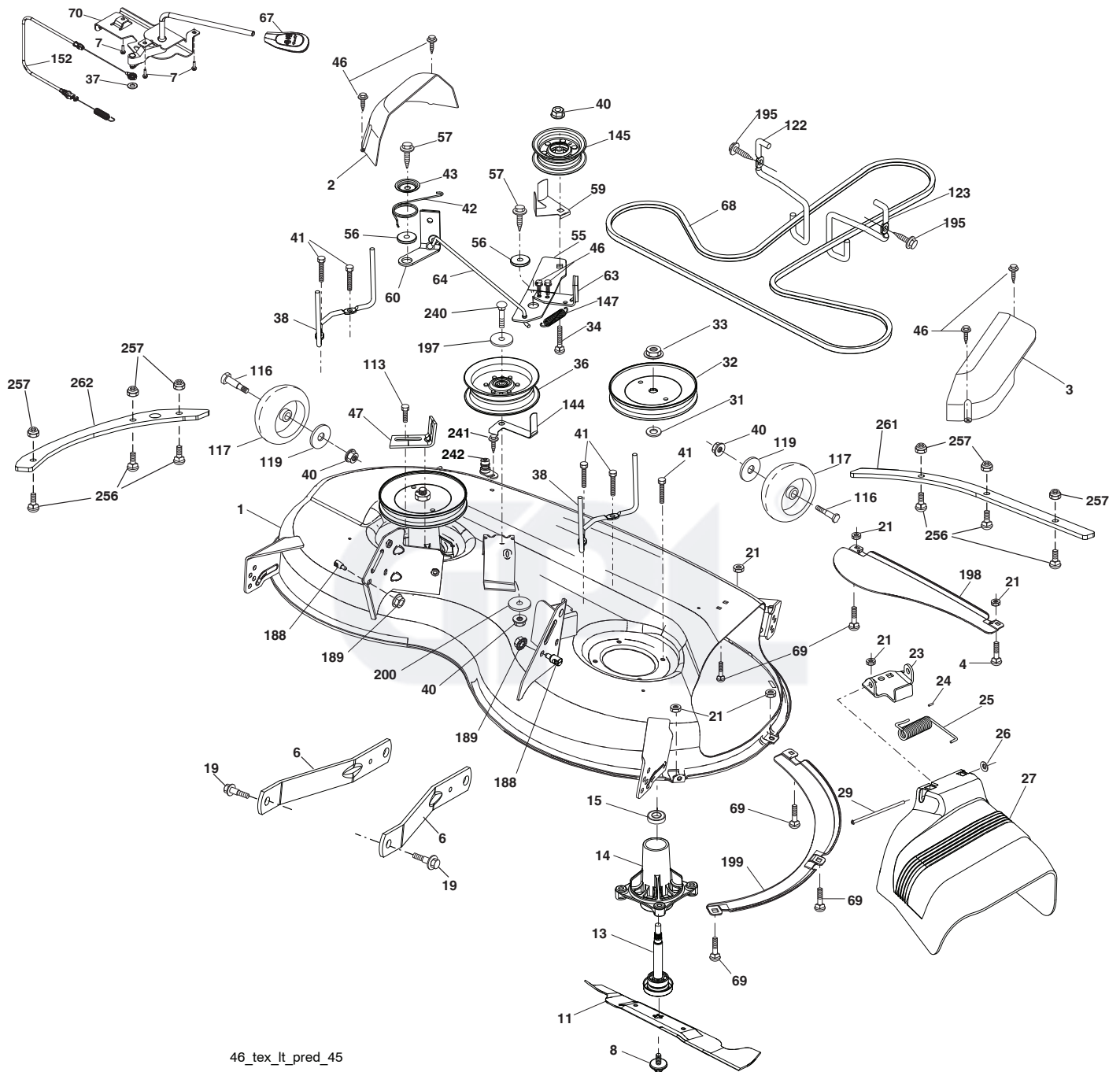

46_text_lt_pred_45

TRACTOR - MODELO NO. YT46 (96043019700), PRODUCTO NO. 960 43 01-97 PLATAFORMA DE LA CORTADORA DE CÉSPED

CÓDIGO No.	PIEZA No.	DESCRIPCIÓN	CÓDIGO No.	PIEZA No.	DESCRIPCIÓN
1	583 90 09-08	Carcasa de la cortadora de césped	67	532 40 30-12	Manija del cable de embrague
2	532 40 55-07	Cubierta izquierda del mandril	68	532 40 51-43	Correa trapezoidal
3	532 40 55-06	Cubierta derecha del mandril	69	872 14 05-05	Perno
4	874 76 05-12	Perno 5/16-18 unc	70	532 19 99-72	Ensamble del embrague Manual
6	532 19 51-86	Brazo de la suspensión	113	817 00 05-10	Tornillo de 5/16-18
7	532 41 63-58	Tornillo No. 10 x 0,750	116	532 19 34-06	Perno de tope
8	532 19 30-03	Perno/arandela del ensamble de 7/16-20 unf	117	532 17 48-73	Calibrador de la rueda
11	532 40 53-80	Cuchilla de la cortadora	119	819 13 20-12	Arandela de 13/32x1-1/4xcalibre 12
13	532 19 28-72	Ensamble del eje del mandril	122	532 19 72-58	Sujetador izquierdo de la correa del motor
14	532 18 72-81	Carcasa del mandril	123	532 19 72-59	Sujetador derecho de la correa del motor
15	532 11 04-85	Rodamiento de bolas del mandril	144	532 19 92-04	Sujetador de la correa
19	532 19 65-39	Perno de tope	145	532 19 31-97	Polea loca
21	873 68 05-00	Tuerca	147	532 40 18-72	Retorno del resorte
23	532 19 25-57	Soporte del deflector	152	584 24 35-01	Cable de embrague manual con resorte
24	532 10 53-04	Tapa de la manga	188	532 19 51-61	Sujetador del travesaño
25	532 19 70-26	Resorte de torsión del deflector	189	873 90 05-00	Tuerca de presión hexagonal con brida
26	532 11 04-52	Tuerca de presión	195	817 00 06-12	Tornillo de 3/8-16 x 3/4
27	532 40 53-57	Protector del deflector	197	819 13 13-12	Arandela de 13/32x13/16xcalibre 12
29	532 13 14-91	Varilla de la bisagra	198	532 40 31-49	Deflector delantero central
31	532 18 76-90	Arandela del separador	199	532 40 31-50	Deflector delantero derecho
32	532 19 74-73	Polea del mandril	200	532 41 35-24	Arandela de 13/32x1x1/2calibre 11
33	532 40 02-34	Tuerca de seguridad con brida	240	874 52 06-36	Perno 3/8-16 unc x 2-1/4
34	872 11 06-12	Perno de 3/8-16 x 1-1/2 grado 5	241	532 15 29-27	Tornillo
36	532 19 73-79	Polea loca	242	532 41 55-98	Puerto de Lavado de la Cubierta
37	819 13 13-16	Arandela de 13/32x13/16xcalibre 16	256	578 29 64-04	Tornillo
38	532 43 25-20	Sujetador de la correa izquierda del mandril	257	873 90 04-00	Tuerca 1/4-20 unc
40	873 90 06-00	Tuerca de presión con brida de 3/8-16 unc	261	585 31 77-05	Placa de refuerzo delantera
41	584 95 39-01	Perno 3/16-18 x 1.19	262	585 31 78-05	Placa de refuerzo lateral
42	532 19 84-10	Resorte de torsión del freno	--	532 41 64-05	Enganche
43	532 19 72-56	Resorte de torsión de retención	--	532 19 28-70	Ensamble del Mandril (solo incluye la carcasa (#14), el ensamble del eje (#13) y el rodamiento (#15); no incluye la polea/tuerca/arandela ni los pernos/arandelas de la cuchilla)
46	532 13 77-29	Tornillo	--	587 89 34-01	Reemplazo de la cortadora de césped, completa
47	532 19 72-50	Soporte del cable de embrague			
55	532 19 72-49	Brazo de la polea			
56	532 19 90-92	Espaciador de retención			
57	817 00 06-16	Tornillo hexagonal con arandela de 3/8-16 x 1			
59	532 14 10-43	Dispositivo de protección de la polea (94)			
60	532 19 94-71	Brazo izquierdo del freno de la cortadora de césped			
63	532 19 94-77	Brazo del freno de la cortadora de césped			
64	532 40 51-38	Varillaje del freno			

NOTA: Las dimensiones de todos los componentes están expresadas en pulgadas americanas. 1 pulgada = 25,4 mm

TRACTOR - MODELO NO. YT46 (96043019700), PRODUCTO NO. 960 43 01-97
ELEVACIÓN DE LA CORTADORA DE CÉSPED

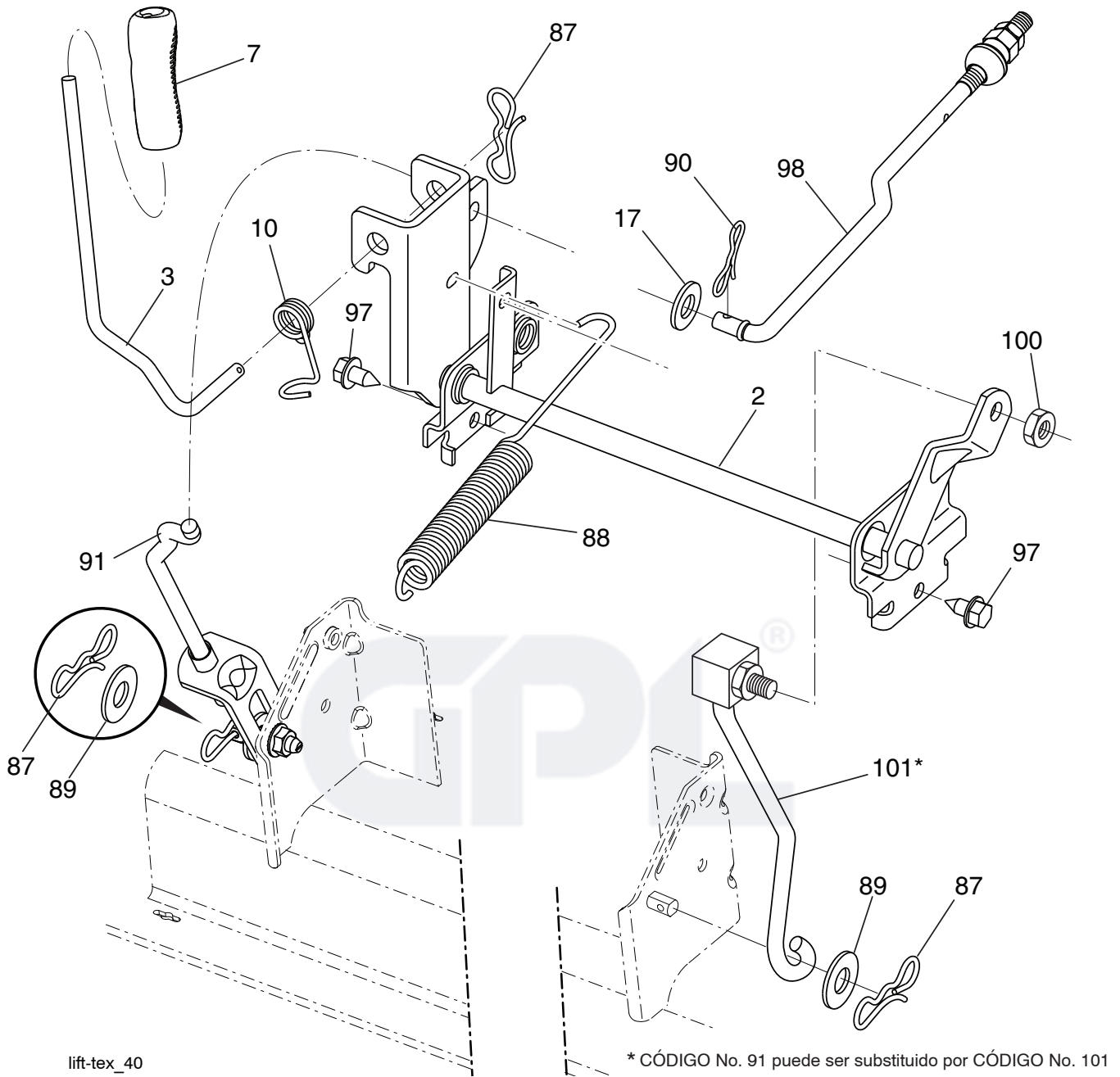

lift-tex_40

CÓDIGO No.	PIEZA No.	DESCRIPCIÓN
2	532 42 20-27	Ensamble del eje de la elevación
3	532 19 52-31	Ensamble de la palanca de elevación derecha
7	580 96 23-01	Mango de la palanca
10	532 19 63-14	Resorte de torsión
17	819 13 13-12	Arandela 13/32 x 13/16 x calibre 12
87	532 19 42-09	Pasador de chaveta de 7/16 con bloqueo en forma de mariposa
88	532 41 07-10	Resorte de ayuda de la elevación
89	819 19 19-12	Arandela de zinc transparente
90	532 19 42-08	Pasador de chaveta de 5/16 con bloqueo en forma de mariposa

CÓDIGO No.	PIEZA No.	DESCRIPCIÓN
91	532 19 51-81	Ensamble del acoplamiento
97	817 00 06-12	Tornillo de 3/8-16 x 0,75
98	532 19 52-70	Acoplamiento frontal de la elevación de la cortadora de césped
100	873 93 06-00	Tuerca de 3/8-16 unc
101	532 40 70-03	Ensamble del acoplamiento elevación

NOTA: Las dimensiones de todos los componentes están expresadas en pulgadas americanas. 1 pulgada = 25,4 mm

**TRACTOR - MODELO NO. YT46 (96043019700), PRODUCTO NO. 960 43 01-97
ENSAMBLE DEL ASIENTO**

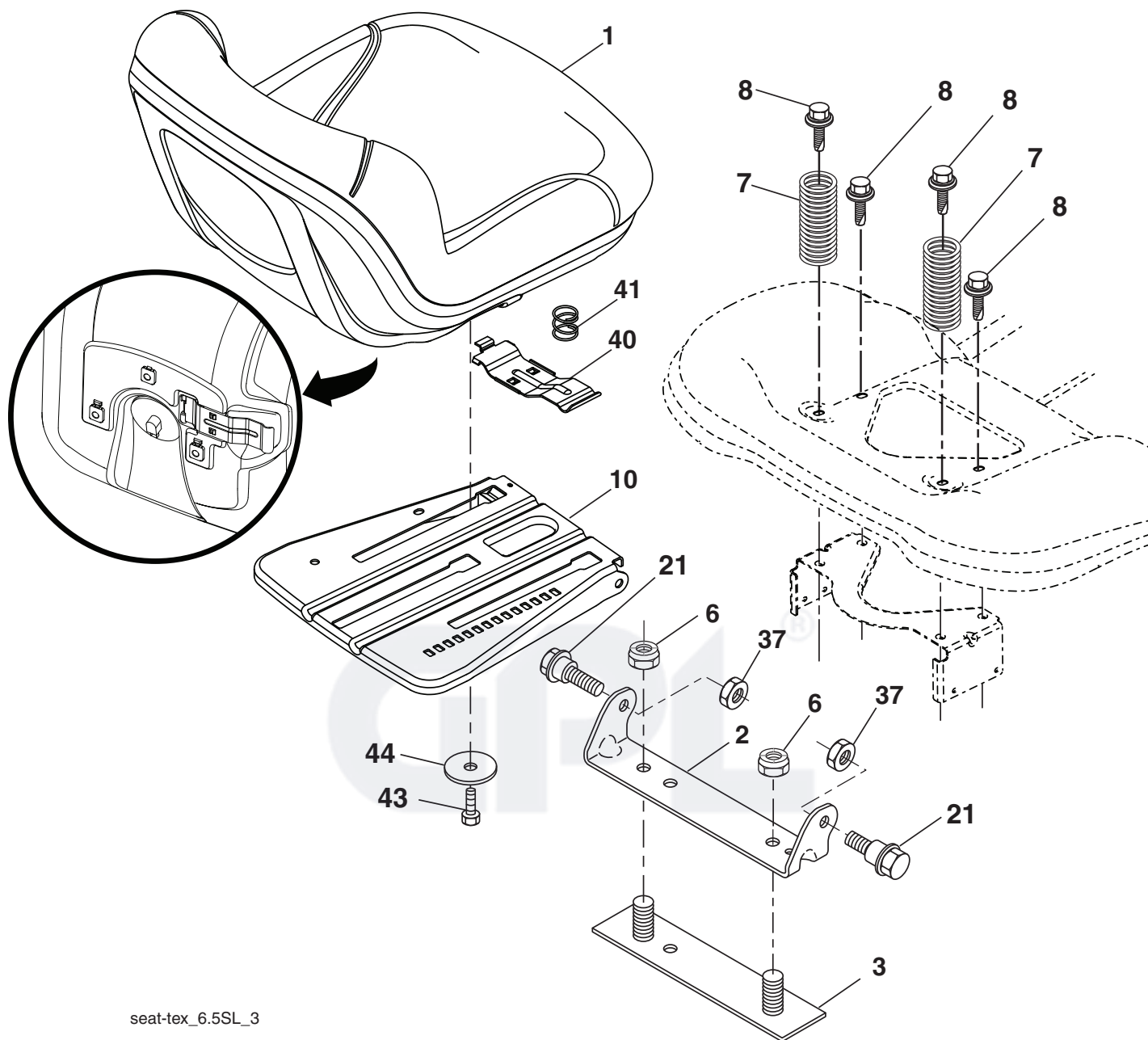

seat-tex_6.5SL_3

CÓDIGO No.	PIEZA No.	DESCRIPCIÓN
1	532 40 66-25	Asiento
2	532 18 01-66	Soporte pivotante del guardabarros
3	532 14 06-75	Conector del ensamble del guardabarros
6	873 80 06-00	Tuerca de presión c/aislamiento de 3/8-16 unc
7	532 12 41-81	Resorte del asiento
8	532 17 18-77	Perno de 5/16" unc x 3/4"
10	532 19 69-77	Bandeja del asiento
21	532 17 18-52	Perno de tope de 5/16-18
37	873 80 05-00	Tuerca de presión de 5/16-18 unc

CÓDIGO No.	PIEZA No.	DESCRIPCIÓN
40	532 19 76-61	Manija para deslizar el asiento
41	532 19 82-00	Resorte para trabar el asiento
43	874 76 06-12	Perno de cabeza hexagonal con aleta de 3/8-16 unc x 3/4
44	819 13 38-12	Arandela de 13/32 x 2-3/8 calibre 12

NOTA: Las dimensiones de todos los componentes están expresadas en pulgadas americanas. 1 pulgada = 25,4 mm

**TRACTOR - MODELO NO. YT46 (96043019700), PRODUCTO NO. 960 43 01-97
CALCOMANÍAS**

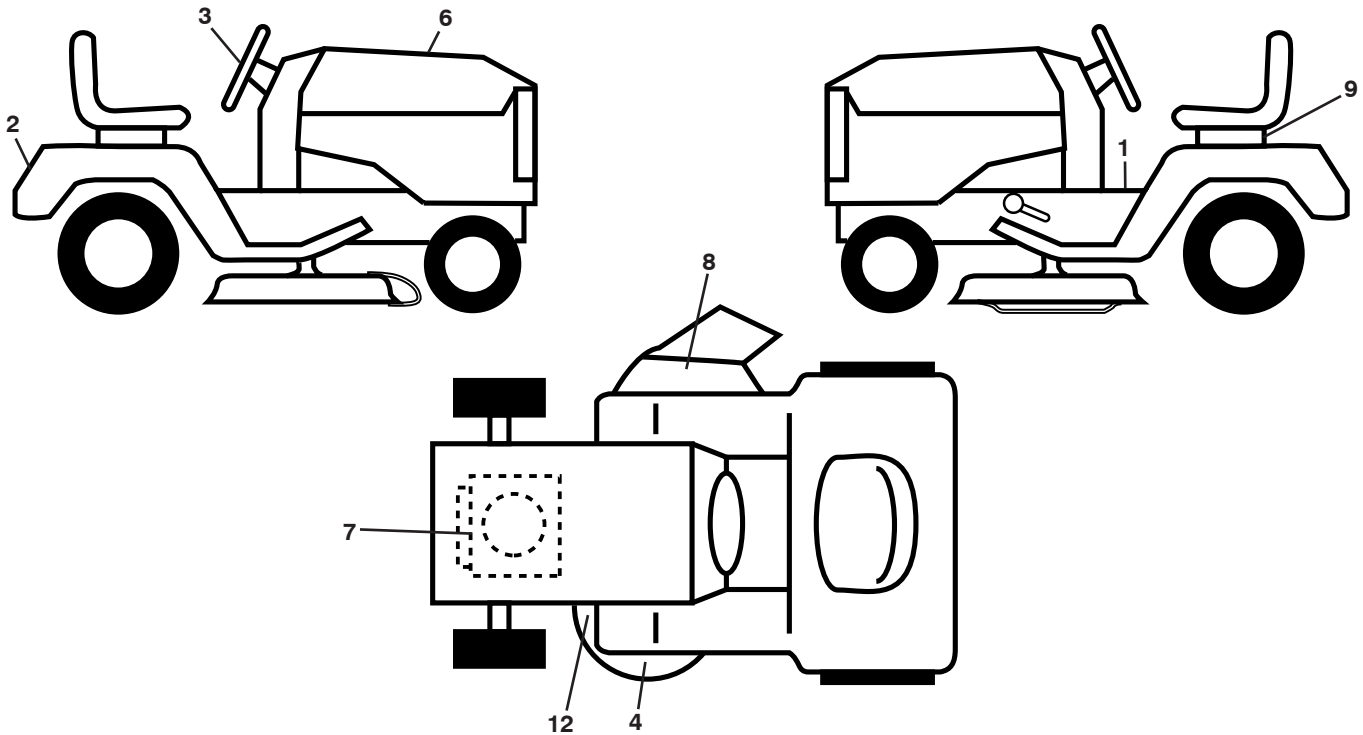

**CÓDIGO PIEZA
No. No.**

CÓDIGO No.	PIEZA No.	DESCRIPCIÓN
1	581 57 89-01	Calcomanía para el guardabarros
2	587 67 54-01	Calcomanía para el guardabarros
3	587 73 15-01	Calcomanía para el volante de dirección
4	587 56 08-01	Calcomanía cubierta
6	581 62 82-01	Calcomanía de reemplazo
7	585 55 69-01	Calcomanía de motor
8	584 90 46-01	Calcomanía
9	532 14 50-05	Calcomanía de Peligro/Punto de interconexión

**CÓDIGO PIEZA
No. No.**

CÓDIGO No.	PIEZA No.	DESCRIPCIÓN
12	581 58 00-01	Calcomanía del diagrama de la cortadora de césped
--	581 72 48-01	Calcomanía para la desviación
--	532 40 95-05	Forro del apoyo para los pies (LI)
--	532 40 95-07	Forro, pedal control del pies
--	587 69 82-26	Manual de Operario (ESPAÑOL/INGLÉS)
--	587 69 52-27	Manual De Repuestos (ESPAÑOL/INGLÉS)

RUEDAS Y NEUMÁTICOS

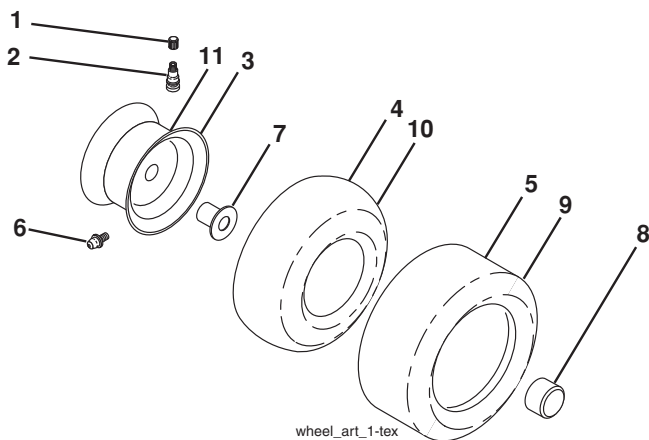

**CÓDIGO PIEZA
No. No.**

CÓDIGO No.	PIEZA No.	DESCRIPCIÓN
1	532 05 91-92	Tapa de la válvula del neumático
2	532 06 51-39	Vástago de la válvula
3	532 13 83-36	Ensamble de las llantas delanteras
4	532 05 99-04	Cámara delantera (Mantenimiento sólo)
5	532 10 62-22	Neumático delantero 15 x 6.0-6
6	532 12 49-57	Accesorio para engrasar (solo para la rueda delantera)
7	532 12 49-59	Rodamiento de la brida (solo para la rueda delantera)
8	532 17 50-39	Tapa del eje 1 50 x 1 00
9	532 13 84-68	Neumático
10	532 12 49-26	Cámara trasera (Mantenimiento sólo)
11	532 13 83-37	Ensamble trasero de la llanta 8"
--	532 14 43-34	Sellador para neumáticos (tubo de 10 onzas [283 gr])

NOTA: Las dimensiones de todos los componentes están expresadas en pulgadas americanas. 1 pulgada = 25,4 mm