

M48, 953534501, 2007-01



---

**SPARE PARTS LIST**

**C** M 48 Pro

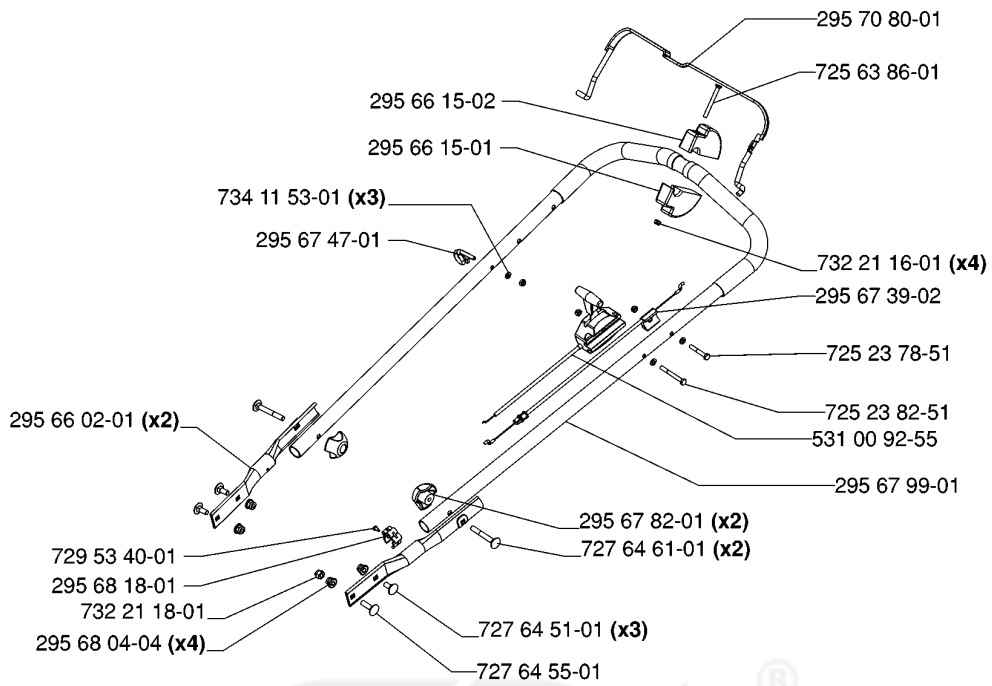

**C** M 48

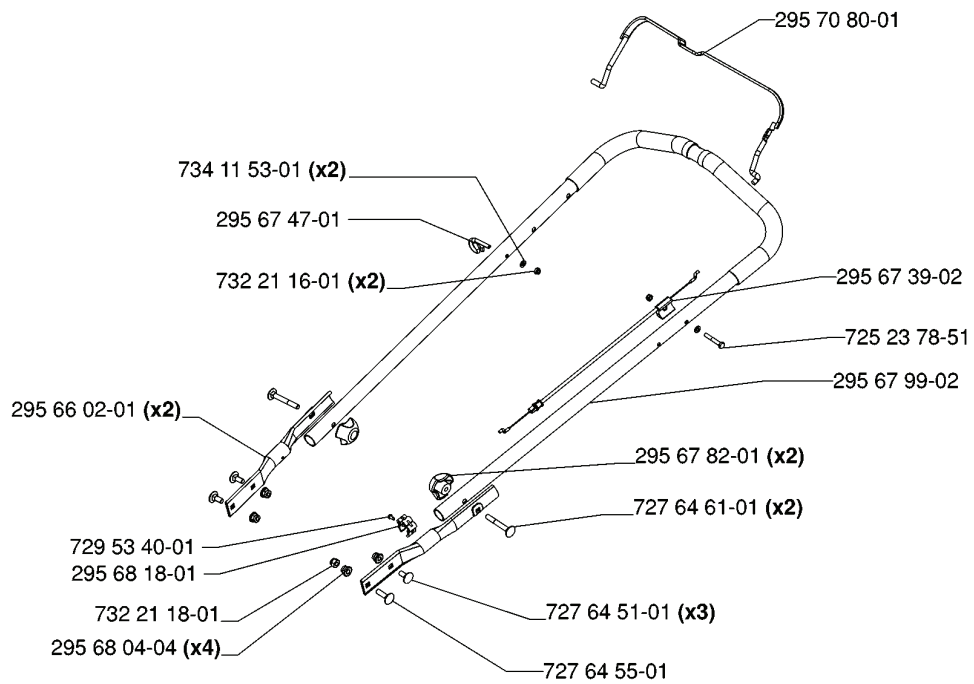

REF.	PART NO.	DESCRIPTION	REMARK	QTY.	KIT
295 66 15-02	295661502	WEIGHT		1	
295 66 15-01	295661501	WEIGHT		1	
734 11 53-01	734115301	WASHER		3	
729 53 40-01	729534001	SCREW CCRPANT		1	
295 68 04-04	295680404	LOCK NUT		4	
727 64 51-01	727645101	SCREW RSQM		3	
727 64 61-01	727646101	SCREW RSQM		2	
295 67 82-01	295678201	HANDLE		2	
295 67 99-01	295679901	HANDLE ASSY		1	
531 00 92-55	531009255	CONTROL		1	
725 23 82-51	725238251	SCREW EHHM		1	
725 23 78-51	725237851	SCREW EHHM		1	
295 67 39-02	295673902	CABLE		1	
725 63 86-01	725638601	SCREW IHCSFM		1	
295 67 47-01	295674701	HOLDER		1	
732 21 16-01	732211601	LOCK NUT		2	
295 66 02-01	295660201	BRACKET		2	
295 68 18-01	295681801	HOLDER		1	
732 21 18-01	732211801	LOCK NUT		1	
727 64 55-01	727645501	SCREW RSQM		1	
295 67 99-02	295679902	HANDLE ASSY		1	

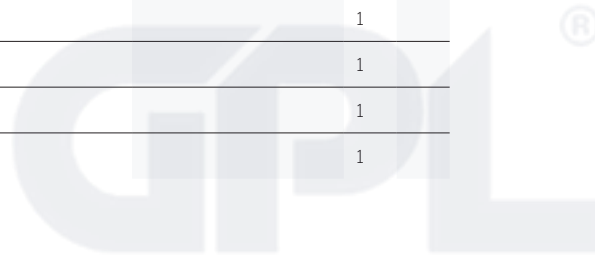

**A M 48 Pro**  
**Motor compl 295 68 13-01 (Honda 160 CV)**

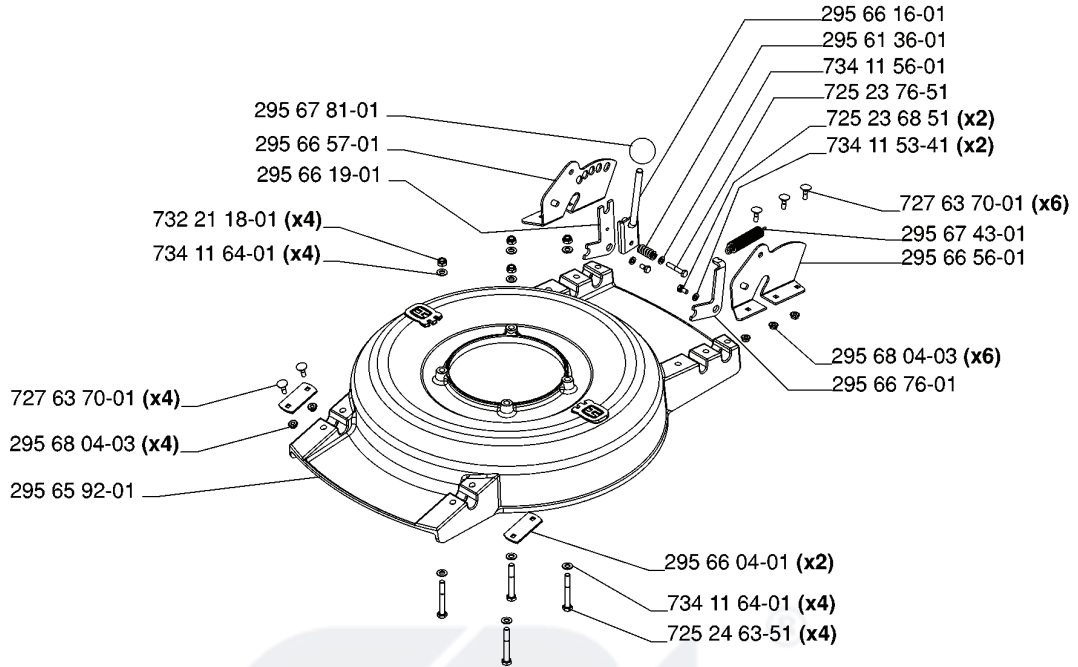

**A M 48**  
**Motor compl 295 68 12-01 (B&S Q 45)**

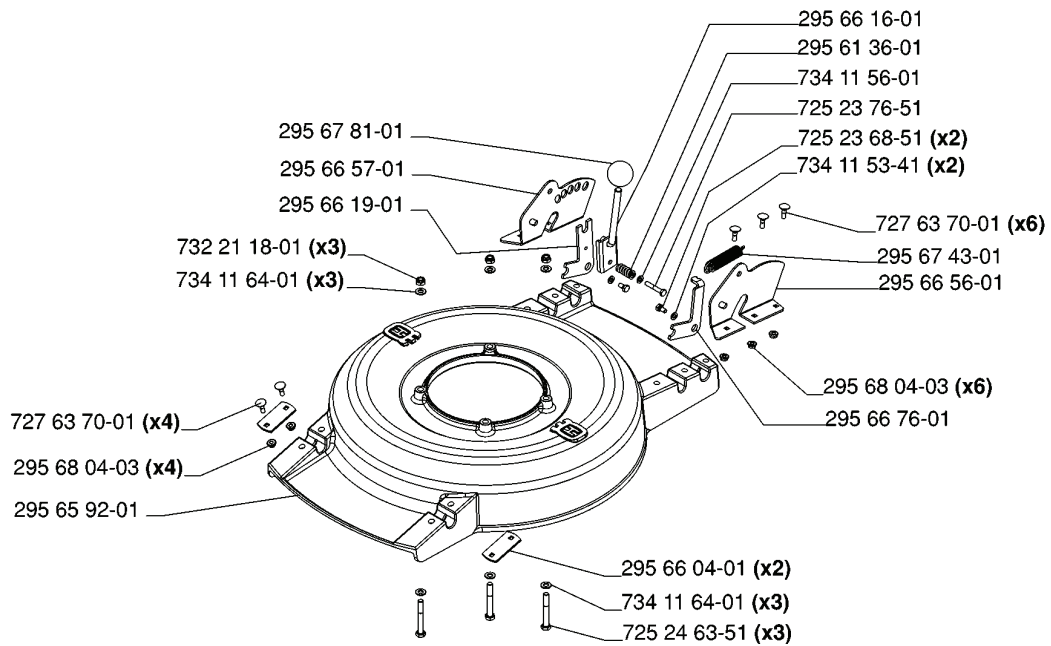

REF.	PART NO.	DESCRIPTION	REMARK	QTY.	KIT
295 68 13-01	295681301	ENGINE		1	
295 67 81-01	295678101	BALL		1	
295 66 57-01	295665701	INDEX PLATE		1	
295 66 19-01	295661901	LINK ARM		1	
732 21 18-01	732211801	LOCK NUT		4	
295 68 04-03	295680403	LOCK NUT		4	
295 66 76-01	295667601	LEVER		1	
295 67 43-01	295674301	SPRING		1	
727 63 70-01	727637001	SCREW RSQM		6	
734 11 53-41	734115341	WASHER		2	
725 23 68 51	725236851	SCREW		2	
725 23 76-51	725237651	SCREW EHHM		1	
295 61 36-01	295613601	SPRING		1	
295 66 16-01	295661601	LEVER ASSY		1	
295 68 12-01	295681201	ENGINE		1	
295 65 92-01	295659201	CHASSIS		1	
725 24 63-51	725246351	SCREW EHHM		3	
734 11 64-01	734116401	WASHER		3	
295 66 04-01	295660401	BRACKET		2	
295 66 56-01	295665601	HANDLE SUPPORT		1	
725 23 68-51	725236851	SCREW		2	
734 11 56-01	734115601	WASHER		1	

**D** M 48 Pro

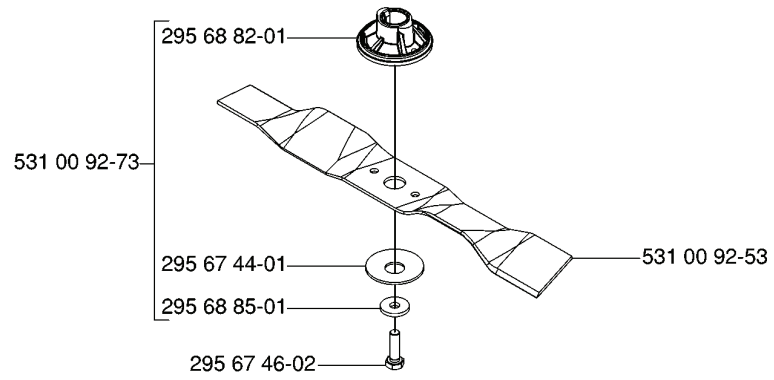

**D** M 48

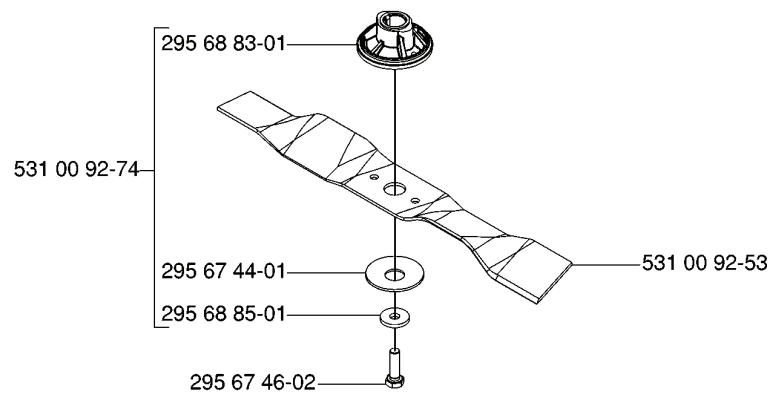

---

REF.	PART NO.	DESCRIPTION	REMARK	QTY.	KIT
295 68 82-01	295688201	BLADE SUPPORT		1	
531 00 92-73	531009273	KNIFE KIT		1	
295 68 83-01	295688301	BLADE SUPPORT		1	
531 00 92-74	531009274	KNIFE KIT		1	
295 67 44-01	295674401	SPRING		1	
295 68 85-01	295688501	WASHER		1	
295 67 46-02	295674602	BOLT		1	
531 00 92-53	531009253	BLADE		1	

GPL®



**B** M 48 Pro

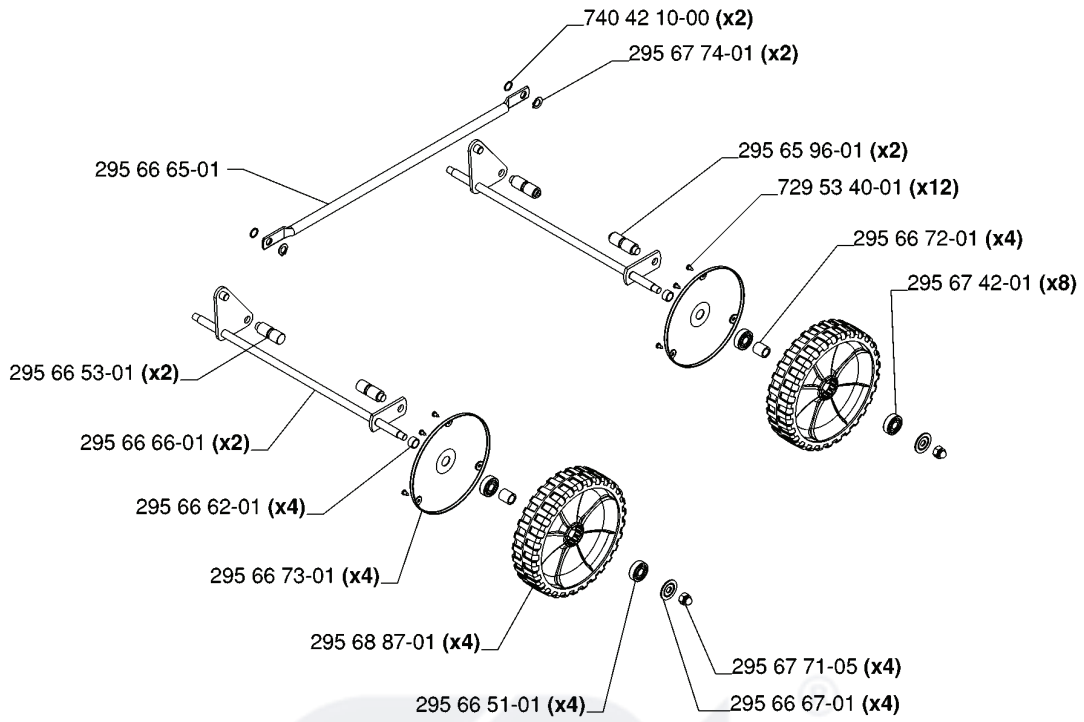

**B** M 48

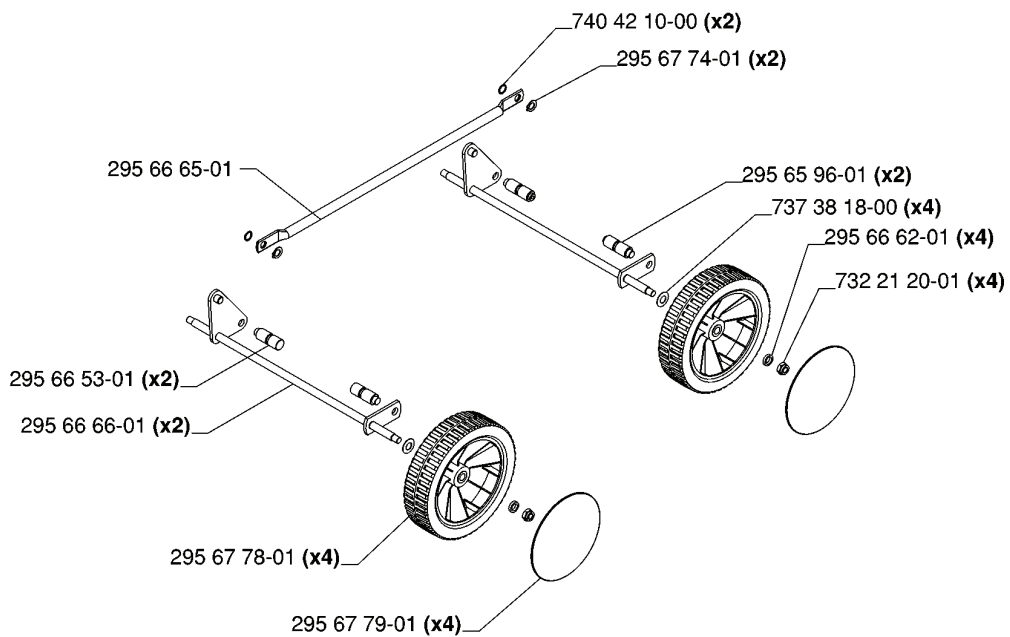

REF.	PART NO.	DESCRIPTION	REMARK	QTY.	KIT
295 66 53-01	295665301	SHAFT		2	
295 66 73-01	295667301	SHIELD		4	
295 68 87-01	295688701	WHEEL ASSY		4	
295 66 51-01	295665101	TIRE		4	
295 66 67-01	295666701	WASHER		4	
295 67 71-05	295677105	NUT		4	
295 67 42-01	295674201	BALL BEARING		8	
295 66 72-01	295667201	SPACER		4	
729 53 40-01	729534001	SCREW CCRPANT		12	
295 65 96-01	295659601	SHAFT		2	
295 66 65-01	295666501	ROD		1	
295 66 66-01	295666601	AXLE		2	
295 67 78-01	295677801	WHEEL		4	
295 67 79-01	295677901	HUB CAP		4	
732 21 20-01	732212001	LOCK NUT		4	
295 66 62-01	295666201	SPACER		4	
737 38 18-00	737381800	CUP		4	
295 67 74-01	295677401	RING		2	
740 42 10-00	740421000	O-RING		2	

